

# MINI-DOZER

## Plans - Assembly Manual

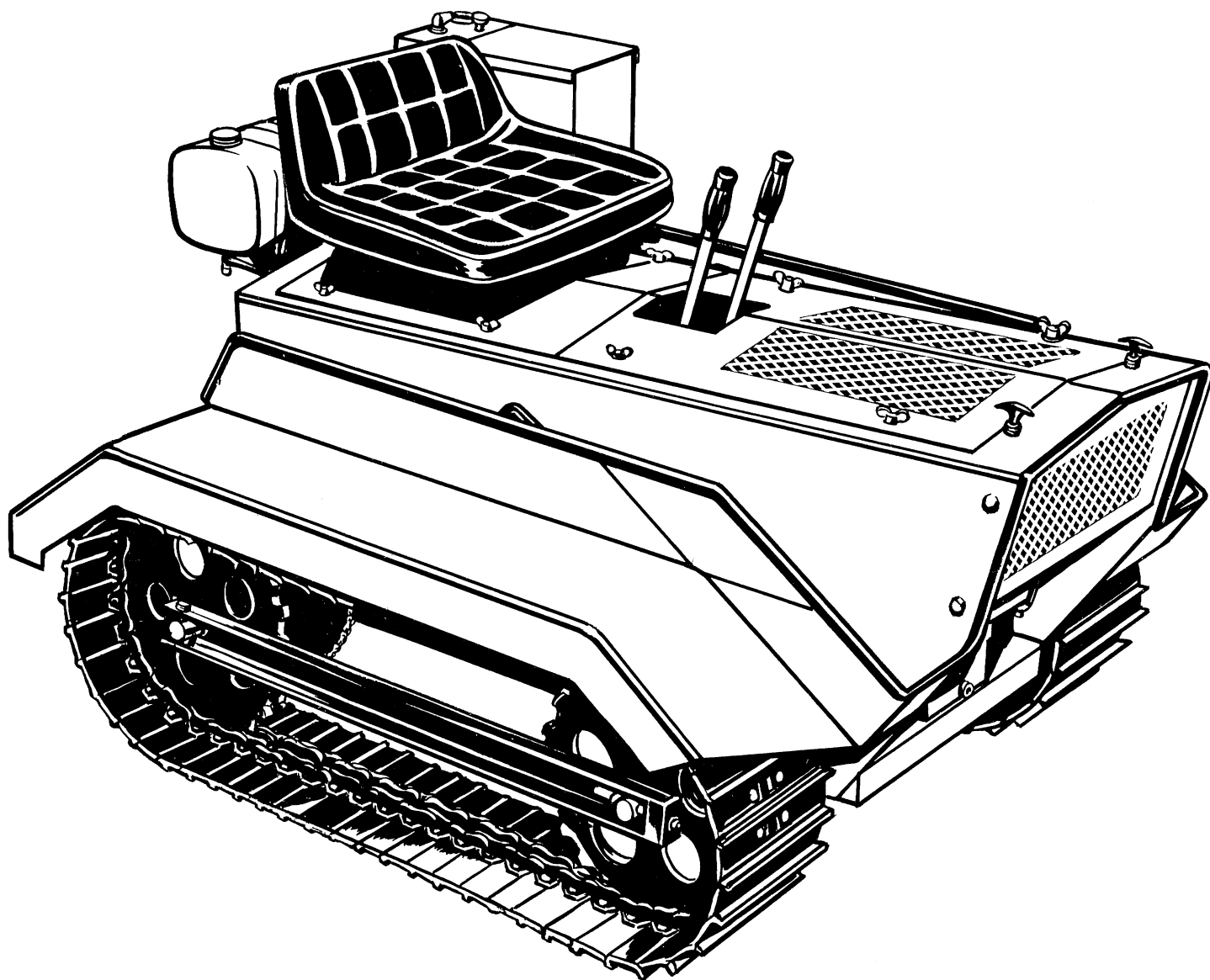

These Plans are sold solely for non-Commercial purposes and their sale in no way licenses any individual or firm to reproduce the Mini-Dozer in any form for resale. To do so will constitute direct violation of all patents applicable at that time.

To reproduce these Plans and Instructions in any form will constitute direct violation of our Copyright.

C. F. STRUCK CORP.

PARTS LIST FOR MD1200 and MD1600 SERIES TRACTORS

MD1200-1 Body

- 1AL Left Body Wall
  - 1AR Right Body Wall
  - 1B Plate (2)
  - 1C Front Brace
  - 1D Rear Brace
  - 1E Mount
  - 1F Plate (4)
  - 1G Pan
  - 1H Segment
  - 1I Bar
  - 1J Brace (2)
  - 1K Handle
  - 1L Rod
  - 1M Baffle (MD1207)
  - 1N Strip (2) (MD1207)
  - 1OR Right Footwell
  - 1OL Left Footwell
  - 1P Plate (2)
  - 1Q Plate (2)
  - 1R Clip
  - 1S Clip
  - 2A Grill (MD1207)  
MD1200-2A Grill  
-2B Screen
  - 2B Grill & Muffler Assembly  
(MD1200, 1612 and 1600)  
2A Grill  
44 Muffler  
MD1600-2A Baffle
  - 3A Hood (MD1207)  
3A Hood  
3B Screen
  - 3B Hood (MD1200, 1612 & 1600)  
MD1200-3A Hood  
MD1600-3A Screen
  - 4 Rear Cover  
4A Cover  
4B Bracket  
4C Clip
  - 5 Tank Mount  
5A Bracket  
5B Gusset
  - 6 Battery Box  
6A Side  
6B End  
6C Mounting Bracket
  - 6D Ammeter
  - 6E Ignition Switch
  - 6F Light Switch (Light Kit only)
  - 6H Battery (12 volt w/acid,  
instructions & Cover for  
Positive Terminal)
  - 6I Wiring Harness  
90° Elbow  
6N Wire (blue) 65"  
6P Wire (yellow) 68"  
6S Wire (heavy black) 67"  
6T Wire (red) 68"
  - 6J Retaining Clips (4) ½" dia.; for #6I Harness
  - 6K Battery (-) Wire 10" (heavy black)  
½" ID loop each end.
  - 6L Battery (+) Wire 7½" (heavy black)  
½" ID loop one end; 3/16" ID loop other end.
  - 6M Wire (red) 4½" w/fuse (Light Kit only)
  - 6O Wire (black) 4"
  - 6U Wire (blue) 8" (Light Kit only)
  - 6V Sealed Beam Light (2) (Light Kit only)
  - 6W Wire (green) 10"
  - 6X Wire (black) 10"
  - 6Y Wire (red) 15½" (MD1207)
  - 6Z Wire (red) 6½" (MD1207)
  - 6AA Solenoid
  - 6VA Tube (Light Kit only)  
Cap Screw 1/4-20 x 3/4 (3)  
Cap Screw 5/16-18 x 3 (2) (Light Kit only)  
Carriage Bolt 5/16-18 x 7 (2)  
Sheet Metal Screws (4)  
Star Washer 5/16 (2) (Light Kit only)  
WI Washer 1/4 (3)  
WI Washer 5/16 (2) (Light Kit only)  
Locknut 1/4-20 (3)  
Locknut 5/16-18 (2) (Light Kit only)  
Wing Nut 5/16-18 (2)  
Electrical Connector 1/2" dia. (1)  
(Light Kit only)  
Electrical Connector 3/8" dia. (1)  
(Light Kit only)
  - 7 Rear Cover (Dash)
  - 8 Front Cover
  - 9 Strip
- NOTE: Parts #6 through #9 apply to electric start engines only
- 10R Bearing
  - 10L Bearing  
10A Plate (4)  
10B Tube (2)  
10C Pull (2)
  - 11 Gusset (2)
  - 12 Axle (2)
  - 13 Track Expander (2)  
13AA Plate (2)  
13B Expander (2)
  - 14 Pivot Rod
  - 15R Right Clutch Control Handle
  - 15L Left Clutch Control Handle  
15A Tube (2)  
15B Handle (2)  
15C Lever (2)  
15D Arm (2)
  - 16 Clutch Belt Guide (4)
  - 17 Engine Belt Guide (2)
  - 18 Light Bracket (2) (Electric Light Kit only)
  - 19 Drawbar
  - 20A Sprocket & Shaft 8 Tooth #40 (2)  
(MD1207 & 1200)  
20A Shaft (2)  
40A8 Sprocket (2)

MD1200-20B Sprocket & Shaft 8 Tooth #50 (2) (MD1612 & 1600)	20B Shaft (2)	50A8 Sprocket (2)	21 Power Shaft (2)	22A Rear Drive Wheel 54 Tooth #40 (2) (MD1207 & 1200)	22A Tube (2)	40A54 Sprocket (2)	22 Tooth Iron Sprocket (2)	22B Rear Drive Wheel 54 Tooth #50 (2) (MD1612 & 1600)	22A Tube (2)	50A54 Sprocket (2)	22 Tooth Iron Sprocket	23 Handle	23A Handle	23B Belt Guide	23C Nut	24R Right Mud Fender	24L Left Mud Fender	24A Fender (2)	24R Brace (2)	24C Gusset (6)	25 Front Idler Wheel (2)	25A Tube (2)	22 Tooth Iron Sprocket (2)	26 Self-Aligning Bearings, w/two stamped mounting "shells" (4)	27 Idler Pulley 4" OD x 3/8 bore	28 Idler Wheel 2" OD x 3/8 bore (4) - (MD1207 & 1200) (6) - (MD1612 & 1600)	29 Pulley 12" OD x 7/8 bore (4) - (MD1207 & 1200) (6) - (MD1612 & 1600)	30A Pulley 5" x 3/4 bore "V" (2) - (MD1207 & 1200) (1) - (MD1612 & 1600)	30B Pulley 5" OD x 3/4 bore "flat" (1) - (MD1612 & 1600)	31 Pulley 3" OD x 3/4 bore (4) - (MD1207 & 1200) (6) - (MD1612 & 1600)	32A Pulley 3" OD x 1 bore (1) - (MD1207 & 1200)	32B Pulley 3.5" OD x 1 bore (1) - (MD1612 & 1600)	33A Main Drive Belt BB68 (1) (MD1207 & 1200)	33B Main Drive Belt B67SC (1) (MD1612 & 1600)	34A Clutch Belt 4L500 (4) (MD1207)	34B Clutch Belt A48SC (4) (MD1200) (6) (MD1612 & 1600)	35 Handgrips (2)	36 Track-Lawn Shoes w/bolts & Chain (2)	37 Track-Dozer Shoes w/bolts & Chain (2) (Kit comes with <u>one</u> complete set of either above style shoe)	38A Roller Chain #40 w/connector link (2)	38B Roller Chain #50 w/connector link (2)	39A Flexible Exhaust Tube 3/4" ID (MD1207)	39B Flexible Exhaust Tube 1" ID (MD1200, 1612 & 1600)	40 Engine w/instruction booklet 7 hp Lawson-Tecumseh Recoil Start (MD1207) 12 hp Lawson-Tecumseh Electric Start (MD1200 & 1612) 16 hp Lawson-Tecumseh Electric Start (MD1600)	41 Spring (tension - 8" long)	42 Throttle Control (long)	43 Choke Control (short)	44 Bulb Muffler (MD1207)	45 Gas Line	46 Steel Seat Pan	47 Brake Assembly	47A Shaft	47B Tube	47C Plate	47D Strip	48 Pin	48 Pin Washer welded to Pin	49 Spring (tension - 3-3/4" long) (2)	50 Spring (compression - 2" long)	51 Switch ("on-off") w/switch plate & Nut (MD1207)	56 Baffle Assembly (MD1200, 1612 & 1600) MD1600-1A Baffle MD1600-1B Wall
Snap Ring 7/8 (4)	Wing Nut 5/16-18 (8)	Cap Screw 3/8-16 x 3 1/2 (2)	Snap Ring 5/8 (3)	Wing Nut 3/8-16 (1)	Cap Screw 3/8-16 x 4 1/2 (2)	WI Washer 1/4 (2)	Carriage Bolt 1/4-20 x 1/2 (8)	Cap Screw 3/8-16 x 5 (2)	WI Washer 3/8 (88)	Carriage Bolt 3/8-16 x 1 (4)	Set Screw 5/16-18 x 5/16 (30)	WI Washer 5/8 (45)	Carriage Bolt 3/8-16 x 2 1/2 (1)	Cotter Pin 1/8 x 1 1/2 (2)	WI Washer 7/8 (110)	Cap Screw 1/4-20 x 1/2 (2)	Gas Line Pinch Clip (2)	WI Washer 5/16 (110)	Cap Screw 5/16-24 x 1 (2) (MD1207)	Retaining Clips 1/2" (3)	Lock Washer 3/8 (14)	Cap Screw 5/16-18 x 3/4 (34)	Key 3/16 x 1 (12)	Lock Washer 5/16 (15)	Cap Screw 5/16-18 x 1 (12)	Key 3/16 x 3/4 (2)	Star Washer 3/8 (1)	Cap Screw 3/8-16 x 3/4 (6)	Key 1/4 x 1 (1)	Allen Wrench 3/32 (1)	Nut 3/8-16 (10)	Cap Screw 3/8-16 x 1 (11)	Allen Wrench 5/32	Locknut 5/16-18 (36)	Cap Screw 3/8-16 x 1 1/2 (5)	Collar 7/8" (2)	Locknut 1/4-20 (10)	Cap Screw 3/8-16 x 1-3/4 (1)	Hose Clamps (2)	Locknut 3/8-16 (18)	Cap Screw 3/8-16 x 3 (2)																				

MINI-DOZER ASSEMBLY  
(MD1200 & MD1600 Series)

Unpacking the Kit:

Care must be exercised in unpacking the Kit to avoid bending or scratching the various components. As the parts are unpacked, lay them out neatly and check the parts against the enclosed Parts List. Notify us immediately of any shortages.

Setting up for Assembly:

It is best to set the Body in an upright position on the edges of two saw-horses or on top of a crate. This will allow you to easily work around and underneath the Tractor. NOTE: The directions 'Left & Right' and 'Upper & Lower' referred to in the following instructions are determined by standing behind the Dozer and looking forward. 'Inside' refers to the side of a part which is closest to an imaginary center line running down the length of the Dozer. 'Outside' refers to the side farthest from the above defined center line. (Remove Engine from Body and save bolts.)

Lubrication:

Lubricate the "Zerk" fittings on #22 Drive Wheels, #25 Idler Wheels and #10 Bearings as you proceed with their respective assembly. All other bearings are sealed and "life-time" lubricated.

NOTE:

1. To standardize the manufacture and servicing of our line of Mini-Dozers, we've kept components as interchangeable as possible between the two model series (MD1200 & MD1600). To clarify your understanding, please note that MD1200 series tractors cover models MD1207 & MD1200; and that MD1600 series tractors cover models MD1612 & MD1600.

2. As you proceed through the various assembly steps, note that each step refers to all model Mini-Dozers unless a specific model is noted within the step.

3. It is recommended that a Liquid Lock Sealant be applied to ALL set screws, cap screws, nuts and anywhere else that is felt necessary to keep all stationary tractor parts snug and secure. (NOTE: DO NOT put on #20 Sprocket and Shaft)

Assembly:

1. Slide one #12 Axle through 7/8" holes in rear of Body. Slide #22 Rear Drive Wheel on each end of Axle and then follow with two 7/8 WI Washers over each Rear Axle end (large sprocket to outside).
2. Slide second #12 Axle through forward slots in Body. On each Axle end, slide on approximately ten 7/8 WI Washers followed by #25 Front Idler Wheel (sprocket to outside) and finally two more 7/8 WI Washers over each end of Front Axle.
3. Slide #13 Track Expanders over ends of Front and Rear Axles as per assembly drawing (slotted end of Expander is forward). Slide 7/8 WI Washer over each end of four Axle ends and secure with 7/8 Snap Rings. (NOTE: 7/8 WI Washers may be added or removed to give best possible final fit and alignment. Check alignment of each sprocket with straightedge. Take 3/8-16 x 4-1/2 Cap Screw and slide on 3/8 WI Washer. Slide Cap Screw through hole in front end of each Expander and through hole in Front Axle.

Do this to both Right & Left Track Expanders. On ends of each Cap Screw, loosely apply two (2) 3/8 Nuts with 3/8 Lock Washer between. Insert 3/8-16 x 3" Cap Screw into a 3/8 WI Washer and then through the two holes in rear of each Expander (you may have to rotate Rear Axle so Cap Screw will pass through) and secure with 3/8 WI Washer and 3/8-16 Locknut. NOTE: Do not over-tighten this Cap Screw and crush the Expander.

4. Take 3/8-16 x 1 Cap Screw and insert into one "looped" end of #41 Spring. Insert this Cap Screw Assembly into the 3/8" hole in lower outside rear of #1B Plate (right "inside" of Body) and secure inside with 3/8-16 Locknut (see drawing for correct positioning). NOTE: Insert Cap Screw so that Spring's "looped" end can lay "flat" against #1B Plate. In a similar manner, attach the other "looped" end of #41 Spring to the top inside of #1I Bar and secure with 3/8-16 Locknut. NOTE: In both cases, leave The Cap Screws sufficiently loose to allow the Spring moderate swiveling action.

5. Attach #19 Drawbar under #1G Rear Pan with two 3/8-16 x 3/4 Cap Screws and secure inside #1G Pan with 3/8 WI Washers and 3/8-16 Locknuts.

6. Take Gas Tank and Mounting Bracket Assembly and mount onto #5 Tank Mount - note how the four holes and slots line-up with each other. Insert each of four 5/16-18 x 3/4 Cap Screws into 5/16 WI Washers and then into the (above) aligned slots and holes. Secure each Cap Screw on other side with 5/16 WI Washer and 5/16-18 Locknut.

7. Mount the (above) Gas Tank Assembly to the top rear of Tractor Body aligning the two 5/16" holes in #1D Brace and two 5/16" holes in the #1G Pan with the four remaining slots in #5 Tank Mount. Insert each of four 5/16-18 x 3/4 Cap Screws into 5/16 WI Washer and from outside, insert into the four slots of #5 Mount. Secure these Screws inside Body with 5/16 WI Washers and 5/16-18 Locknuts.

8. Mount #10 Bearings (with 10R on right side and 10L on left side and with 10C Pull pointing up) between #1B Plate and their respective #1AL or 1AR Left or Right inside body wall, being sure #10C Pull protrudes up through 1/2" hole in top rear of #1AR and 1AL Wall. Loosely secure 3/8 WI Washer and 3/8-16 Locknut to protruding #10C Pull. NOTE: Holes in #10 Bearing must line up with slots in its respective #1B Plate and #1AL or 1AR Wall. Using 5/16 WI Washers over 5/16-18 x 3/4 Cap Screws, insert into slots of #1B Plate and #1AL or 1AR Wall. Loosely secure inside with 5/16 WI Washers and 5/16-18 Locknuts.

NOTE: Check that above Cap Screws on #1B Plate and #1AL or 1AR Wall point toward each other on each side and that Locknuts are against #10 Bearings in each case.

9. Slide three 7/8 WI Washers onto the end of each #20 Sprocket and Shaft. From outside the Body, insert each Shaft into the Oilite Bushings in #10 Bearings. Take a straightedge and align the faces of the 54 tooth Sprocket on the #22 Drive Wheel with the 8 tooth Sprocket on the #20 Sprocket & Shaft. This alignment can be accomplished by adding more or removing 7/8 WI Washers from the #20 Shaft.

10. On each side of Tractor body, wrap a length of #38 Roller Chain around 8 tooth Sprocket, on #20 Shaft and around 54 tooth Sprocket of #22 Drive Wheel - secure with Connector Link. Draw up on each #10 Bearing Assembly and secure by now tightening the six (6) 5/16-18 Locknuts on each #10 Bearing.

NOTE: Tighten 3/8-16 Lock Nut on #10C Pull just enough to hold #10 Bearing in place, but do not over-tighten and draw #10 Bearing up any further as it will cause #38 Chain to be over-tightened and result in premature wear of chain. (The #10C Pull is just used to keep the #10 Bearing in place when Dozer is working under extreme loads.)

11. Installation of Chain Guards: At this time, if you have chain guards, you may layout and drill the mounting holes per drawing. Take four 5/16-18 x 3/4 Cap Screws and insert into chain guard and then into holes just drilled. Inside 1A Wall, secure with 5/16 WI Washer and 5/16-18 Locknut. Do this for both sides.

12. Inside Body, slide ten 7/8 WI Washers over each protruding end of #20 Sprocket and Shaft. Insert 3/16 sq. x 3/4 Key into each Keyway and slide one #29 Pulley over each Shaft end engaging the 3/16 sq. Key completely in hub of #29 Pulley. Tighten both set screws in each #29 Pulley. Slide five more 7/8 WI Washers over each end of #20 Shafts followed by a 3/16 sq. x 1 Key and second #29 Pulley on each side - tighten all set screws. (On models MD1612 and MD1600: slide five (5) more 7/8 WI Washers over each end of #20 Shafts followed by a 3/16 sq. x 1 Key and a third #29 Pulley on each side - tighten all set screws.) Slip on 7/8 WI Washers necessary to fill out each end of #20 Shaft up to each 1/8" hole - secure with 1/8 x 1-1/2 Cotter Pin. NOTE: Hubs of #29 Pulleys above should all point toward center of Tractor - see drawings.

13. Insert 3/8-16 x 1-3/4 Cap Screw into 3/8 Star Washer and 3/8 WI Washer; then from inside, slip Cap Screw into 3/8" slot in #1H Segment. On the other side of #1H Segment (side closest Left Body Wall), you may slip on seven 3/8 WI Washers followed by #27 Idler Pulley. (At this time, loop the #33 Main Drive Belt over #27 Idler Pulley.) Secure this Pulley Assembly by inserting protruding end of Cap Screw into nut welded to #23 Handle. Check your assembly against drawing; make sure "handle" portion of #23 Handle is pointing toward center of Tractor Body and that #33 Belt is held between the groove of #27 Pulley and the 1/4" round rod welded to #23 Handle Assembly. Tighten Cap Screw so it will still be able to slide freely in 3/8" slot in #1H.

14. Assemble the #30 and 31 Pulleys onto their respective #21 Upper and Lower Shafts.

NOTE:

A. On models MD1200 & MD1207, the #30 Pulleys are both of the "v" type; on models MD1612 & MD1600, the upper #30 Pulley is "v" type while the lower #30 Pulley is the "flat" type.

B. On models MD1200 & MD1207, two #31 Pulleys are on the Upper Shaft, two are on the Lower Shaft; on models MD1612 & MD1600 four #31 Pulleys are on the Upper Shaft, two are on the Lower Shaft.

C. Note that hub of #30 Pulleys point inward on both Upper and Lower #21 Power Shafts; also the hubs of the #31 Pulleys point toward each other on the Lower Shaft, but away from each other on the Upper Shaft.

15. Assemble #26 Self-aligning Bearings by placing a spherical bearing unit between two stamped mounting halves - loosen all Bearing set screws with Allen Wrench provided. Mount two of these assemblies in the 1-3/4" holes on inside of left #1AL Body Wall with 1/4-20 x 1/2 Carriage Bolts provided. Loosely apply 1/4-20 Locknuts to above Bolts which should protrude out left side of Body. NOTE: Bearing's hubs (with set screws) should be to the outside.

16. From inside Body, insert the "right" ends of #21 Upper and Lower Power Shafts a few inches into their respective 1-3/4" dia. holes on right #1AR Body Wall. (NOTE: On models MD1200 & MD1207, loop two #34 "v" Belts on both the Upper and Lower #21 Shafts; on models MD1612 and MD1600, loop four #34 "v" Belts over Upper Shaft and two #34 Belts over Lower Shaft.) Check that Lower #21 Power Shaft does not go through #33 Belt; and that Upper #21 Power Shaft does go through #33 Belt. (NOTE: CHECK "BELT DIAGRAMS" FOR PROPER BELT WRAPPING.)

17. Slide both the #21 Upper and #21 Lower Power Shafts to the left and engage 5/8" "stepped" ends of Shafts into their respective 5/8" dia. "bore" of the previously installed #26 Bearings. Push Shafts fully to the left until Shafts "stepped shoulder" hits bearing.

18. From outside Right #1AR Body Wall, note the two remaining ends of #21 Upper and Lower Shafts protruding through their respective 1-3/4" Bearing holes. Take the two remaining #26 Self-aligning Bearings (assembled in Step #15) and with hub of Bearing pointing outward, engage the 5/8" dia. bore of Bearings onto "stepped" ends of #21 Shafts and slide Bearings tight against the outside of #1AR Body Wall. Note the gap between shoulder of #21 Shafts and the "face" of their respective #26 Bearing. Determine how many 5/8 WI Washers are necessary to "shim" this gap - then remove both Bearings, add shim Washers (equal number of Washers on ends of each Shaft) and re-mount Bearings on Shafts. Check for proper shimming (do not "force-in" extra washers) and then from outside Body, insert four remaining 1/4-20 x 1/2 Carriage Bolts into Bearing housings and secure inside Body with 1/4-20 Locknuts. Tighten set screws in both #26 Bearings and also tighten 1/4-20 Locknuts holding Bearings.

19. Lock all #26 Bearing Set Screws and check for smooth rotation of #21 Shafts - remove some 5/8 WI Washers if you've found they "wedge or bind" Bearings' free rotation. Insert 3/16 sq. x 1 Keys in each Pulley hub engaging the 3/16 slot in their respective #21 Upper or Lower Power Shaft.

20. Align the two 5" dia. #30 Pulleys with the previously mounted #27 Idler Pulley so they all have a common vertical center line and this "center line" is parallel with the inside of #1AL Body Wall; then tighten set screws in #30 Pulleys. Next align the #31 Pulleys with their mating #29 Pulleys mounted on #20 Shafts. (Note Drawings to check that #31 Pulleys on Upper #21 Shaft align with mating #29 Pulleys mounted to the outside on #20 Shafts. Also check that the #31 Pulleys on Lower #21 Shaft align with mating #29 Pulleys mounted to the inside on #20 Shafts.) Tighten all set screws. Slip #34 Belts around mating Pulleys per above alignment instructions.

21. Assemble #15R and 15L Clutches at this time - check Drawings to note difference between #15R and #15L.

A. On models MD1200 & MD1207: Using 3/8-16 x 3-1/4 Cap Screw with 3/8 WI Washer over one end, slide into #16 Belt Guide. Follow with three 3/8 WI Washers, slide into #28 Idler Wheel and follow with four more 3/8 Washers. Now slide into slot in arm of #15R Right Clutch. On other side, slip on four more 3/8 Washers, #28 Idler Wheel, three 3/8 Washers, #16 Belt Guide, 3/8 WI Washer and secure with 3/8-16 Locknut.

B. On models MD1612 & MD1600: Using 3/8-16 x 5 Cap Screw with 3/8 WI Washer over one end, slide into #16 Belt Guide. Follow with three 3/8 WI Washers, slide into #28 Idler Wheel and follow with four more 3/8 Washers. Now, slide into "outside" of slot in arm of #15R Right Clutch. On other side, slip on four more 3/8 WI Washers, #28 Idler Wheel, eleven more 3/8 WI Washers, and third #28 Idler Wheel. Slip on three more 3/8 WI Washers, #16 Belt Guide, 3/8 WI Washer and secure with 3/8-16 Locknut. (Check assembly Drawings at this time to make sure you have the various parts assembled in the proper order and that the #16 Belt Guides - specifically the "90° hooked ends" - are facing the proper direction.) Align the #16 Guides so they make approximately a 90° angle with the slotted arm of the #15R Clutch and then loosely tighten 3/8-16 Locknut.

22. Repeat previous step, but this time assembling #15L Left Clutch. Using 3/8-16 x 1 Cap Screws, attach one end of each #49 Spring to the outside of its respective #15D Arm - secure with 3/8-16 Locknut but leave sufficiently loose so the Spring may rotate freely on Cap Screw. (Note: Insert Cap Screw so that Spring's "looped" end can lay "flat" against #15D Arm.)

23. Insert above #15R and 15L Clutch Assemblies into respective locations inside Body. From outside Body, slide #14 Pivot Rod through Body Wall, then through tube on each Clutch, and finally through other Body Wall. (CHECK "BELT DIAGRAMS" FOR PROPER #34 BELT WRAPPING OVER #28 IDLERS.) Note that Clutch Assemblies have freedom to slide left and right on the #14 Pivot. At this time by sliding Clutches left and right, align the #28 Idler Wheels with their respective #29 Pulleys mounted on #20 Shafts. Remove #14 Pivot Rod and attach remaining ends of #49 Springs to their respective "inside" position of #1S Clip using 3/8-16 x 1 Cap Screws and Locknuts similarly as in Step #22. (Again, check that all ends of #49 Springs can rotate freely!) Reinsert #14 Pivot Rod into #15R and 15L Clutch Assemblies; this time using 5/8 WI Washers as shims along #14 Rod to hold the Clutch alignment determined above. From outside of 1AR and 1AL Body Wall secure #14 Pivot Rod with 5/8 Snap Rings.

24. Now you must properly adjust #28 Idler Wheel assemblies you assembled above. Slide Wheel assemblies rearward (or forward as the case may be) so that the Clutch Control Handles can move forward and backward a total distance of approximately 4" as measured at the "handgrip" ends of #15 Control Handles. Make this travel equal in both Control Handles and then tighten each 3/8-16 x 3-1/4 Cap Screw (3/8-16 x 5 Cap Screw on MD1612 & MD1600). (Check for proper 90° angle of #16 Guides as explained in Clutch Assembly Step above.) NOTE: Check to make sure that all four #16 Guides ride with their "90° hooked end" to the outside of their #34 Belt. In proper operation, as a #28 Idler Wheel moves away from tightening a #34 Belt, simultaneously the "90° hooked end" of its respective #16 Guide should start to hit the backside of the #34 Belt and start to pull it "in" to eliminate any excessive slack and release its grip on #31 Pulley.

25. Take Engine and slide on "hub first" #32 Pulley onto Engine's Crankshaft. Slide 1/4 sq. x 1 Key into Pulley's hub.

A. On 7 hp Engine: Install the two #17 Belt Guides using a 5/16 Lock Washer and 5/16 WI Washer over ends of two 5/16-24 x 1 Cap Screws which are each inserted into "loop end" of #17 Belt Guides. Follow with second 5/16 WI Washer on each and then screw each Guide Assembly into the two rear 5/16-24 threaded holes in Engine Case - see "7 hp Engine - PTO View" Drawing for proper assembly; note that "90° hooked ends" of #17 Belt Guides point away from Engine Case.

B. On 12 and 16 hp Engine: Take #56 Baffle and align its two 3/8 holes over the top two 3/8-16 threaded holes in the engine's face. Insert 3/8-16 x 1-1/4 Cap Screw into a 3/8 Lock Washer followed by a 3/8 WI Washer. Insert into "loop" of one #17 Belt Guide (90° "hooked" end pointing away from engine) and then into rear 3/8 hole of #56 Baffle engaging Screw in (above) aligned threaded hole in engine face. Insert 3/8-16 x 3/4 Cap Screw in a 3/8 Lock Washer and then a 3/8 WI Washer; insert into remaining forward 3/8 hole in Baffle and engage threads in engine face - Tighten.

Insert 3/8-16 x 1 Cap Screw into 3/8 Lock Washer, 3/8 WI Washer, and then into "loop" of second #17 Belt Guide. Screw this assembly into lower rear 3/8-16 threaded hole in engine's face - keep 90° "hooked" end pointing away from engine. (NOTE: Check Engine Assembly MD1200, MD1612 & MD1600 drawing for proper assembly of this step.)

26. Install Engine in Engine Compartment of Tractor keeping the Crankshaft on left side.

A. Mount 7 hp Engine to Body's #1E Mount with four 5/16-18 x 1 Cap Screws and 5/16 WI Washers coming up from underside of #1E Mount and engaging four holes in mounting plate of Engine. Secure above with 5/16 WI Washers and 5/16-18 Locknuts.



B. Mount 12 & 16 hp Engine with 3/8-16 x 1 Cap Screws and Lock Washers coming up from underside of #1E Mount and engaging the 3/8-16 threads in bottom of engine. In both cases above square Engine in Body (Crankshaft should be at approximately a 90° angle with the inside of the left #1AL Body Wall) and then tighten the four Cap Screws. At this point, loop the #33 Drive Belt around the #32 Pulley.

27. Slide #2 Grill into front of Body and align the four 3/8" holes. Insert 3/8-16 x 1-1/4 Cap Screw into 3/8 WI Washer and then from outside body, insert cap screw into each of the four 3/8" holes. On the inside, secure with 3/8 WI Washer and 3/8-16 Locknut. NOTE: If you have the light kit, install the #18 Light Brackets on the outside of Body Walls using the above assembly. (Check Drawing).

28. Insert #42 Throttle Control into the 9/16" hole on the left of #1C Brace. Secure below with Lock Washer and Nut provided. Using the "Throttle Control Wire" Drawing for your particular Engine Horsepower, slide the wire "casing" into its respective Bowden Wire Clamp at the Throttle on Engine. Engage the offset end of Bowden's "inner Wire" into the 1/16" hole in your particular Engine Throttle lever. With #42 Throttle Control Handle pushed all the way in, the Throttle Lever should be pushed to the slow (idle position) so that the throttle on the carburetor is closed and resting against the idle adjustment screw. Now, tighten the Bowden Wire Clamp.

29. On 7 hp Engine (only): Attach the 3/16 ID loop ends of #6Z and 6Y Wires to #51 (on-off) Switch. (Note wire positions in Drawing) from inside Tractor Body, insert Switch into left front 1/2" hole followed by "on-off" switch plate. Turn Switch so "on" is forward and secure with nut provided. Check Step #28: Pulling up on Handle of #42 Control should open the Throttle Lever to the "fast" position. (NOTE: To hold a particular Throttle setting, give the control a 1/4 turn to lock in place).

30. Insert the shorter #43 Choke Control into the remaining 9/16" hole on right of #1C Brace. Secure below with Nut and Lock Washer. Run Control "casing" rearward and loop around inside #1M Baffle and insert into Bowden Wire Clamp mounted to clip bolted to Engine's housing. Engage "offset end" of Bowden's Inner Wire into hole on Engine Choke Lever above carburetor. (NOTE: Do not use hole in middle of "arrow" on Choke Lever.) With #43 Choke Control pushed in, the Choke Lever should rotate toward the Air Cleaner and stop. At this point, tighten the Bowden Wire Clamp. Check Choke Control, pulling out #43 Control Handle should rotate Choke Lever so that it stops at a point perpendicular to the engine Crankshaft.

31. On 7 hp Engine only: Pull up on Engine Starter Rope and tie a "loop knot" to keep it from retracting. Remove Handle from rope and inset rope through 3/8" grommet above recoil starter. Reassemble Handle on rope end and remove knot to allow rope to recoil. Insert "plug" end of #6Y Wire onto "spade" terminal mounted to Engine frame located beneath gas tank.

32 A. Exhaust 7 hp Engine: Following "Engine Assembly" - MD1207 drawing, screw 3/4 x 1" Reducer Nipple onto 1" pipe Nipple welded to #1E Mount. In 3/4" end of Reducer, screw in 3/4" Pipe Nipple - tighten both. Take 3/4" inside diameter #39 Flexible Exhaust Tube and insert over the 3/4" Nipple on Reducer; take other end of #39 Tube and slip over the 3/4" Pipe Nipple screwed into 45° Street Elbow on Engine. Screw #44 Bulb Muffler onto end of 1" Pipe Nipple (protruding below bottom of #1E Mount) as tightly as possible.

B. Exhaust 12 & 16 hp Engine: Following "Engine Assembly" - MD1200, MD1612 and MD1600 drawing, take 1" inside diameter #39 Flexible Exhaust Tube and insert over the 1" Pipe Nipple coming from engine's exhaust; take other end of #39 Tube and slip over the 1" Street Elbow coming from muffler assembly welded to #2 Grill Assembly.

NOTE: It will help if before installation you grip one end of the #39 Tube with your left hand and the other end with your right; then viewing either end of the Tube, twist it clockwise. This will increase its inside diameter and make it slip easily over its respective Pipe Nipples. After installation, twist the Tube ends counter-clockwise and they will grip the Nipples firmly. Secure both ends of Tube with Hose Clamps provided.

33. On electric start tractors, place #6 Battery Box in rear of Left #10L Footwell. Align the holes and slot in #6C Brace on bottom of #6 Box with the 5/16" holes in #10L Footwell and #1AL Body Wall. Insert each of two 5/16-18 x 3/4 Cap Screws into 5/16 Lock Washer and then into 5/16 WI Washer. Take these Screws and insert them into the two holes in #6C Brace and pass through the "aligned" 5/16" holes in #1AL Body Wall. Secure these Screws inside Body by engaging them into the two 5/16-18 threaded holes in #11 Gusset - Tighten. (Check Drawing - make sure 7/8" hole in #11 Gusset is visible at end of 7/8" slot in #1AL Wall.)

34. If you do not have electric starting, just assemble #11 Gusset as per above, but eliminate reference to #6 Battery Box. On right rear top side of Body, mount second #11 Gusset using same "Cap Screw" procedure as in Step #33. NOTE: This "right side" #11 Gusset must be removed and its 7/8" hole slid onto lift handle of #BH-100 Rear Hitch or ML-40 Lift Mechanism when these attachments are used. After being slid onto its respective "lift handle", the #11 Gusset must be reinstalled on #1AR Body Wall - bolted to the inside of Wall for #BH-100 Hitch; bolted to outside of #1AR Wall for ML-40 Lift.

### 35. Assembly for Electric Start and Lights:

NOTE: Before assembly, read these instructions thoroughly as improper assembly may lead to damage of the electrical system.

A. Mount #6E Switch into 5/8" hole in left rear of #7 Cover. Mount from below Cover and keep lock washer behind Cover and on top - secure with Nut. (See Wiring Diagram for proper location of terminals.) Using 1/4-20 x 1/2 Cap Screws, WI Washers and Lock nuts, install #6AA Solenoid to the lower inside rear wall of #6 Battery Box - keep dimpled end upward. (NOTE: Keep heads of Cap Screws inside Box with Cap Screw ends protruding out of Box.)

B. Mount #6F Switch in 3/8" hole in center front of #7 Cover. Mount from below, keep nuts one on either side of #7 Cover and try to keep threaded portion of Switch from protruding above nut on top of Cover. (See Wiring Diagram for proper location of terminals.)

C. Mount #6D Ammeter from top of #7 Cover into 2-1/8 hole in rear left of #7 Cover. Secure (behind Cover) by slipping the "yoke" assembly over two screw ends protruding from rear of Ammeter. Screw securely one nut over each screw end. (NOTE: Check that plastic insulators are properly installed in "Yoke" assembly and that the (above) two nuts touch only these insulators and do not make metal to metal contact with any portion of the "Yoke".)

D. Take end of #6I Wiring Harness extending from bottom of #6 Battery Box and run loosely along top inside of left #1AL Body Wall keeping harness behind and going past #1M Baffle to Engine Starting Motor.

E. It is advisable at this time to wrap electrical tape along the complete length of #6I Wiring Harness to make it neat looking and to give it added abrasion resistance.

F. Take (heavy black) #6S Wire (in #6I Wiring Harness) and connect its 1/4" ID loop to 1/4-20 terminal on starting motor of engine - Tighten. Connect 5/16" ID loop end of #6S Wire to the (left side) of the 5/16-18 terminal on #6AA Solenoid - Tighten.

G. Connect the two prong Square female plug of #6I Wiring Harness with the mating male plug found protruding alongside Starter on engine. NOTE: The #6T red wire and the red wire from the engine should align with each other in the plug. Connect the five prong black female plug on the other end of #6I Wiring Harness to the five prongs protruding from the bottom of #6E Switch.

H. Slip the loop of the (red) #6T Wire of #6I Harness over protruding screw on (+) side of #6D Ammeter. Follow with a 3/16" ID loop from (red) #6M Wire over same "protruding screw" above and secure with Lock Washer and Nut provided with Ammeter. Connect remaining end of (red) #6M Wire to one terminal of #6F Switch. Connect one 3/16" ID loop end of (black) #6O Wire to (-) "protruding screw" on #6D Ammeter and secure with Lock Washer and Nut. (NOTE: The (+) and (-) screws are determined by looking at the (+) and (-) marks on the face of #6D Ammeter and selecting the corresponding screw below.)

I. Slip 5/16 WI Washer onto end of 5/16-18 x 3 Cap Screw and insert into one side of "looped bracket" on #6V Light, then into 6VA Tube. Insert Cap Screw end of this assembly into a 5/16 Star Washer and then into the 3/8" hole on top outside of #18 Bracket. Secure on other side with 5/16-18 Locknut. (Do this for both lights.) Clean 1/2" insulation from wire coming out bottom of #6V Lights and insert wires into gap between underside of #1G Brace and top of #2 Grill.

J. Connect 3/16" ID loop end of (blue) #6N Wire to remaining terminal of #6F Switch. Clean 1/2" of insulation from each end of (blue) #6U Wire and from remaining end of (blue) #6N Wire. Wind together the wire ends of #6V Light (left Light only), the remaining end of (blue) #6N Wire and one end of (blue) #6U Wire to form a "pigtail". Slip the 1/2" dia. Electrical Connector over the above "pigtail" and screw it on tightly making sure none of the "pigtail's" wires are exposed. Similarly, connect remaining end of (blue) #6U Wire to wire from #6V Light on right side and screw on 3/8" dia. Electrical Connector.

K. Take 5/16 ID loop ends of #6W (green) and #6L (heavy black) wires and slip onto 5/16-18 terminal (right side) of #6AA Solenoid - Tighten. Connect #6X (black) wire from #6E Switch to "center" (forward) 3/16 terminal of #6AA Solenoid and secure. Insert 1/4-20 x 3/4 Cap Screw into upper 1/4" hole in #6 Box. Take 1/4" ID loop of (heavy black) #6K Wire and slip onto the 1/4-20 x 3/4 Cap Screw inside box and secure with 1/4-20 Lock nut. (NOTE: Scrape some paint off around the 1/4" hole in #6 Box so that the 1/4-20 x 3/4 Cap Screw makes "metal to metal" contact with the Battery Box.)

L. Fill #6H Battery with acid per the enclosed instructions. Insert Battery into #6 Battery Box (+ & - terminals on right side of Box) and secure with #9 Strip held to top of Battery by two 5/16-18 x 7 Carriage bolts which pass through the bottom of Box and are secured outside and below box with 5/16-18 Wing Nuts.

M. Insert 1/4-20 x 3/4 Cap Screw into 1/4" ID loop of (heavy black) #6L Wire and insert this into (+) terminal of #6H Battery - secure with 1/4 WI Washer and 1/4-20 Locknut. Mount plastic Terminal Cover over the (+) terminal of Battery - note how #6L Wire fits into slot provided for it in the narrow end of Terminal Cover. Insert 1/4-20 x 3/4 Cap Screw into remaining 1/4" ID loop of #6K Wire and insert Screw into (-) terminal of #6H Battery - secure with 1/4 WI Washer and 1/4-20 Locknut. (NOTE: For Tractors without Light Kit, fill 3/8 Hole in #7 Cover with 3/8-16 x 3/4 Cap Screw and Locknut. Also apply electrical tape to ends of the unused (blue) #6N Wire.)

N. Your wiring is now complete - use this opportunity to completely go over the above assembly instructions and check for any wiring mistakes. (NOTE: To improperly wire your Tractor will run the risk of almost immediate "burnout" of Alternator, Regulator-Rectifier, etc.) Charge Battery at this time using standard 12 volt Charger. Mount #8 Front Cover over "front" of #6 Box and secure on each side with two of the sheet metal screws provided.

O. Carefully bring #7 Cover down onto #6 Box and with two Sheet Metal Screws secure each side of #7 Cover to sides of #6 Box. (NOTE: To avoid any possible shorting from wires inadvertently touching each other or the Box, it is advisable to take electrical tape and cover all exposed terminals on Ammeter and Switches.)

36. Slip four plastic coated #6J Retaining Clips over the #6I Wiring Harness at the four locations of 5/16-18 Weldnuts welded to underside of Left #1AL Body Wall. Note that the Clips are installed so that their flat side (slot side) will lie flat against the underside of the Weldnut, and their "coated clip" portion will lie to the right of the Weldnut. On each of four 5/16-18 x 1 Cap Screws, slip on one 5/16 Lock Washer followed by three 5/16 WI Washers. From inside Tractor Body, insert each of these Cap Screw Assemblies into underside of each of the above Retaining Clips and engage threads of 5/16-18 Weldnuts. Smooth out the #6I Wiring Harness held by these Clips and form a smooth path from #6 Battery Box to the engine. (Make Radius around corners smooth and sweeping - do not kink Wiring Harness.) Tighten the (above) four Cap Screws and notice that you now have the tips of the Cap Screws protruding out the top of #1AL Wall at four locations. (NOTE: For tractors without electric starting Engines, omit above Step and insert the following; slip one 5/16 Lock Washer followed by four 5/16 WI Washers over each end of four 5/16-18 x 1 Cap Screws. Screw these Cap Screws into the "bottom" of each of the 5/16-18 Weldnuts welded to underside of Left #1AL Body Wall and tighten. NOTE: Insert left front 5/16-18 x 1 Cap Screw into 5/16 ID loop terminal of #6Z Wire before inserting into its respective Weldnut - Tighten.

37. Take #45 Gas Line and slip a Pinch Clip over each end and slide up about 1". Slip one end of the Gas Line over the "tapered stepped" outlet on "pet cock" on underside of Gas Tank. Connect the other end of Gas Line to the "tapered stepped" inlet on right top side of Engine Carburetor. On both ends, push Gas Line on as far as it goes. With pliers carefully compress the ends of the Pinch Clips and slide them to approximately 3/8" from each end of Gas Line.

38. Slip the three remaining plastic coated Retaining Clips over the #45 Gas Line at same intervals as the last three 5/16-18 Weldnuts on underside (rear) of Right #1AR Wall. Similar to Step #36, assemble 5/16 Lock Washer and three 5/16 WI Washers over each end of three 5/16-18 x 1 Cap Screws. Insert each in "slot side" of clip and engage underside of its respective Weldnut. Check that Gas Line follows a smooth path from Gas Tank to Carburetor and that the Retaining Clips lie flat against the underside of its respective Weldnut making sure Gas Line is kept to the left of the Cap Screws. Tighten the three Cap Screws. Insert 5/16-18 x 1 Cap Screw into 5/16 Lock Washer and then into four 5/16 WI Washers; tightly screw this into the remaining (furthest forward) 5/16-18 Weldnut on underside of #1AR Wall.

39. On #550-K19 Heavy Duty Track Chain, connect lengths together using Connector link provided and secure with cotters. (Check to make sure that "offset" tabs on each link are offset to the outside of the Track so that the Track Shoes may bolt flatly against each link.) Loop above chain around Front and Rear Wheels #25 and #22. With both Track Chains in place, draw up on the two 3/8-16 x 4-1/2 Cap Screws in #13 Expanders to tighten the Chains; then lock in place with remaining 3/8 Lock Washer and Nut.

40. Now begin bolting the Track Shoes onto the Drive Chain using the 1/4" Carriage Bolts, Lock Washers, and nuts provided. NOTE: Shoes must be kept square with an imaginary line running from the Front Wheel to Rear Wheel; always check this alignment as you are putting on the Shoes so that the final track will run true. The Lawn Shoes must be bolted on with the bent ends always pointing to the inside of the Track. The Dozer Shoes must be bolted on so that the "gripping" edge of the Shoe is always to the outside and the "rolled" edge of the Shoe is to the inside and points to the rear when it is on the ground. (See Drawing).

41. Locate the #46 Steel Seat Pan such that its four 7/16" holes align with the four 3/8" holes in the "Channel" Bracket on the rear of #4 Cover. (NOTE: You may adjust Seat Forward or Rearward by utilizing only two 3/8" holes in both cases mount with 3/8-16 x 1 Carriage Bolts, secure below "Channel" bracket with 3/8-16 Nuts and Lock Washers.) On optional foam cushion models, work the cushion for the Seat over its Seat Pan making sure the extra pieces of fabric at Cushion's corners are kept over the "sharp" corners of steel Seat Pan. Draw up ends of Seat's drawstring and tie.

42. Locate #24L and 24R Left and Right Mud Fenders under their respective #10L and 10R Left and Right Footwells. Line up the slots in Fenders with their mating 5/16" holes in Footwells. Slip 5/16 WI Washer over the end of eight 5/16-18 x 3/4 Cap Screws and insert (from below Fender) into the slots of Fenders and engage their respective 5/16" hole in Footwells above. Secure above with 5/16 WI Washer and Locknut. (NOTE: "Rear-most" Cap Screw in #24L Fender goes not only through the Fender slot and Footwell hole, but also through the slot in the #6C Brace holding #6 Battery Box above - similarly secure above with 5/16 WI Washer and 5/16-18 Locknut.)

43. Insert #47B Tube of #47 Brake Assembly into #4C Clip welded to the underside of #4A Cover and insert #48 Pin and secure with 5/8 Snap Ring. (NOTE: #47D Strip must be facing underside of #4A Cover). Insert 3/8-16 x 2-1/2 Carriage Bolt into 3/8" sq. hole in underside of #47C Bar and insert into #50 Spring. Insert Carriage Bolt Assembly into underside of forward 3/8 hole of #4A Cover and secure above with 3/8-16 Wing Nut.

44. IMPORTANT: On Models MD1200, 1612 and 1600 - attach Black Edging to the exposed edge of #3B Screen on #3 Hood cover as follows:

A. Cut Edging into two lengths - each 13 $\frac{1}{2}$ " long.

B. Starting with the left rear "exposed edge" of 3B Screen, press the open "V" shaped part of one end of a cut length of edging onto the "exposed edge" of the Screen. Continue to press on edging as you work your way to the right hand side of the "exposed edge" of #3B Screen. NOTE: Be sure that the Black Edging is firmly attached to the exposed edge of #3B Screen to prevent the edging from falling off during operation of the Dozer.

C. Do the same to the "forward exposed edge" of #3B Screen.

#### Final Check of Assembly:

At this point, you must now go completely over the above assembly steps to make sure that you have neither omitted parts, nor installed any parts incorrectly. With spark plug on Engine completely removed from Engine and ignition wire, you may now test your complete Tractor drive train.

A. The first step is to check that when #1K "auxiliary clutch" Handle is pulled forward and engaged in front of #1R Clip that it is sufficient to release tension on #33 Drive Belt so that the #32 Engine Pulley may rotate freely within the #33 Belt thereby causing absolutely no movement of #33 Drive Belt.

The degree of tension in #33 Belt is determined by the location of #27 Idler Pulley in 3/8" wide slot of #1H Segment. Sliding the Idler Pulley forward will decrease tension; sliding it rearward will increase tension. When you have arrived at the position which properly releases #33 Belt, you may then tighten the 3/8-16 x 1-3/4 Cap Screw holding #27 Pulley. (NOTE: When tightening this Cap Screw, hold #23 Handle to resist rotation and check that when Cap Screw is "tight" the #23 Handle is parallel to bottom of Tractor.

In addition, we recommend that the "tension" on #33 Drive Belt be kept somewhat "loose" initially as the Belt being new and not broken in, may be "sticky" and not willing to release its "wrap" on #32 Engine Pulley quite as quickly as it will later. NOTE: After a few hours of use, you will notice the #33 Belt getting somewhat shiny and "broken-in"; at that time, you may reset the tension of #27 Idler Pulley to a finer degree and eliminate any chance of the #33 Belt inadvertently jumping off its pulleys.

B. With #1K "Auxiliary Clutch" Handle released from its position in front of #1R Clip, it will (under #41 Spring's tension) go rearward and thereby tighten #27 Idler Pulley within #33 Drive Belt. With #33 Belt under tension, rotate the two #17 Belt Guides rearward such that they are approximately 1/8" away from outside (or backside) of #33 Belt. Tighten the two Cap Screws to hold the #17 Guides in this position. Similarly with #33 Belt under tension, align #32 Engine Pulley with #30 and 27 Pulleys; then tighten all set screws.

Rotating the Crankshaft of Engine should now operate the #33 Main Drive Belt and cause the top #21 Power Shaft to rotate clockwise (as viewed from right side of Body) and both #15R and 15L Control Handles pushed forward, you should now have both left and Right Tracks going forward. Also, conversely, when you pull back on both #15R and 15L Handles, the Tracks should go rearward.

C. Following Manufacturer's instruction booklet, fill Engine with proper grade of oil and Gas Tank with proper gasoline. Check that you have greased the "Zerk" fittings on both #10 Bearings, #22 Rear Drive Wheels, and #25 Front Idler Wheels. Replace Engine's Spark Plug and ignition wire. Mount #4 Rear Cover over the rear set of four 5/16-18 "studs" sticking out of the top of #1AL and 1AR Body Walls. In a similar manner, mount the #3 Hood (square "cut-out" around #15 Handles) over its set of four forward 5/16-18 "studs". Secure Rear Cover and forward Hood with 5/16-18 "wide-flange" Wing Nuts - hand tighten. Slip #35 Handgrips over end of each #15 Control Handle.

#### Operation:

A. Operator should now mount the Tractor and assume a comfortable sitting position. At this time, he should familiarize himself with the controls: #42 Throttle Control, #43 Choke Control, #1K "Auxiliary Clutch" Handle, #1R Clip and #15R and 15L Clutch Control Handles. (On electric start models, note the #6D Ammeter, #6E Ignition Switch (Stop, Run and Start positions) and #6F Light Switch.)

B. Before starting, move Tractor away from people and immediate obstructions. Move #1K "Auxiliary Clutch" Handle forward and behind #1R Clip to release the #27 Idler Pulley's pressure on #33 Main Drive Belt. Pull up all the way on #42 Throttle Control. You must in addition, pull up on #43 Choke Control for starting when cold.

C. To start 7 hp recoil start Engine: Turn #51 Ignition Switch to "on" position, grasp "pull handle" firmly in right hand and pull up to start Engine. On 12 hp insert "key" in #6E Ignition Switch and turn clockwise to start Engine; when Engine starts, release Key (similar to starting a car.) With Engine running, set the respective Throttle and Choke controls for smooth Engine operation at the particular temperature you are working at.

You may "lock" both Throttle and Choke Controls (in the position you have selected) by rotating the Handles 1/4 turn clockwise. They are "unlocked" by a 1/4 turn counter-clockwise. NOTE: DO NOT "over-tighten" or "over-loosen" these Controls - a 1/4 turn in either direction is sufficient.

D. With Engine running, keep your right hand on the #15L and #15R Control Handles and hold them in the center or neutral position. Simultaneously, with left hand, release #1K "Auxiliary Clutch" Handle from its position in front of (and retained by) #1R Clip and in the direction of the Crankshaft's rotation, while simultaneously the lower #21 Power Shaft should rotate in the reverse direction.

While rotating the Crankshaft clockwise (as viewed from right side of Tractor) push forward on the Left #15L Control Handle and notice how its "outside" #28 Idler Wheel will engage and tighten the #34 Belt wrapped around the #29 Drive Pulley (on outside of left #20 Shaft) and around the #31 Pulley (on left, next to #30 Pulley) on Upper #21 Power Shaft. This action will cause the #29 Pulley to rotate clockwise and subsequently (through the #20 Sprocket and Shaft and the #38 Roller Chain driving the #22 Rear Drive Wheel) cause the Left Track to go forward.

Pulling rearward on the (above) #15L Handle will release the above's #28 Idlers' tension on the first #34 Belt and will then begin to apply tension with the second #28 Idler Wheel onto the second #34 Belt wrapped around the second #29 Pulley (on inside of left #20 Shaft) and its mating #31 Pulley (on left next to #30 Pulley) on Lower #21 Power Shaft. This rearward position of the #15L Handle will cause Track to reverse direction. (Check #15R Control Handle for the same response as above.)

Now, with Engine still rotating, allow it to slowly move rearward (under #41 Spring tension) and set the transmission (upper and lower #21 Power Shafts) in motion. Now, firmly holding a Control Handle (#15R and #15L) in each hand, you can move the Tractor forward by pushing forward on both #15 Handles; move rearward by pulling back on both #15 Handles. Make a right turn by pushing forward on the #15L Control Handle while simultaneously pulling rearward on the Right #15R Control Handle. (Left turns are accomplished by reversing above procedure.)

The Parking Brake is operated by rotating "clockwise" the Wing Nut mounted on top front center of #4A Cover. By tightening this nut, you will draw the #47A Shaft against the back side of all four #34 Clutch Belts - this will "lock-up" the #29 Pulleys and provide a very positive parking brake action. To release the brake, just rotate the Wing Nut "counterclockwise" (only a few turns) until the #47A Shaft rises approximately 1/8" above the #34 Belts - at this setting, take a center punch and up-set the thread directly above the Wing Nut; this will keep the Wing Nut from ever coming off the 3/8-16 x 2-1/2 Carriage Bolt.

NOTE:

For maximum safety both Control Handles must be held by the operator either by a single hand or with both hands while the transmission system is in motion. Therefore, with the transmission in motion, the Control Handles should never be left unattended or the natural action of the transmission will cause them to occasionally bounce back and forth. If this condition takes place, it can be quickly stopped by disengaging the transmission system with the Auxiliary Clutch Handle and then re-starting. If this condition persists, repeat Step #24 in Assembly Instructions and move the respective #28 Idler assemblies forward in their respective slots to relieve this incorrectly adjusted pressure on the #34 Belts. (NOTE: As you gain skill in the driving of your tractor, and as your #34 Belts become shiny and broken in, you may want to move the #28 Idler assemblies rearward for a quicker responding Tractor.)

### Maintenance:

The following items should be checked each time you start your tractor.

1. Gas and Oil should be full and clean - check for any leakages.
2. Grease all Zerk fittings in #10 Bearings, #22 Rear Drive Wheels, and #25 Front Idler Wheels. (When using Tractor in unusually dusty or "gritty" conditions, always repeat greasing every three hours.)
3. Check #33 Main Drive Belt and #34 Clutch Belts for undue wear or fraying - a sign of possible misaligned or improperly adjusted Pulleys or allied components.
4. Check that Wing Nuts on #4 Rear Cover and #3 Hood are tight.
5. Check Track Tension: Tracks should be allowed to be as loose as working conditions permit. Tighten if "Track-jumping" is a problem or if operating in loose gravel or snow.
6. Check Battery water level every three months.
7. Check that #42 Throttle and #43 Choke controls are able to be operated freely without sever binding.
8. Give a "once over" to the complete Tractor looking for loose or misadjusted parts. Vibration or rattling is always a sign of trouble; hence if these conditions appear, stop the Tractor immediately and find out and correct the problem before any further operation of Tractor.

### Belt Changing:

By removing the four 1/4-20 Locknuts holding the two #26 Bearings against the "outside" of #1AR Body Wall (and loosening the set screws in the two remaining #26 Bearings), you will be able to slide both the Upper and Lower #21 Power Shafts to the right which will allow room at the left to slip all Belts on and off.

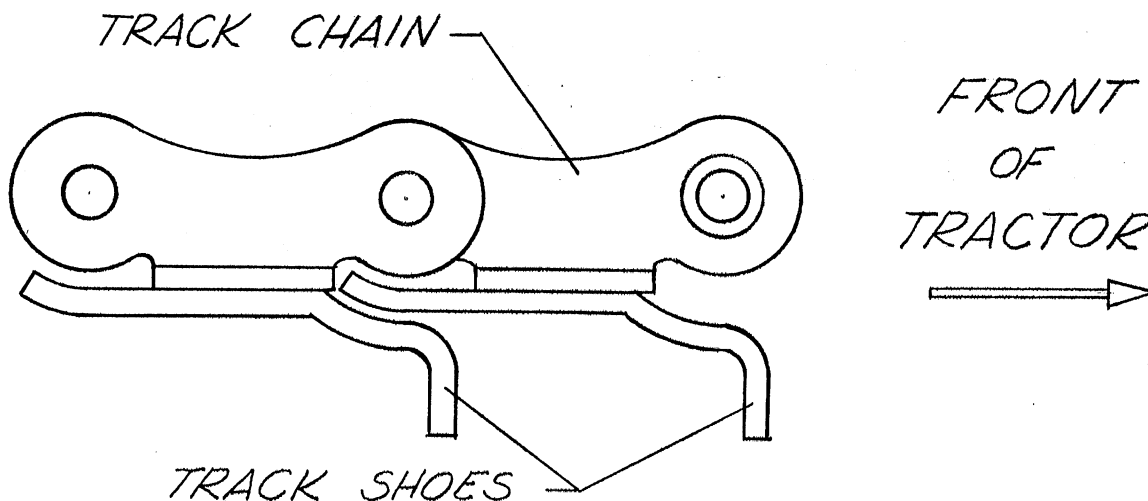

Drawing for Step 40



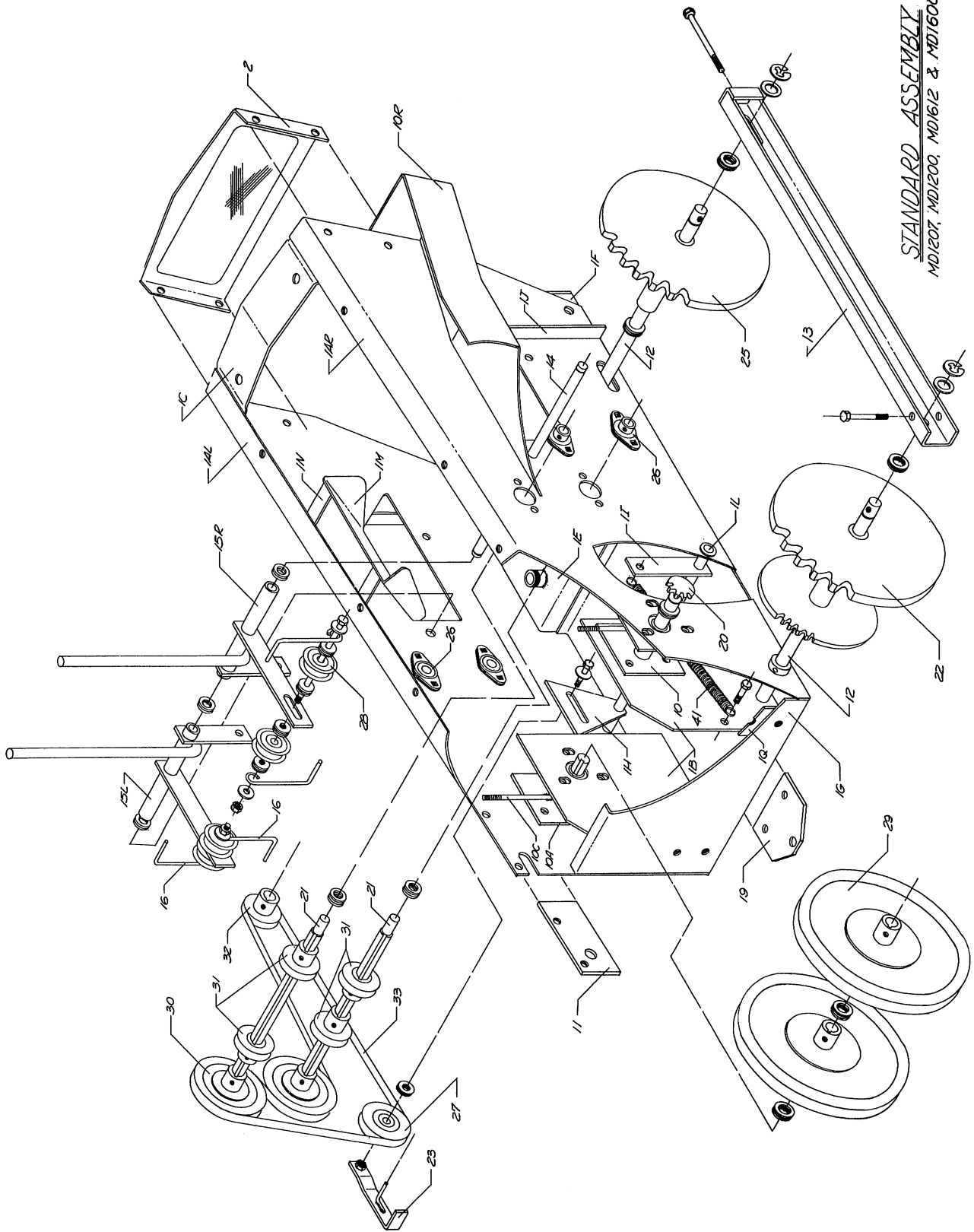

STANDARD ASSEMBLY  
 MD1207, MD1200, MD1612 & MD1600

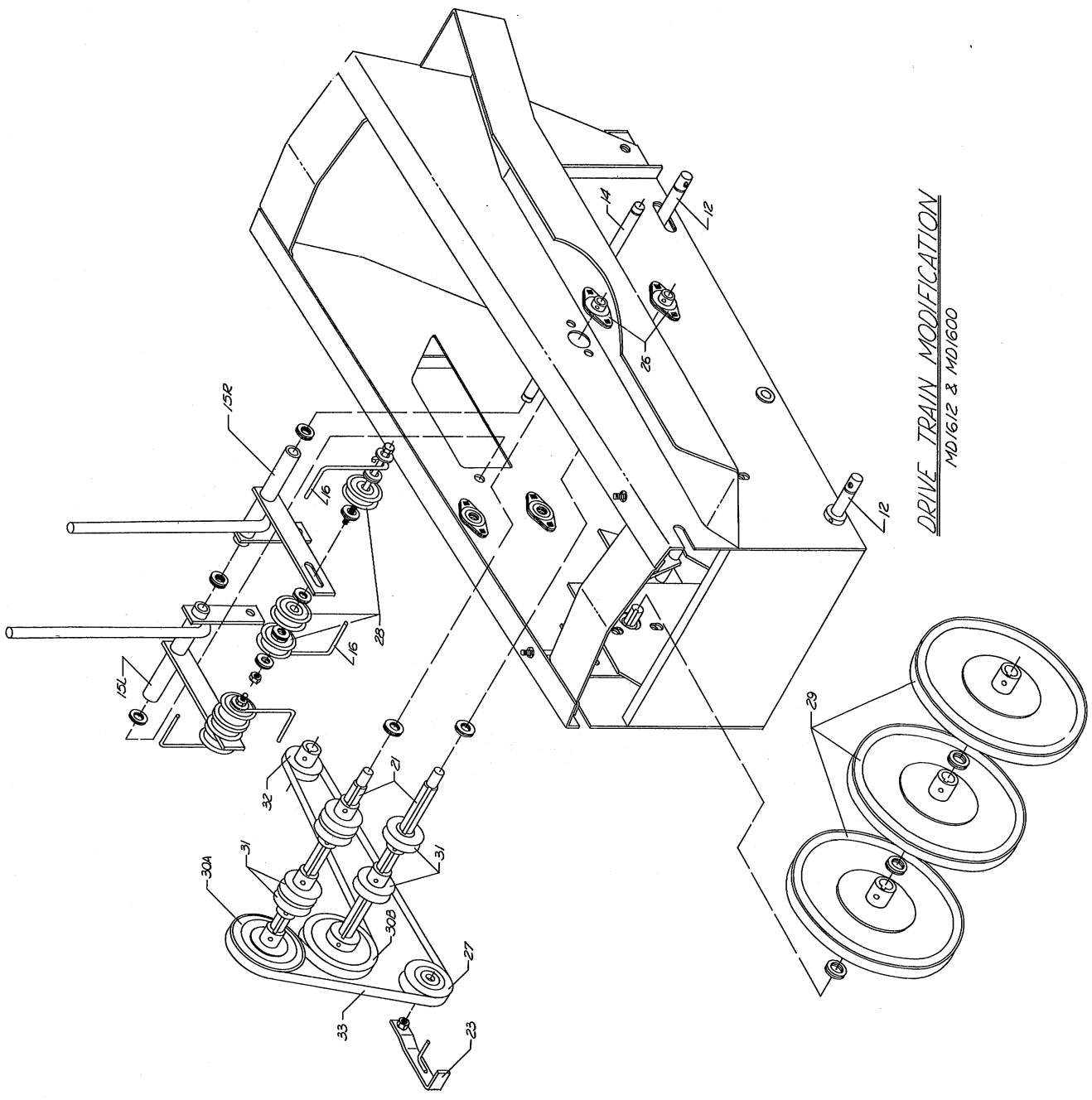

DRIVE TRAIN MODIFICATION  
MD1612 & MD1600

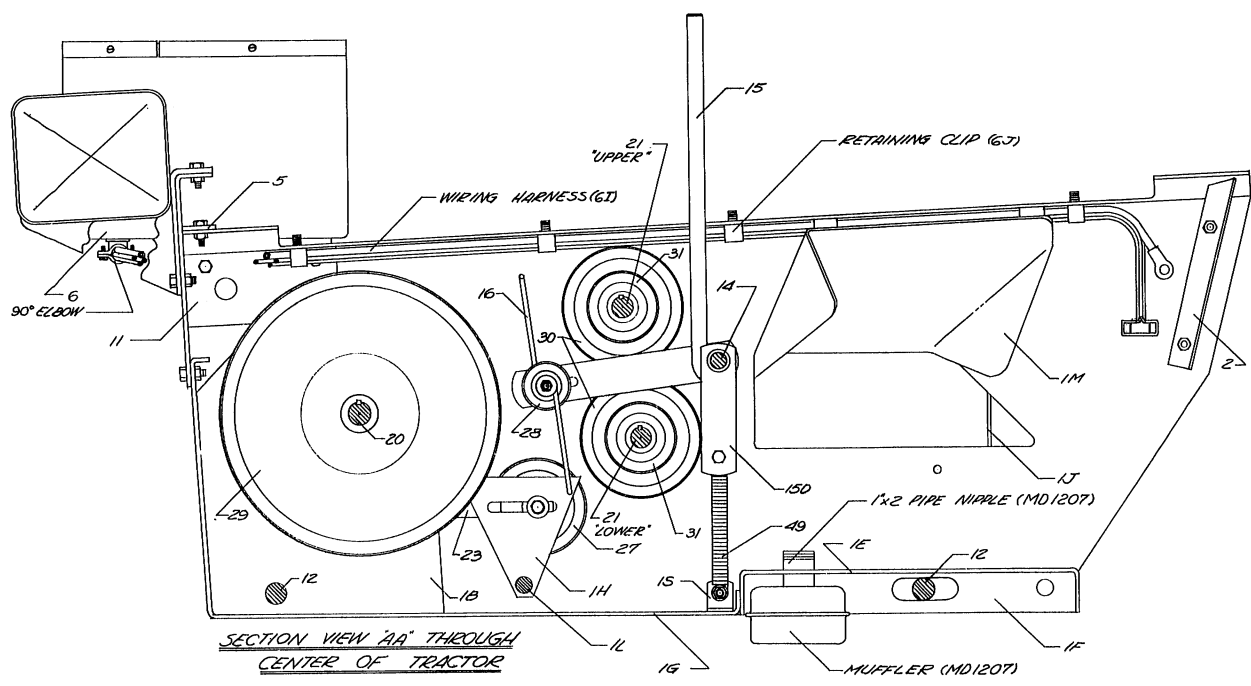
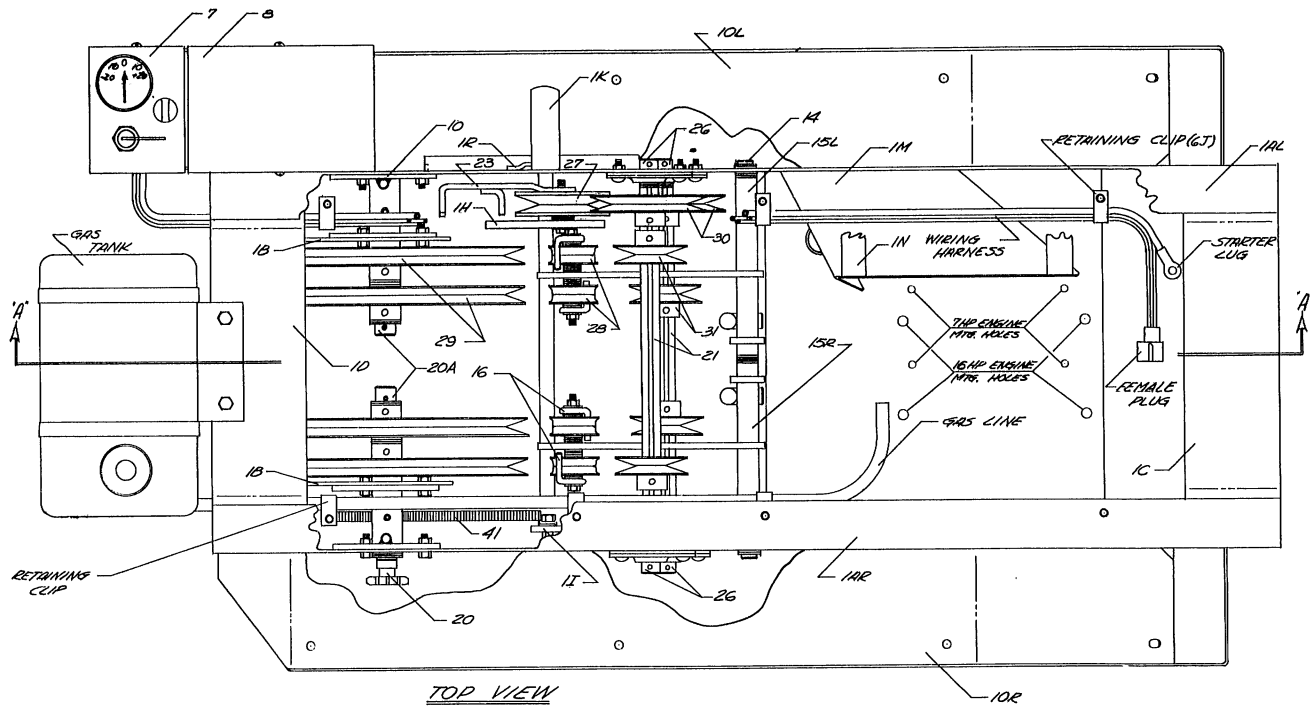

**STANDARD ASSEMBLY**  
 MD1207, MD1200, MD1612 & MD1600

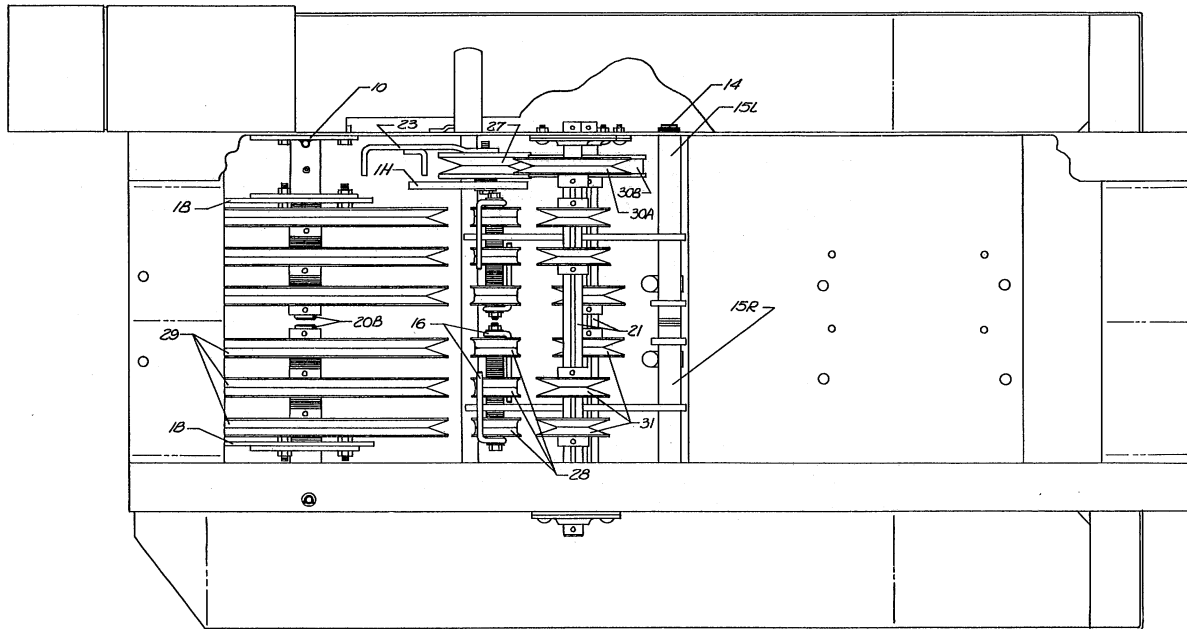

DRIVE TRAIN MODIFICATION  
MD1612 & MD1600

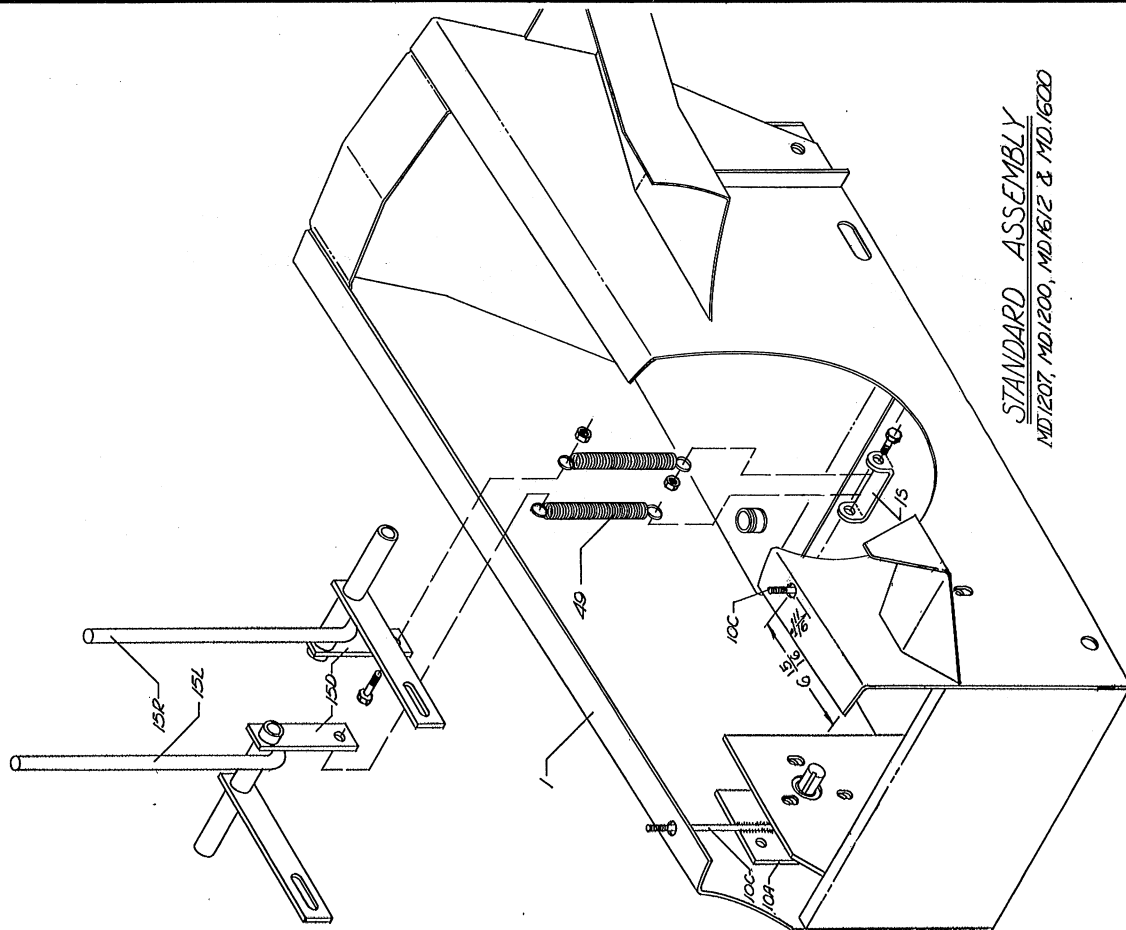

STANDARD ASSEMBLY  
MD1207, MD1200, MD1612 & MD1600

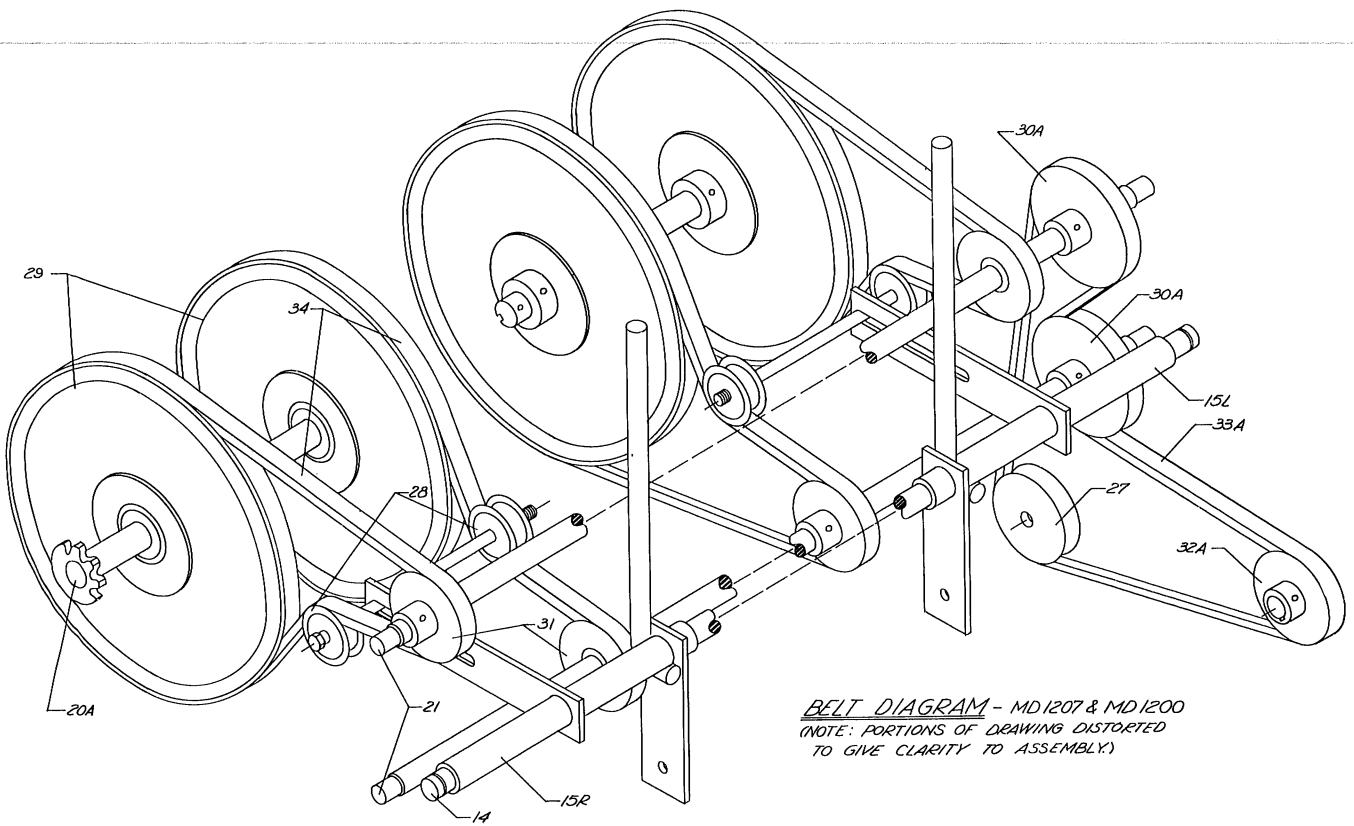

BELT DIAGRAM - MD1207 & MD1200  
 (NOTE: PORTIONS OF DRAWING DISTORTED  
 TO GIVE CLARITY TO ASSEMBLY.)

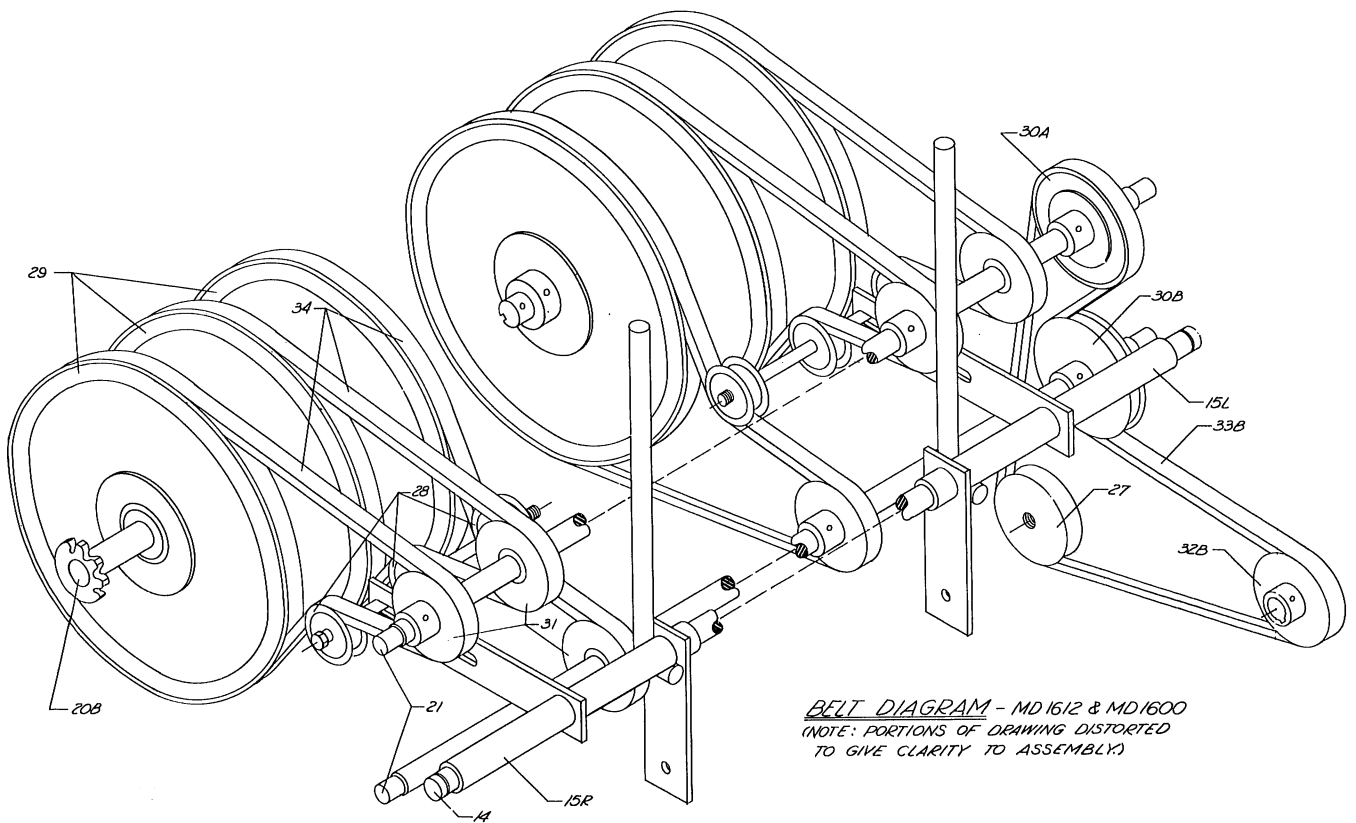

BELT DIAGRAM - MD1612 & MD1600  
 (NOTE: PORTIONS OF DRAWING DISTORTED  
 TO GIVE CLARITY TO ASSEMBLY.)

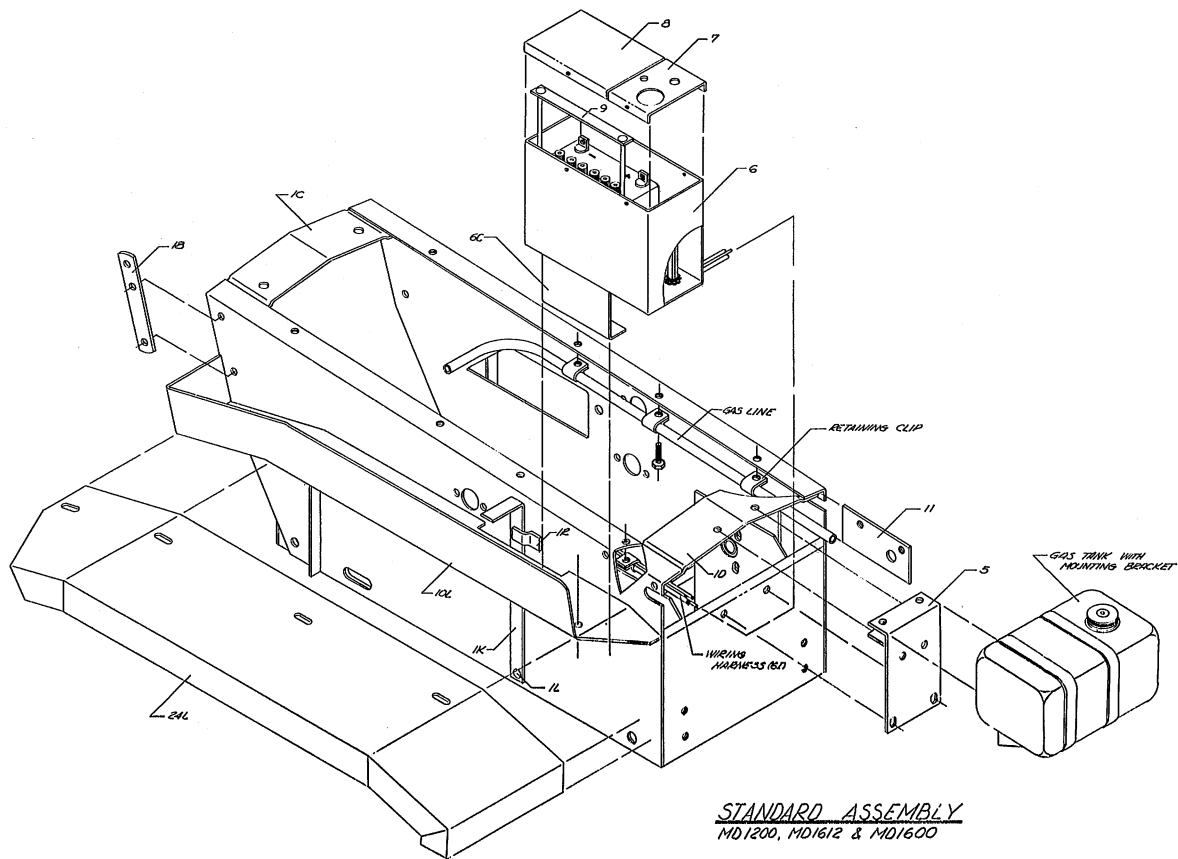
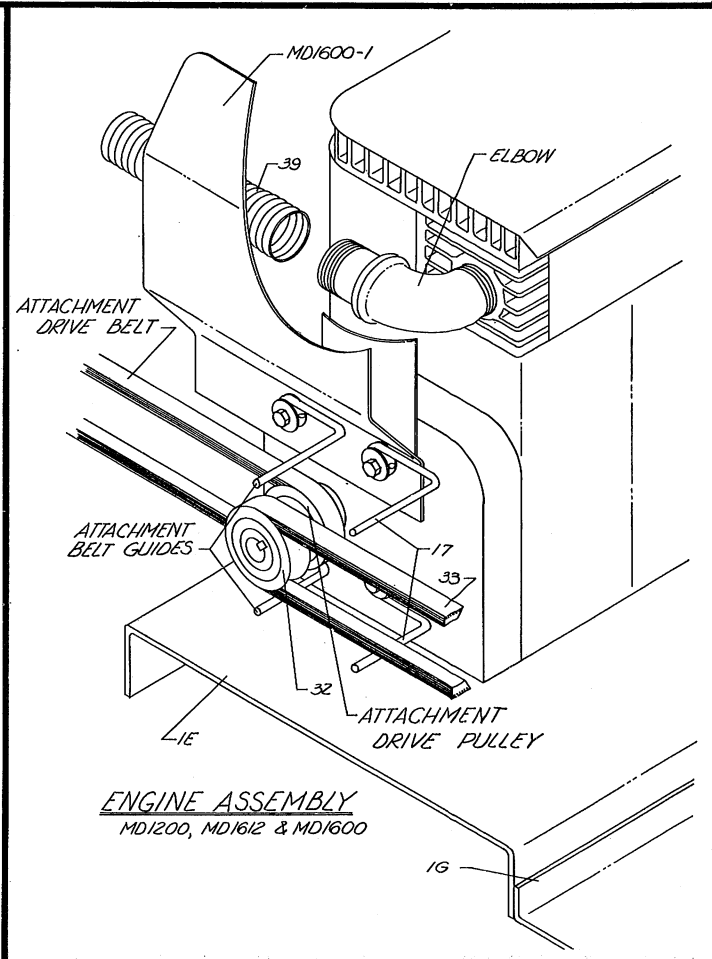
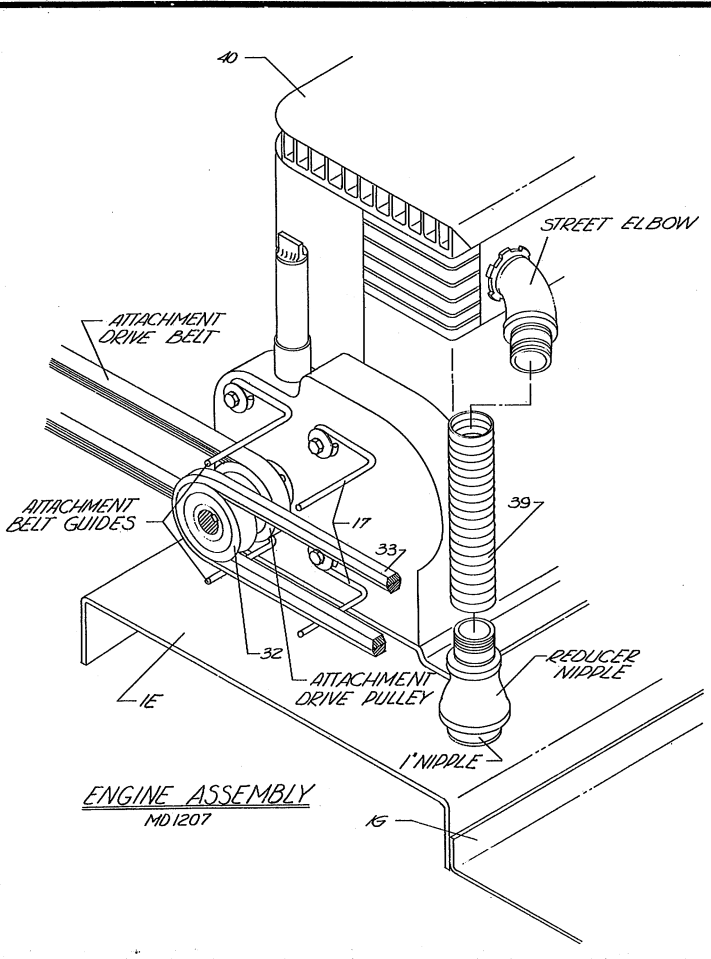

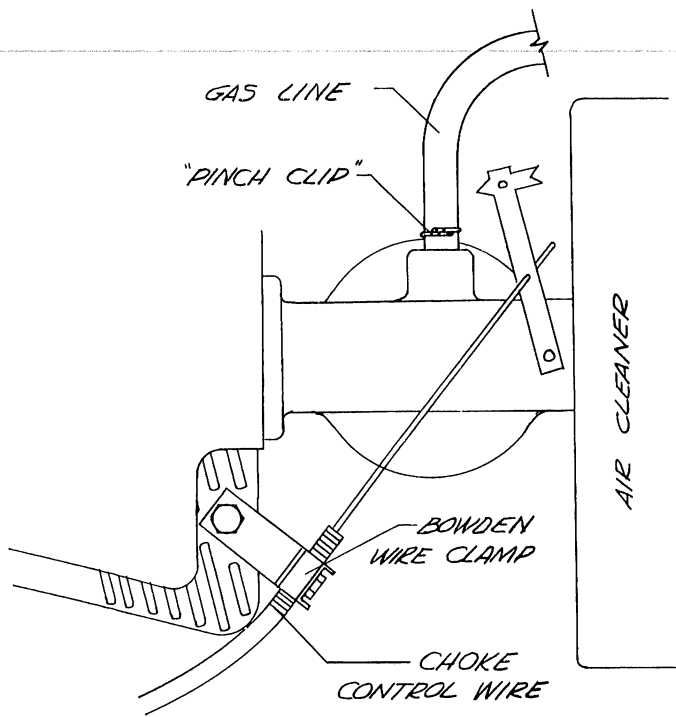

CHOKE CONTROL

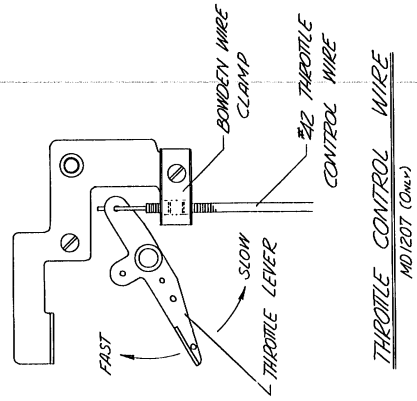

THROTTLE CONTROL WIRE  
MD 1207 (Cont.)

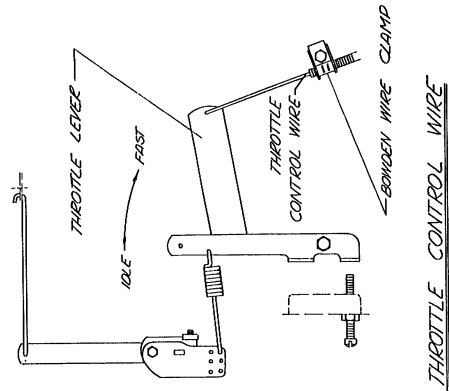

THROTTLE CONTROL WIRE

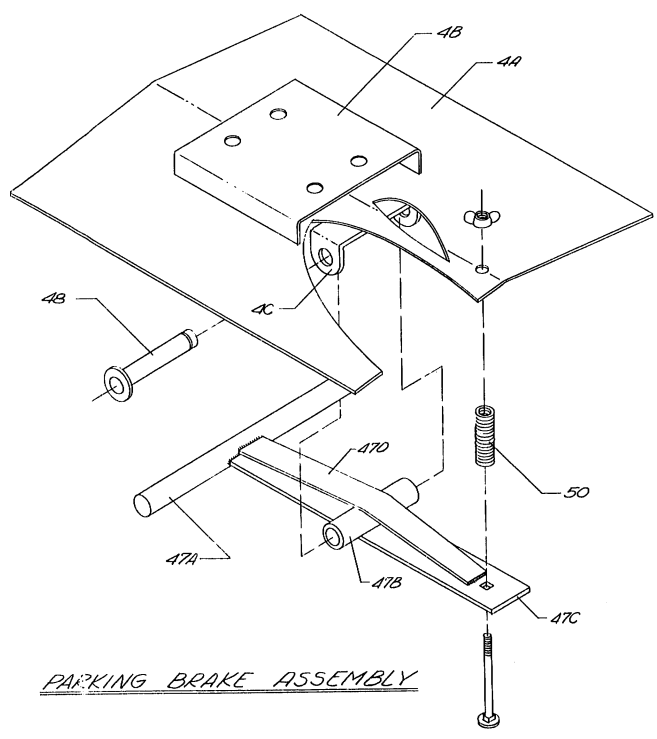

PARKING BRAKE ASSEMBLY

ELECTRIC CIRCUIT  
MD 1207

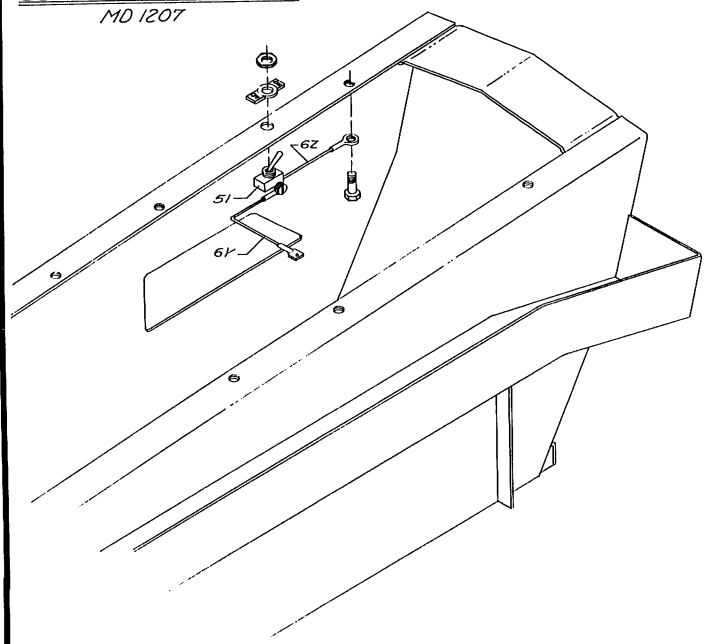

NOTE: \*6I WIRING HARNESS MADE UP OF WIRES #6N, 6P, 6S & 6T.

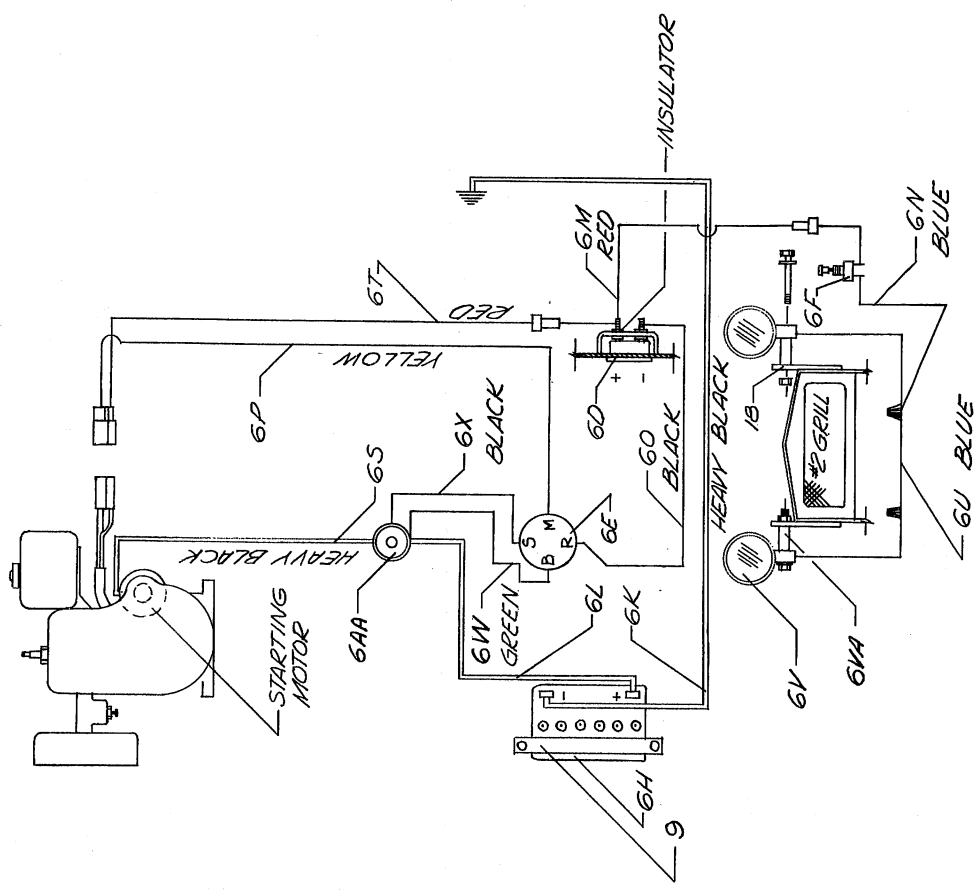

ELECTRIC START CIRCUIT

WIRING DIAGRAM

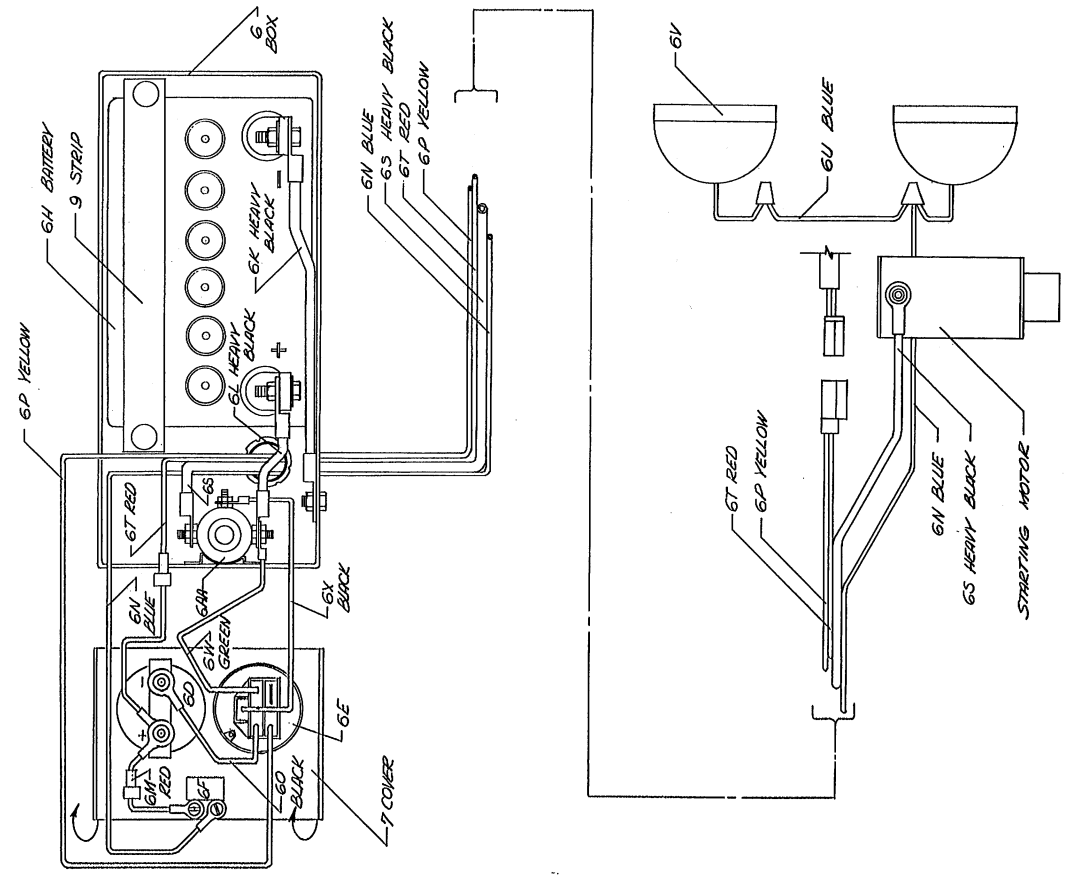



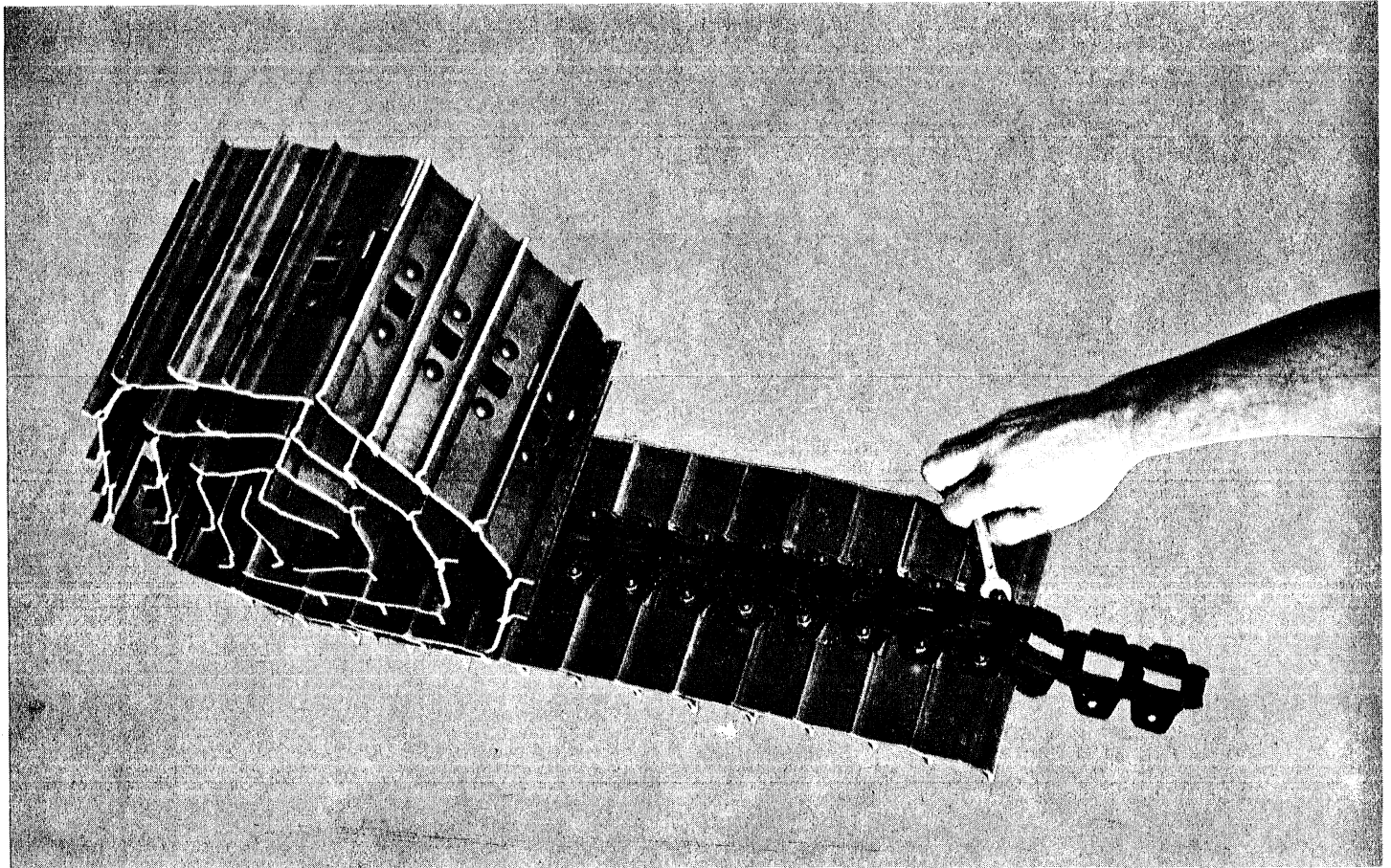
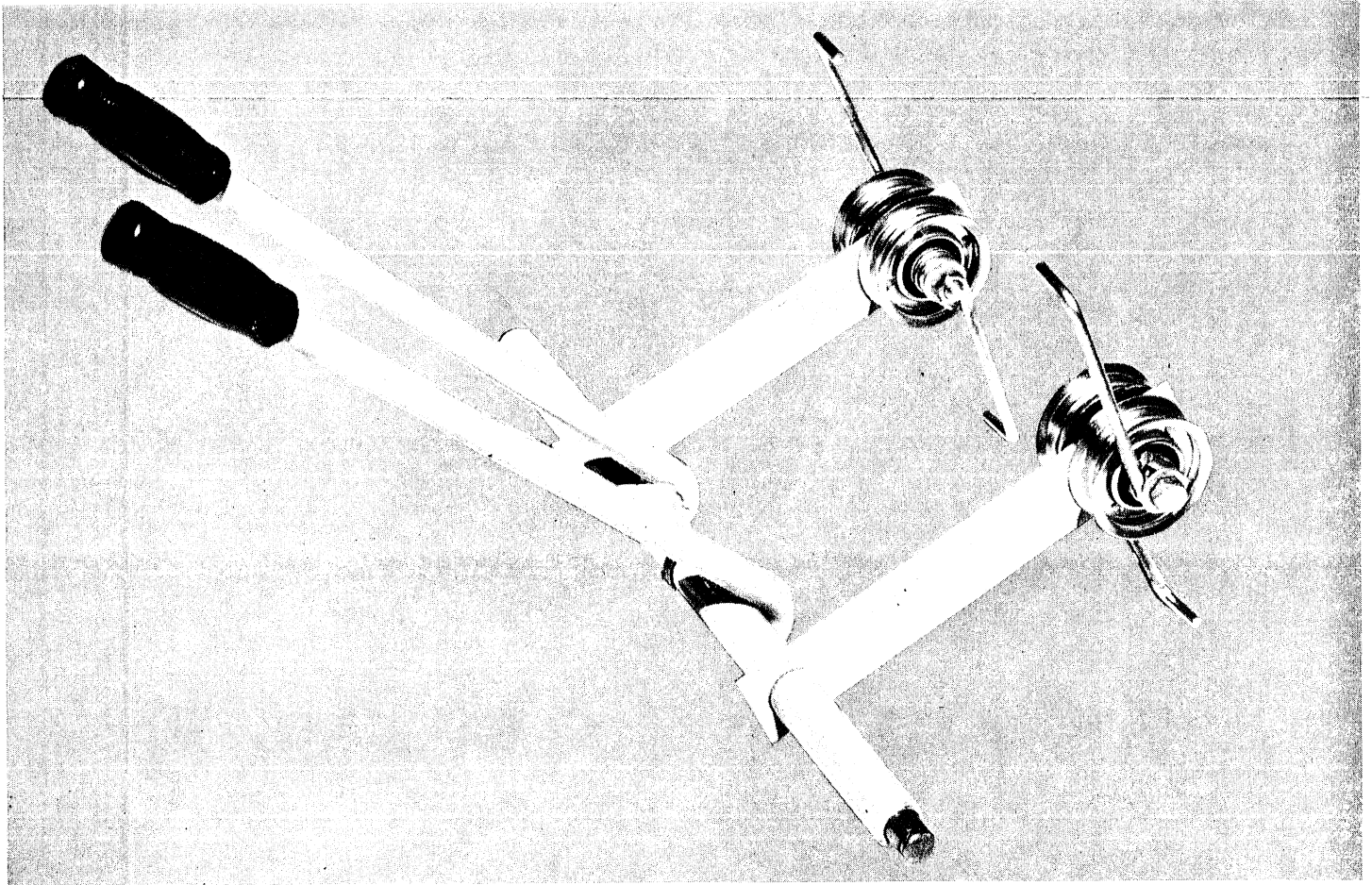

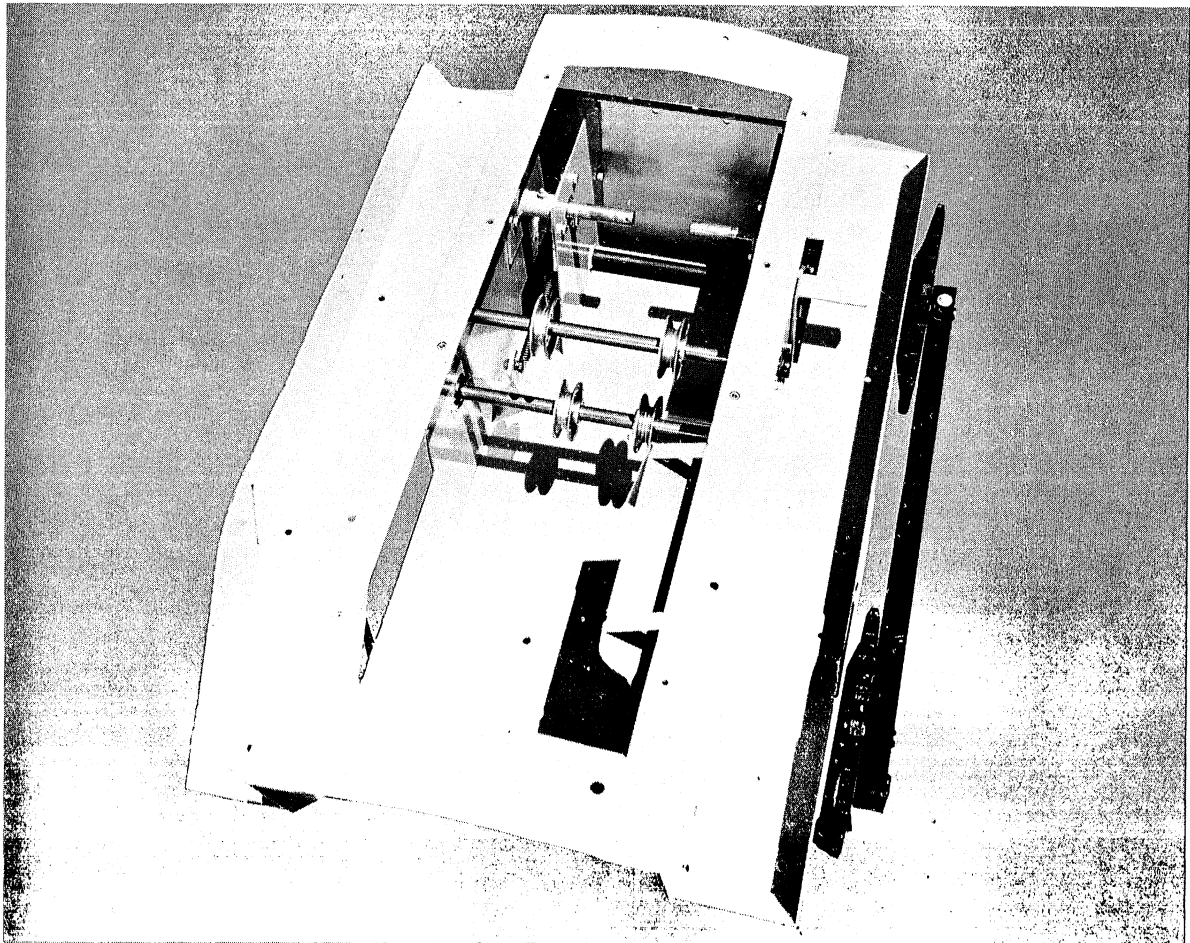
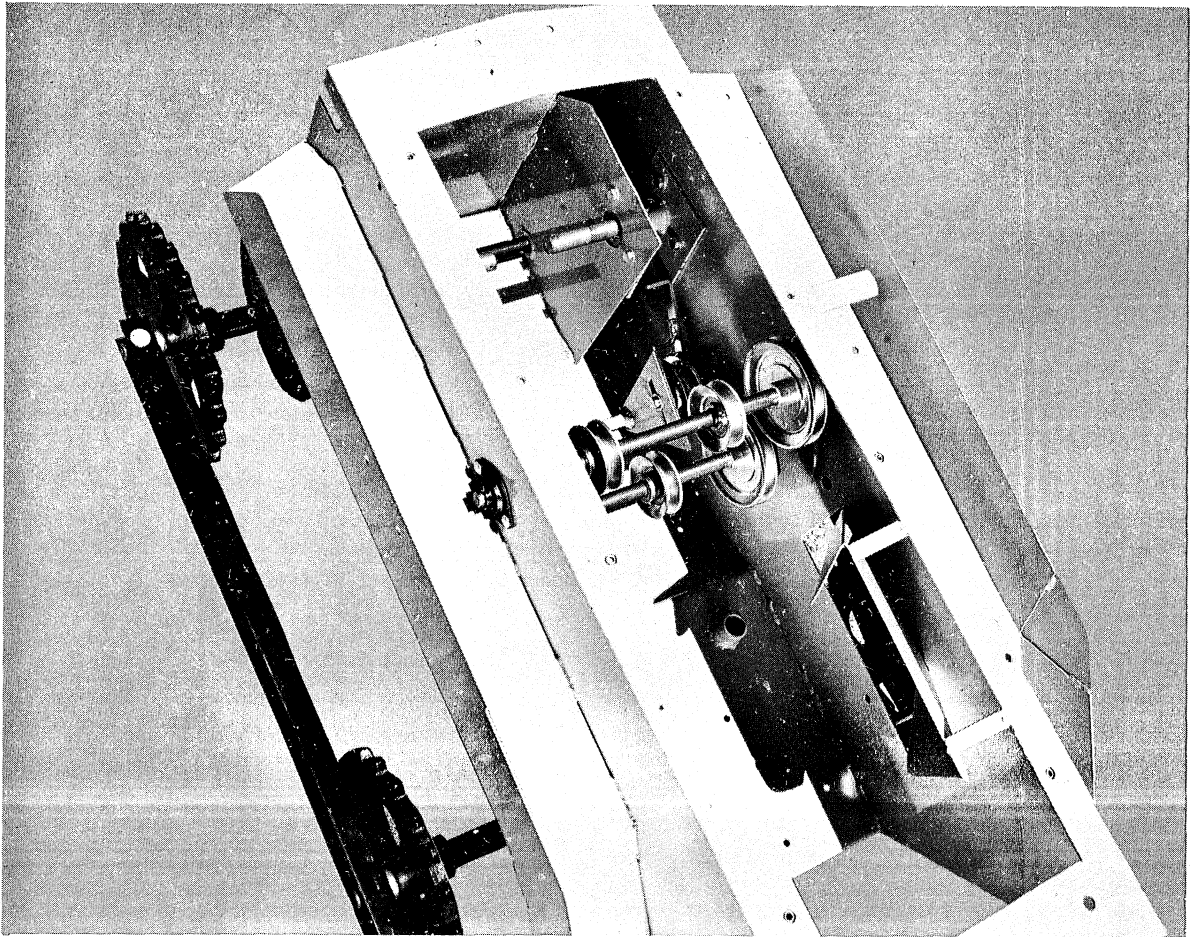

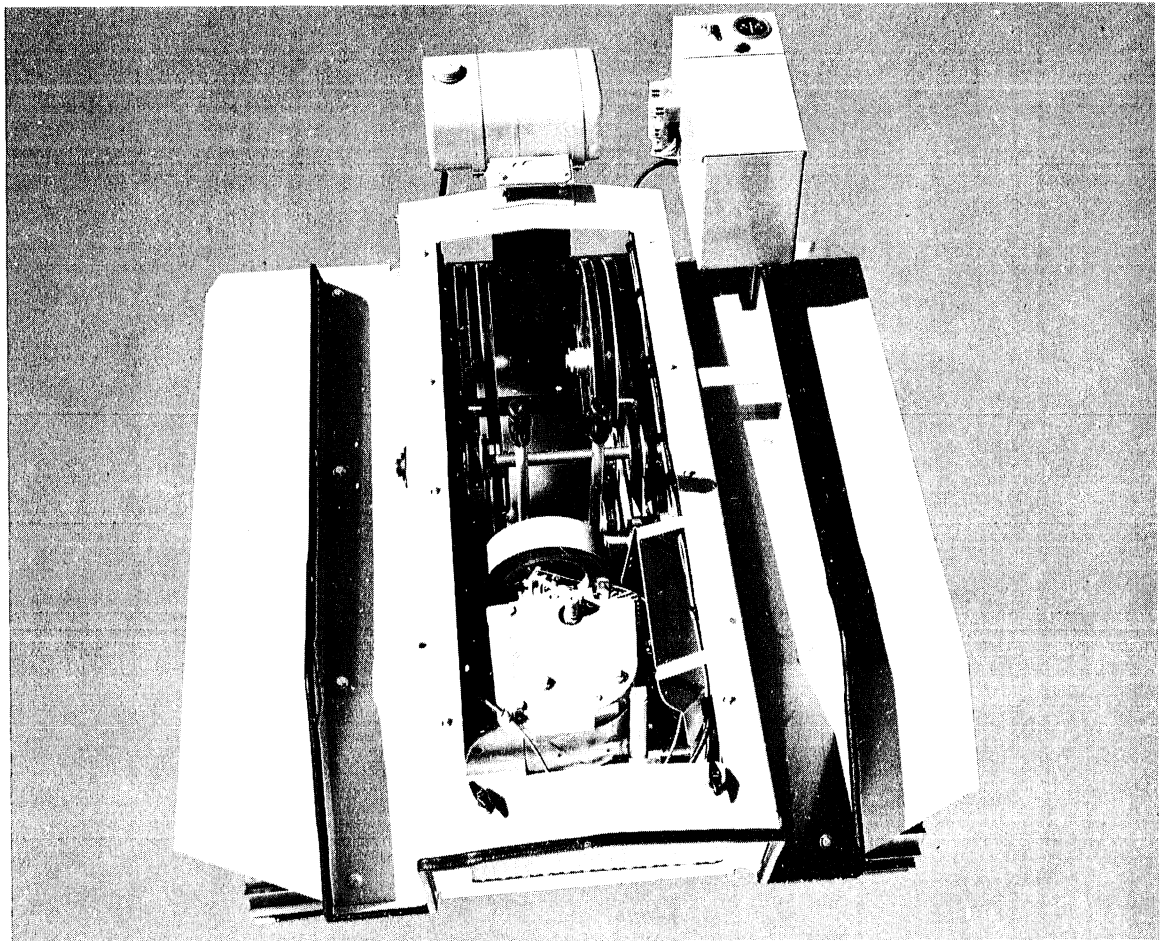
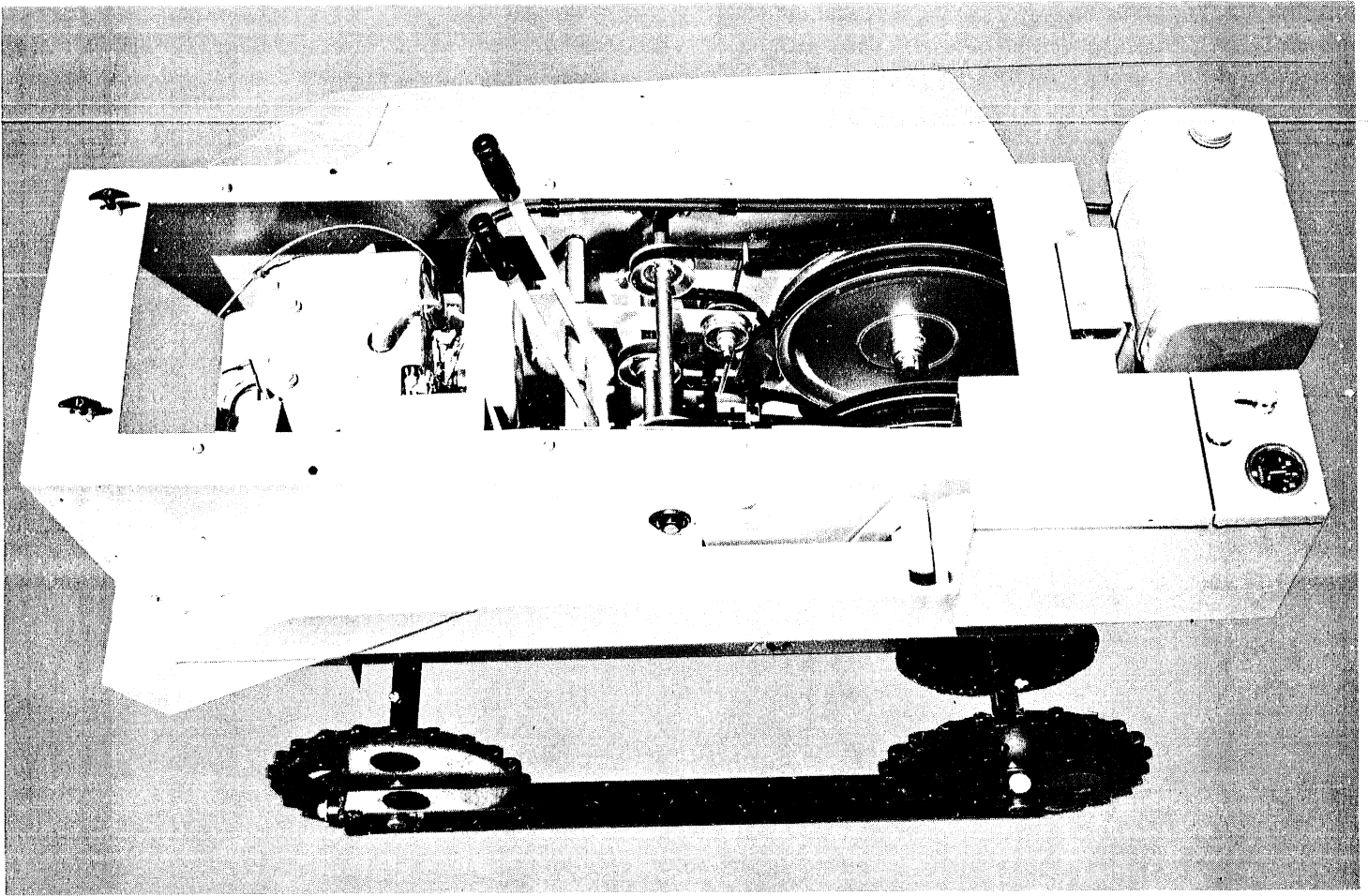

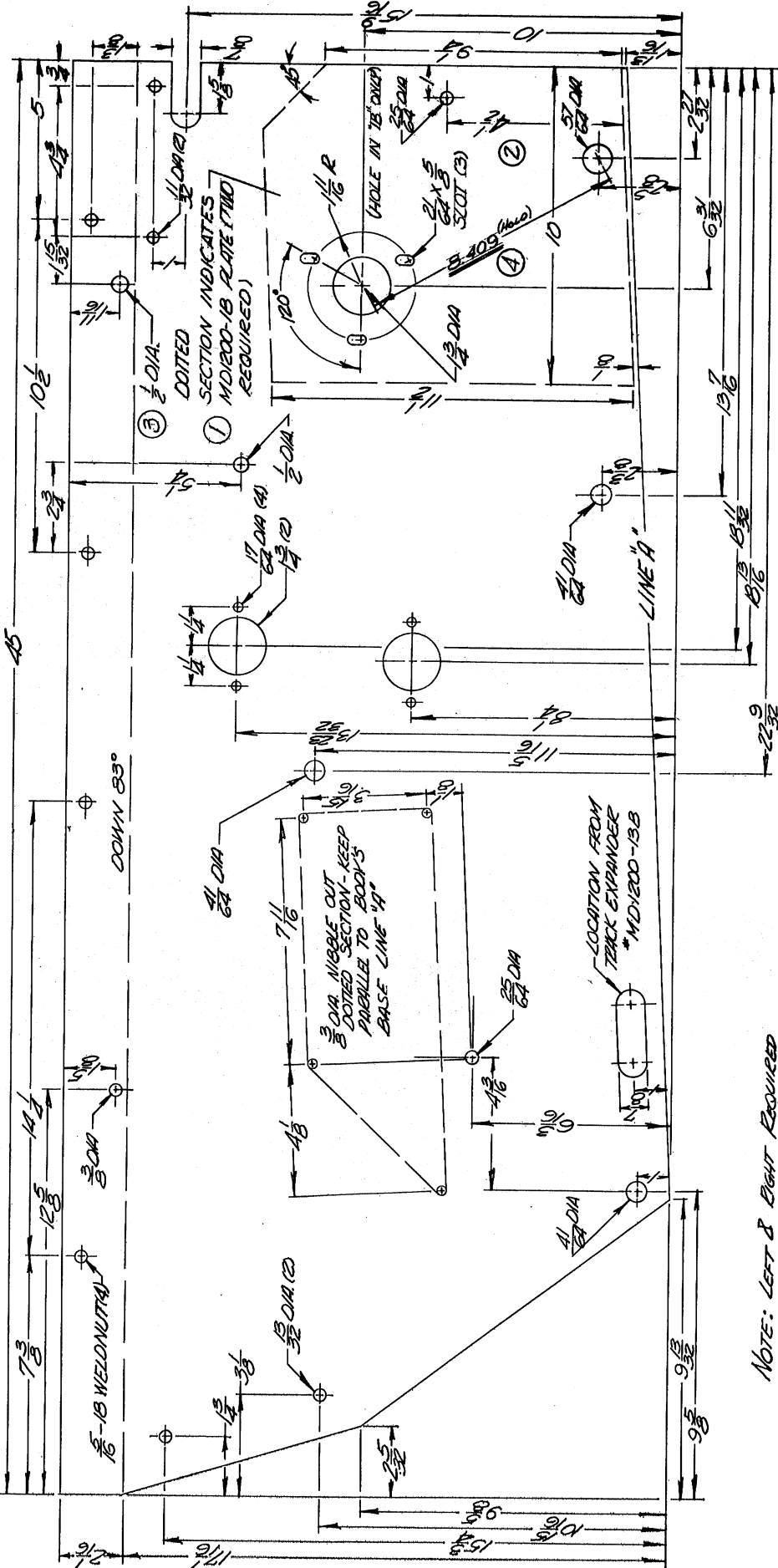

REVISIONS	DATE	BY
1	11-5-73	CAF
2	12-19-73	CAF
3	3-22-74	CAF
4	2-11-77	CAF

MD1200-1A WALL  
C.F. STRUCK CORP.  
Addition -  
AW Tolrance  
5-16-77  
12-84 CFS

NOTE: LEFT & RIGHT REQUIRED

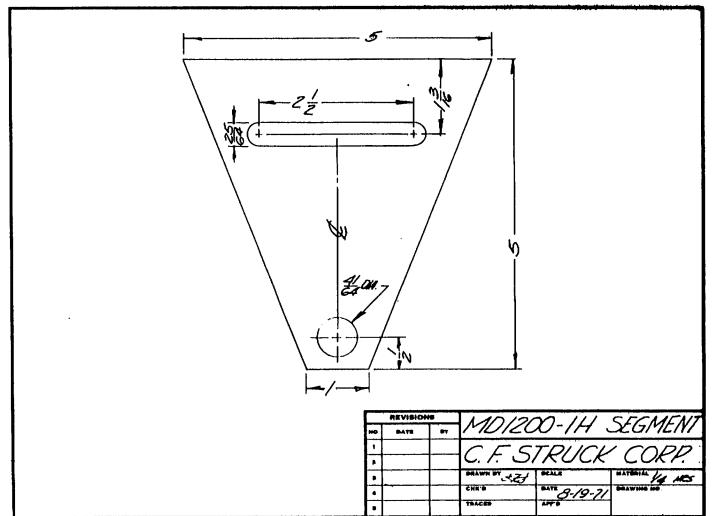
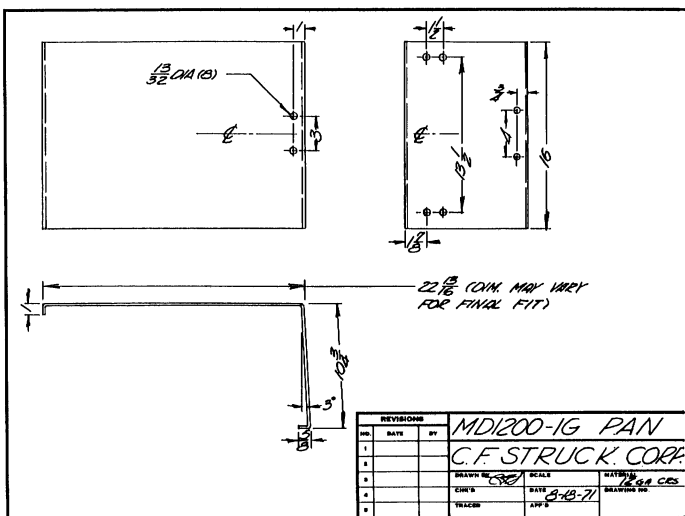
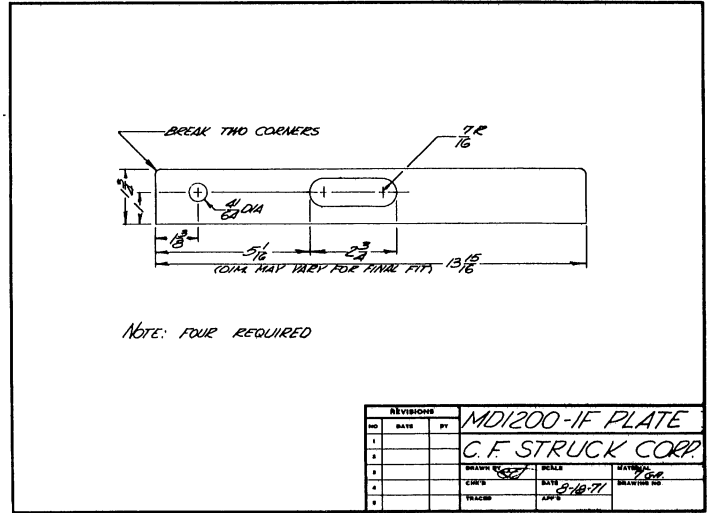
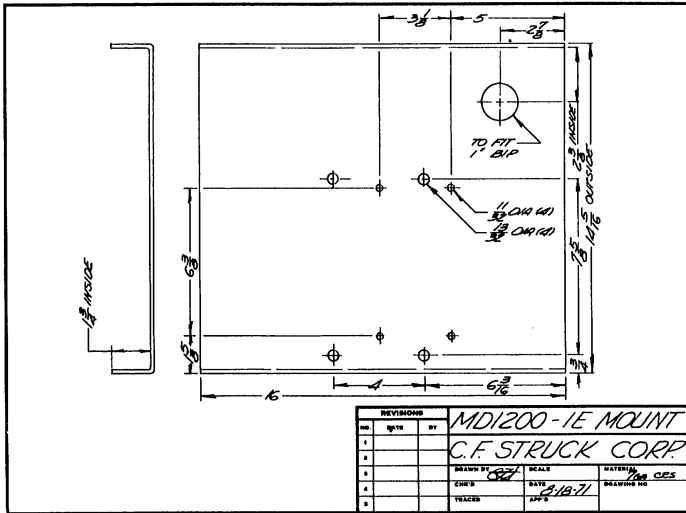
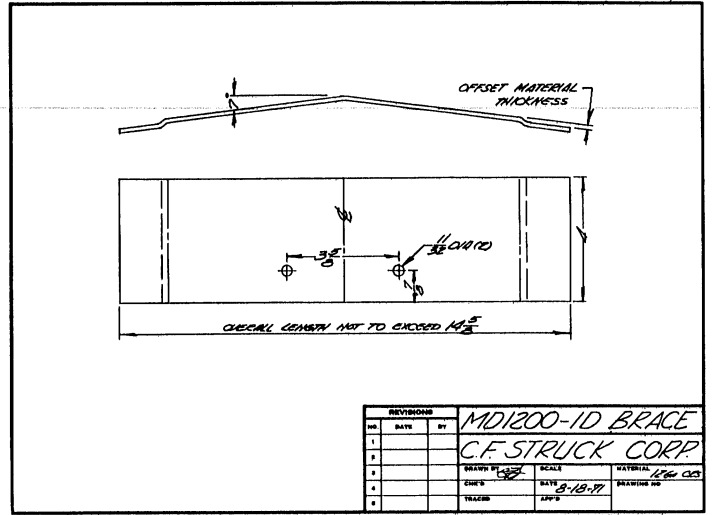
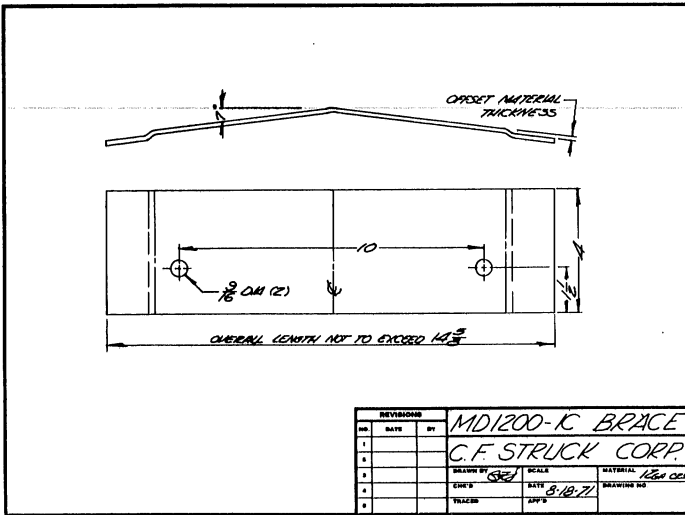

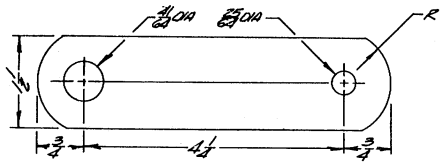

REVISIONS			MD1200-1I BAR			
NO.	DATE	BY	C.F. STRUCK CORP.			
1			DRAWN BY	SCALE	MATERIAL	
2			CHK'D	DATE	DRAWING NO.	
3			TRACED	APP'D		

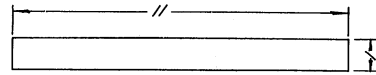

NOTE: MAKE 2

REVISIONS			MD1200-1J BRACE			
NO.	DATE	BY	C.F. STRUCK CORP.			
1			DRAWN BY	SCALE	MATERIAL	
2			CHK'D	DATE	DRAWING NO.	
3			TRACED	APP'D		

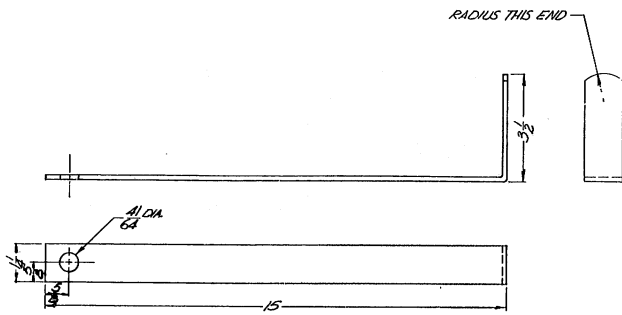

REVISIONS			MD1200-1K HANDLE			
NO.	DATE	BY	C.F. STRUCK CORP.			
1			DRAWN BY	SCALE	MATERIAL	
2			CHK'D	DATE	DRAWING NO.	
3			TRACED	APP'D		

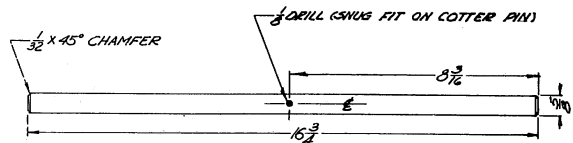

REVISIONS			MD1200-1L ROD			
NO.	DATE	BY	C.F. STRUCK CORP.			
1			DRAWN BY	SCALE	MATERIAL	
2			CHK'D	DATE	DRAWING NO.	
3			TRACED	APP'D		

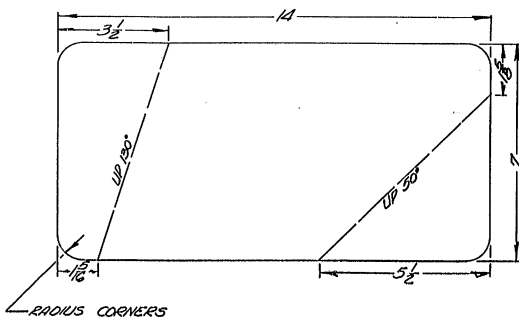

REVISIONS			MD1200-1M BAFFLE			
NO.	DATE	BY	C.F. STRUCK CORP.			
1			DRAWN BY	SCALE	MATERIAL	
2			CHK'D	DATE	DRAWING NO.	
3			TRACED	APP'D		

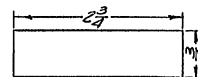

NOTE: TWO REQUIRED

REVISIONS			MD1200-1N STRIP			
NO.	DATE	BY	C.F. STRUCK CORP.			
1			DRAWN BY	SCALE	MATERIAL	
2			CHK'D	DATE	DRAWING NO.	
3			TRACED	APP'D		

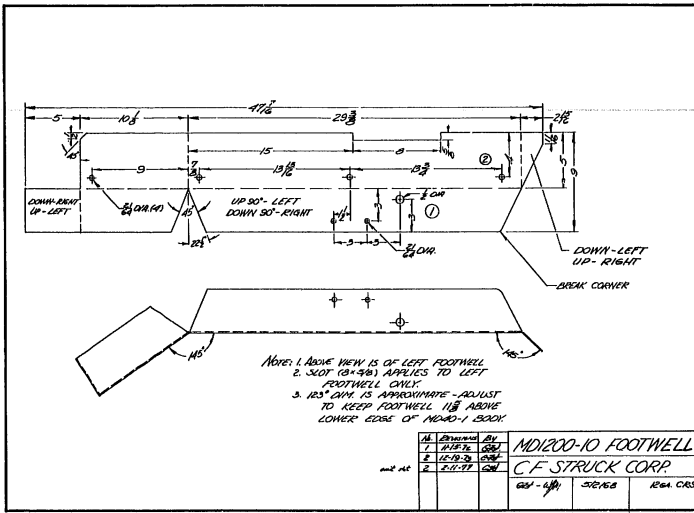

REVISIONS			MD1200-10 FOOTWELL		
NO.	DATE	BY	NO.	DATE	BY
1					
2					
3					
4					
5					

DRAWN BY: JET SCALE: MATERIAL: 1/2" ALUM.  
CHECKED: JET DATE: 8-19-71  
TOLERANCES: UNLESS OTHERWISE SPECIFIED

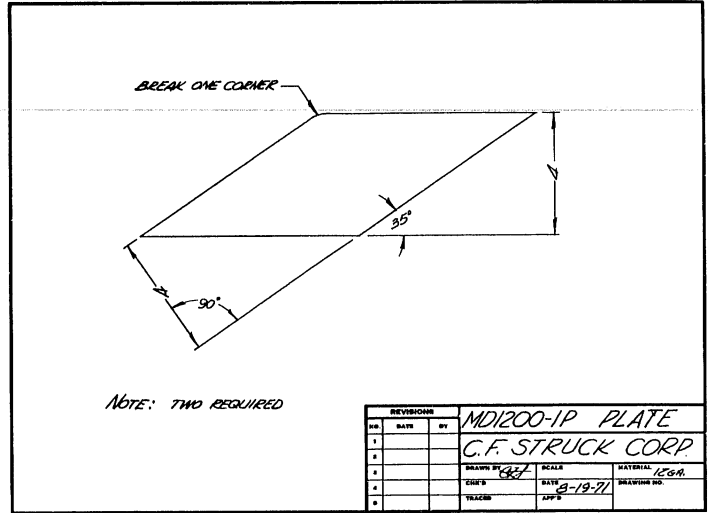

REVISIONS			MD1200-1P PLATE		
NO.	DATE	BY	NO.	DATE	BY
1					
2					
3					
4					
5					

DRAWN BY: JET SCALE: MATERIAL: 1/2" ALUM.  
CHECKED: JET DATE: 8-19-71  
TOLERANCES: UNLESS OTHERWISE SPECIFIED

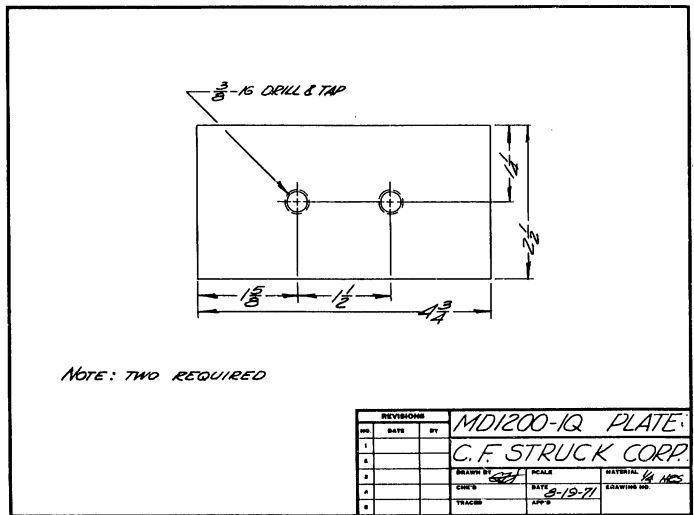

REVISIONS			MD1200-1Q PLATE		
NO.	DATE	BY	NO.	DATE	BY
1					
2					
3					
4					
5					

DRAWN BY: JET SCALE: MATERIAL: 1/2" ALUM.  
CHECKED: JET DATE: 8-19-71  
TOLERANCES: UNLESS OTHERWISE SPECIFIED

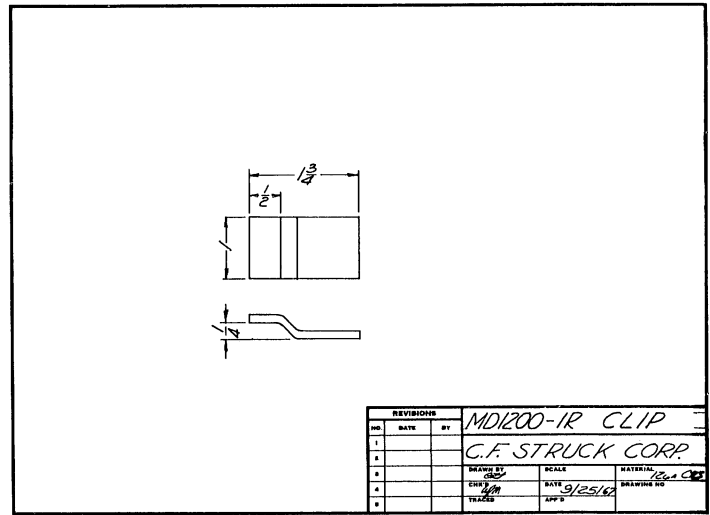

REVISIONS			MD1200-1R CLIP		
NO.	DATE	BY	NO.	DATE	BY
1					
2					
3					
4					
5					

DRAWN BY: JET SCALE: MATERIAL: 1/2" ALUM.  
CHECKED: JET DATE: 8/25/71  
TOLERANCES: UNLESS OTHERWISE SPECIFIED

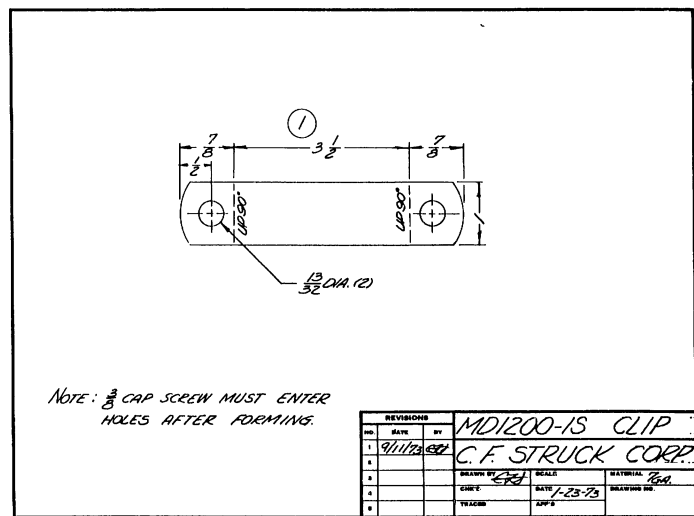

REVISIONS			MD1200-1S CLIP		
NO.	DATE	BY	NO.	DATE	BY
1	9/11/71	JET			
2					
3					
4					
5					

DRAWN BY: JET SCALE: MATERIAL: 1/2" ALUM.  
CHECKED: JET DATE: 9-23-71  
TOLERANCES: UNLESS OTHERWISE SPECIFIED

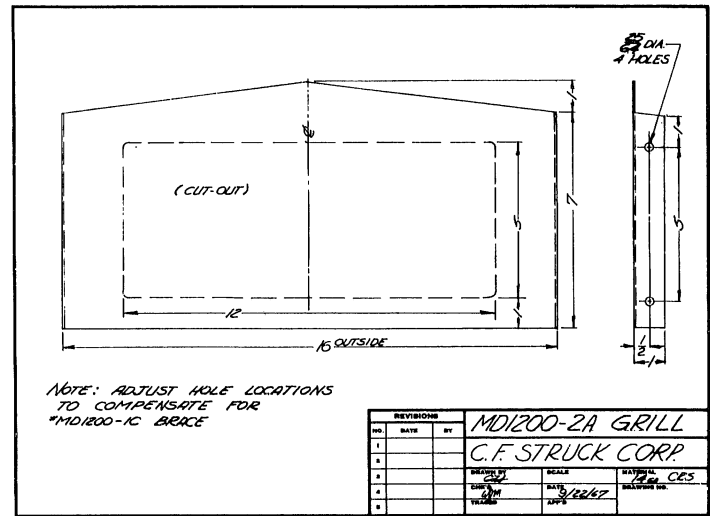

REVISIONS			MD1200-2A GRILL		
NO.	DATE	BY	NO.	DATE	BY
1					
2					
3					
4					
5					

DRAWN BY: JET SCALE: MATERIAL: 1/2" ALUM.  
CHECKED: JET DATE: 9/26/71  
TOLERANCES: UNLESS OTHERWISE SPECIFIED

