

BUYER'S GUIDE

Specifications & Attachments

MD196K

Build it Yourself... D-I-Y Kit

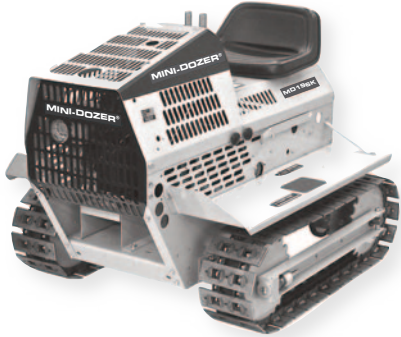

SPECS

	MD	RS
Type	D-I-Y Kit,	Assembled
As Shipped	Unpainted	Painted
Engine Brand	Briggs	Honda
Engine Size	[250cc]	[390cc]
Engine Torque	11.5 ft/lbs	18.5 ft/lbs
Starting Type	Recoil	Electric
Bearing Type	Standard	Heavy-Duty
Track Clutches	4 total	6 total
Brakes	Single	Dual
Drawbar Pull	1,000 lbs.	1,500 lbs.
Width	41" wide	41" wide
Length x Height	51" x 38"	51" x 38"
Base Weight	575 lbs.	700 lbs.
Max. Speed	3.15 MPH	3.15 MPH
Attachment Type	Manual	Hydraulic

RS1000

Factory Assembled...

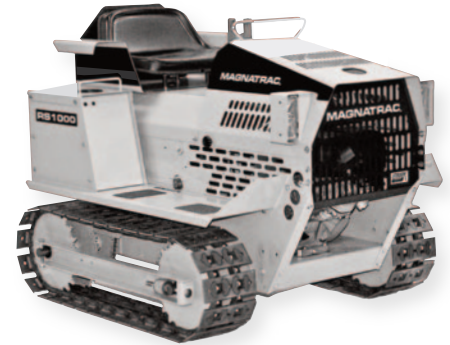

MD196K Front Attachments

MANUAL FRONT HITCH KIT - Standard-duty front lifting system. Channel is 3-3/8" tall. Comes complete with dual sets of "lift assist" springs, lift handle and all hardware.

29 lbs. of force on the lift handle will raise a 95 lb. Dozer Blade, 50 lb. Bucket Mouth and a "186 lb. load of dirt, rock, etc. That's over 330 lbs.!

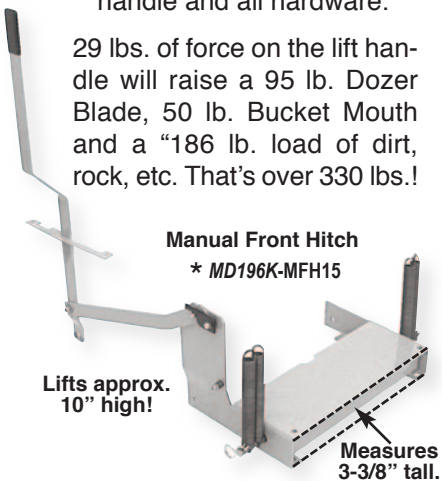

BUCKET MOUTH KIT - Attaches to MD196K-DB44 Dozer Blade with 2 pins! Forms a "mouth" with the Blade and becomes a "clam shell" style bucket. Handles a couple 100 lbs. of dirt, gravel, etc. Dumps with a simple hand lever, not shown.

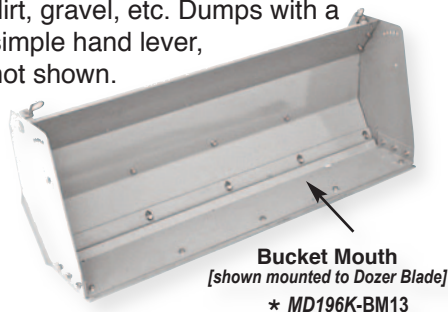

MD196K & RS1000 Front Attachments

DOZER BLADE KIT - 42" wide x 15" high x 7GA solid steel, 3 position adjustable blade with replaceable cutting edge. Slotted bolt holes on cutting edge, allow a "slight angle" for driveway maintenance. Angles left and right by moving 1 bolt. Requires Manual or Hydraulic Front Hitch.



BLADE DRAWBAR KIT - Mounts to "top lip" of DB44 Dozer Blade. 9-1/4" wide drawbar with 45° bend. Use for medium-duty pulling. Has 3/4" hole for tow hook or chain clevis. Requires drilling four 5/16" holes in Blade.

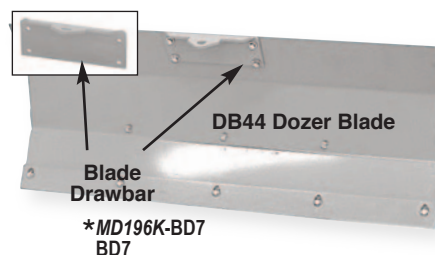

* Unpainted attachment.

RS1000 Front Attachments

HYDRO FRONT HITCH KIT - Heavy-duty front mounted hitch for easy hydraulic lifting. With "finger-tip" control you can easily move 100's of lbs of soil, manure, sand etc. (Assembled, requires PP35 Power Pack, page 4).

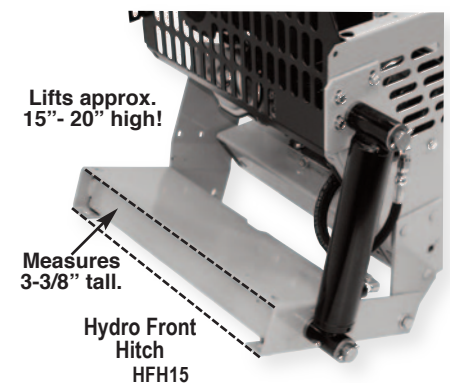

BOX SCRAPER KIT - Attaches to DB44 Dozer Blade to trap and move material. 42" wide x 12+" deep x 18+" high. Hardened and beveled "plow steel" cutting edge. Box scraper shown below mounted to DB44 Dozer Blade.



RS1000 Front Attachments Continued

MATERIAL BUCKET KIT (Manual Dump or Hydro Dump) - Front mounted, heavy-duty, 42-1/2" wide x 12-3/4" high x 13-1/2" deep bucket with hardened cutting edge. 350 lb. rated load. Rear "counterweight" required for maximum loads. Choose **BK45 Bucket to Hydraulically dump or BK44 to Manually dump** with trip handle shown below.



Material Bucket Kit BK44 Manual Dump shown

HITCH EXTENDER KIT - Moves attachment "mounting holes" of Hydro Front Hitch 6" forward. Required for use with D1060UG Backhoe and BK45 Material Bucket Kit.

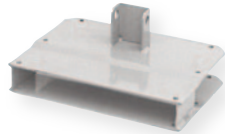

Hitch Extender HE47

FRONT WEIGHT KIT - 4" diameter steel weight bar, welded to plates and mounted to the front of RS1000. Necessary for counter-balance of Backhoe. **(Assembled, additional slip on weights available for even more front weight).**

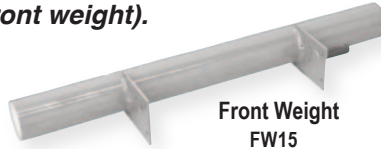

Front Weight FW15

BUCKET FORKS KIT - Four, 25" long, 19" high, 2-1/2" wide x 1/2" thick solid steel forks quickly mount to BK44 or BK45 Material Bucket with eight locking bolts. 350 lb. rated load. Requires BK44 or BK45 Material Bucket and drilling of holes in "bottom face" of bucket by customer.

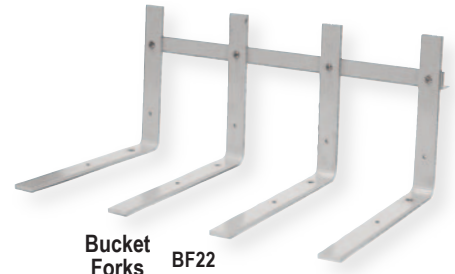

Bucket Forks BF22

MD196K & RS1000 Track Options & More

GROUSER TRACK SHOE KIT - Heavy-duty "U" shaped, 8" wide x 2" deep x 1/2" tall, all-steel shoes, provide the ultimate stiffness and strength to steel track allowing use in rocky conditions with the best possible traction. Comes complete with all fasteners. Factory assembly available on RS1000. **(Steel tracks only).**

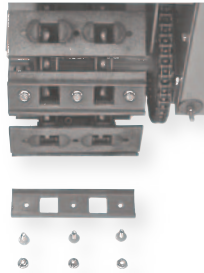

Grouser Shoe TS058

MUD / ICE SCRAPER KIT - Pair of dual "scraper arms" mount between front and rear track sprockets. When tractor is in motion, they continually remove rock chips, mud and snow build-up from between track sprockets. **(Steel tracks only).**

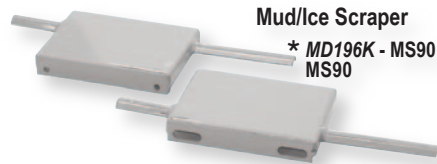

Mud/Ice Scraper * MD196K - MS90 MS90

RUBBER TRACK UPGRADE KIT - Contractor grade rubber tracks, will give you the Power & Traction you need, with the "Velvet Touch" of rubber! Tracks consist of a continuous steel core band and forged steel metal bars inside the rubber. Measures: 7" wide x 72mm pitch x 35 links. **(Assembled on RS1000).**



Rubber Track Upgrade RTU19

HOUR METER/TACH KIT - Hour meter & Tachometer kit gives added "peace of mind" for scheduled maintenance. Meter is mounted on the front of the dash within easy sight of the operator. **(Assembled, for RS1000 only).**



Hour/Tach Meter HM10

MD196K Rear Attachments

MANUAL REAR HITCH KIT - Standard-duty "sleeve hitch" rear lifting system. Has 2 "lift-assist" springs to aide in lifting attachments. 2 lbs. of lift handle force will raise 24lb. DR30

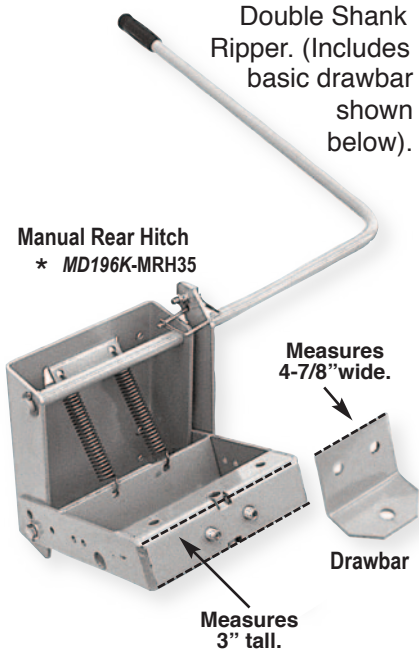

DOUBLE RIPPER KIT - Two 16" tall x 2" wide x 1/2" deep "hardened steel" ripping teeth mounted to heavy-duty steel channel. Great for loosening hard packed driveways and landscaping. Design allows to flip tooth for greater wear.



MANUAL WINCH KIT - Manual utility winch, 800 lb. pull capacity, 5/32" dia. x 25 ft. long cable with hook. (Requires LW228 Log Crane or mounting location provided by customer).

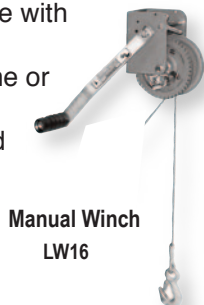

MD196K & RS1000 Rear Attachments

REAR DRAWBAR KIT - Basic pulling on a budget. Drawbar measures: 9-1/4" wide with 90° bend, can be mounted 5-1/2" or 10-1/2" above ground height. Has 3/4" hole for ball hitch. (Cannot be used while any rear attachment is mounted).



HITCH ADAPTER KIT - Class 2 trailer hitch mounts to Rear Hitch with two bolts. Tube ID measures 2", and allows use of dozens of rear attachments, such as: log carriers, garden carts, etc. (Does NOT include ball hitch).



LOG CRANE ADAPTER / DRAWBAR KIT - Required for use of LW228 Log Crane when a MRH35 or HRH35 Rear Hitch is mounted. Has 3/4" hole for ball hitch. (Can also be used alone when you need a drawbar and have a Rear Hitch mounted).



LOG CRANE KIT - Heavy-duty rear mounted crane. Great for pulling logs on a budget. Add LW16 Manual Winch (at left), or EW20 Electric Winch (at right). Has self-contained drawbar with 3/4" hole for ball hitch.



RS1000 Rear Attachments

HYDRO REAR HITCH KIT - All-hydraulic Rear Hitch allows operator to effortlessly hook-up and move logs, rear-mounted carriers, tillers, compact trailers, etc. (**Assembled, requires PP35 Power Pack, pictured on page 4. Includes basic drawbar shown below.**)

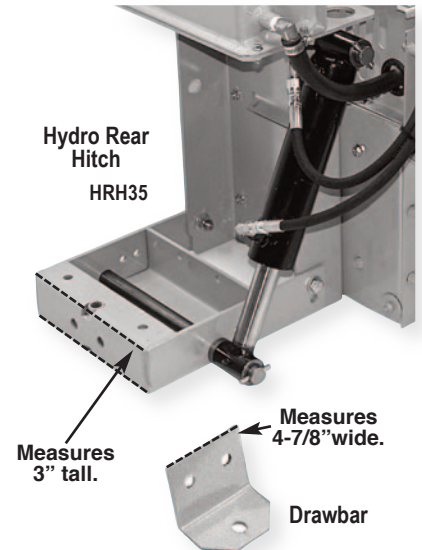

THREE SHANK RIPPER KIT - Three 16" tall x 2" wide x 1/2" deep "hardened steel" ripping teeth mounted to heavy-duty frame. Great for loosening hardpacked driveways and landscaping. Design allows to flip tooth for greater wear.



ELECTRIC WINCH KIT - 12V utility winch, 2,000 lb. pull capacity, 5/32" dia. x 50 ft. long cable with hook. Includes free-spooling clutch release. Operated with push button switches. (Requires LW228 Log Crane or mounting location provided by customer).

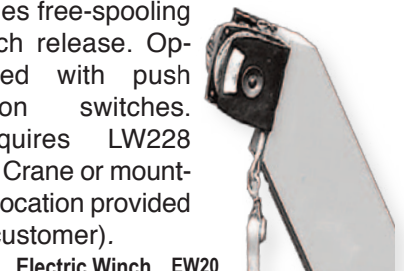

RS1000 Rear Attachments Continued

POWER PACK KIT - Hydraulic power system for operating hydro attachments. Includes: 3 bank valve, hydraulic oil tank, hoses, breather cap, pump, pulleys, belt & more. **(Assembled. See HFH15 Hydro Front Hitch & HRH35 Hydro Rear Hitch).**



Power Pack
PP35

FLOAT VALVE UPGRADE KIT - This upgrade allows your hydro front & rear hitch to "float" effortlessly above the ground. Great for backgrading, snow removal or floating a 3rd party rear attachment. **(Assembled. Factory upgrade only).**



Float Valve Upgrade FVS20

BALLAST BOX KIT - Weight box comes with both mounting brackets to use with the hydro rear hitch or angle mount kit. (For max loads, customer must provide weight or purchase weight from the factory).

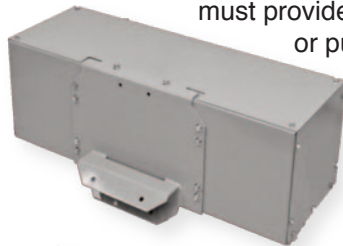

Ballast Box
BB60

BACKHOE KIT - 6 1/2" ft. digging depth backhoe, mounts easily to a set of AM39 Angle Mounts Brackets (bottom right), with just a few bolts. D1060UG utilizes (2) hydraulic stabilizers and (2) joystick wobble controls for all digging operations. Comes with fully rotatable and adjustable seat. **(Assembled on a secondary pallet).**

BACKHOE BUCKET KIT - Standard 12" wide Backhoe Bucket mounts directly to Backhoe dipper arm. Perfect for all around digging use (See below on backhoe).

Backhoe Bucket
B612

BACKHOE FROST / CHISEL TOOTH RIPPER KIT

- Heavy-Duty single tooth ripper mounts in place of Bucket... equipped with two types of replaceable teeth, see below:



Backhoe
Frost /
Chisel
Ripper
BR50

(#1) 16" tall x 2" wide x 1/2" deep, hardened steel ripping tooth for stone & frost picking & hardpan penetration to 18" (Shown above).

(#2) 17" tall x 1/2" wide x 2" deep, tooth allows root cutting to depths of 18" (Not shown).

ROCK / DEBIS THUMB KIT

- Rock "thumb" mounts to Backhoe "dipper arm" of Backhoe with two bolts. Great for grabbing brush, logs and rocks. Distance of Bucket "teeth" to Thumb is adjustable.

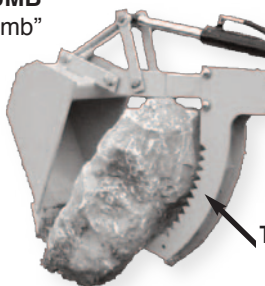

Rock
Thumb
RT24

ROLL-OVER PROTECTIVE STRUCTURE KIT - The MAGNATRAC'S low center of gravity and ground gripping traction are no substitute for this 80-3/4" tall safety structure. A must if intended to use the MAGNATRAC in a business.

Includes: roll-over structure, seat belt and mounting hardware. **(Assembled. Requires AM39 Angle Mounts).**

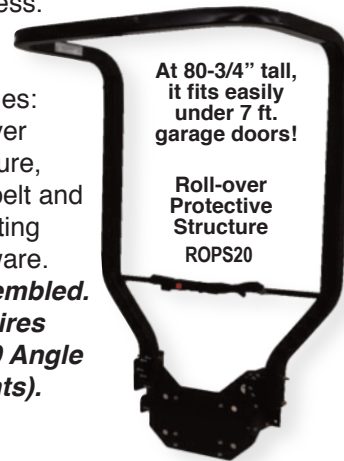

At 80-3/4" tall, it fits easily under 7 ft. garage doors!

Roll-over Protective Structure
ROPS20

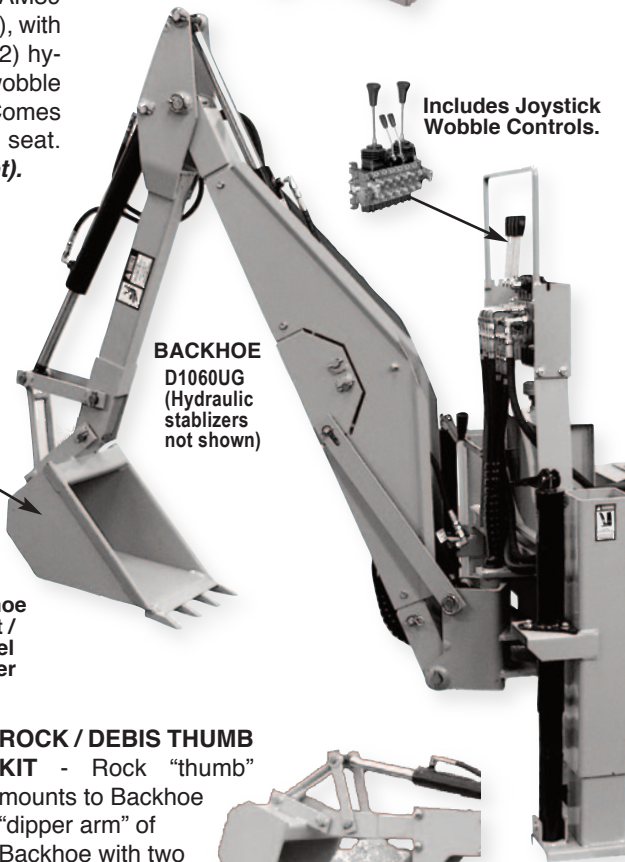

BACKHOE
D1060UG
(Hydraulic stabilizers not shown)

Includes Joystick Wobble Controls.

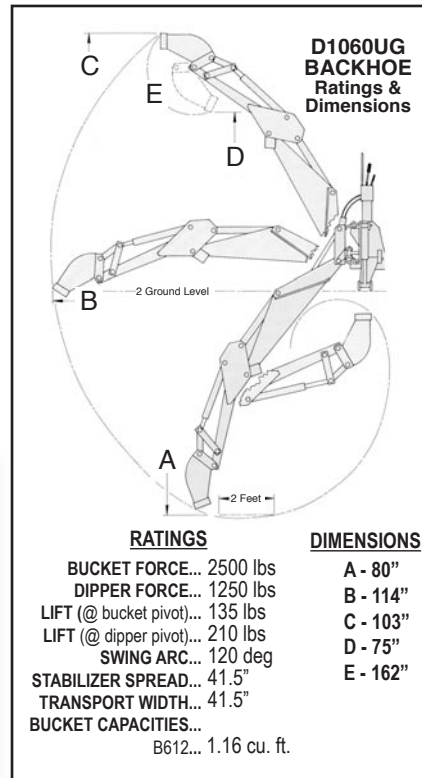

SAFETY NOTE: To "safely" counter-balance the Backhoe's weight, **FW15, HFH15,** at a minimum, the following front attachments should be installed: **HE47 and DB44.**

ANGLE MOUNT KIT - Two heavy-duty mounting brackets are the connection point for a ROPS, Backhoe or Ballast Box. **(Assembled).**

