

MINI-BEEP[®]

KITS & ACCESSORIES

ASSEMBLY MANUALS



C. F. Struck Corp. ● Box 307 Cedarburg, WI 53012 ● E-Mail: info@StruckCorp.com
Phone: (262) 377-3300 ● Web: www.Struck-Kit.com

KIT #MB311 Class 2 Rear Hitch

Parts List

3081AF Front Channel
 3081AR Rear Channel (with 1463B Tube)

5/16-18x3/4 Cap Screw, Spinloc (8)
 5/16-18 Nut, Spinloc (8)

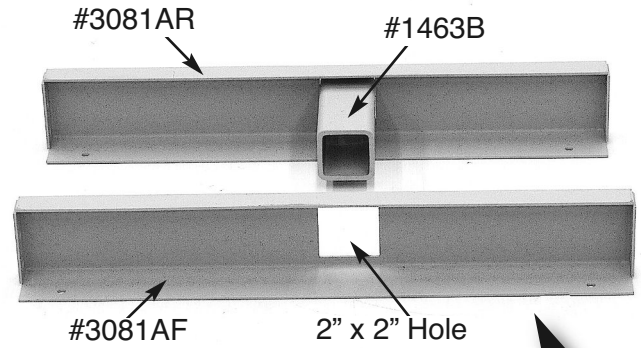

Assembly

#3081AR & #3081AF Assembly

STEP 1. On *underside rear* of Body, remove the four 5/16 Nuts securing the #3080R & #3080L Right & Left Angles to rear end of #3001 Floor (photo at right).

NOTE: Try not to break the “silicone seal” of the four 5/16 Cap Screws in the Body as you remove the 5/16 Nuts. It’s suggested to “re-silicone seal” each of the four 5/16 Cap Screws and Nuts as you make your final assembly.

STEP 2. Insert #1463B Tube of #3081AR Rear Channel into mating 2” x 2” hole in #3081AF Front Channel (photo above).

STEP 3. Take this #3081AF & #3081AR Front & Rear Channels Assembly and slip it between the *vertical sides* of the #3080R & #3080L Right & Left Angles and over the four 5/16 Cap Screws you revealed in STEP 1 above... leave loose! (See photo at right.)

STEP 4. Locate the 5/16” holes in *vertical sides* of #3080R & #3080L Right & Left Angles with mating 5/16” holes in *right & left ends* of #3081AF & #3081AR Front & Rear Channels.

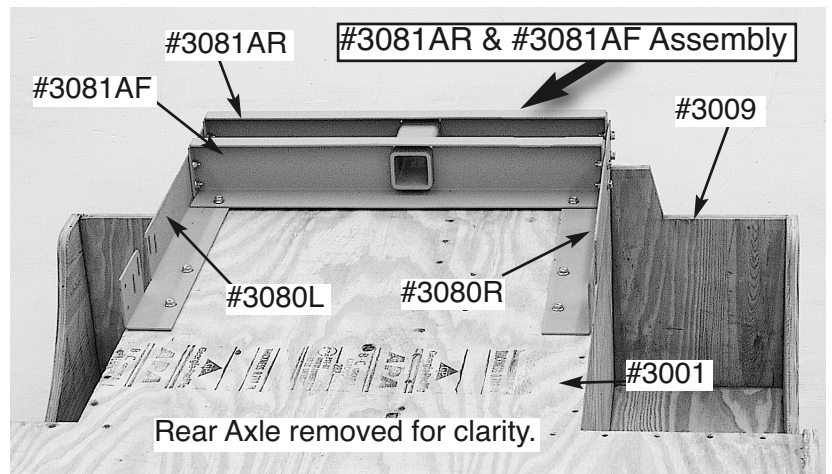
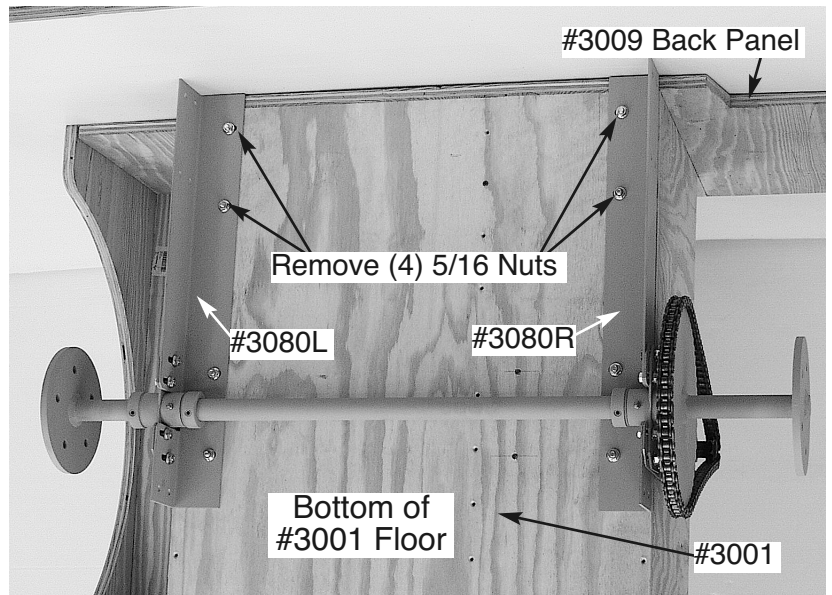

STEP 5. Tighten all (12) twelve 5/16 Cap Screws assembled. Check that all Cap Screws that *pierce* the Body are “silicone sealed” and watertight!

NOTE: Any Attachment that you use with this Class 2 Hitch must be included in calculating the MINI-BEEP’s recommended Payload Weight. In addition, you can add a counter-balance to “rear end loads” with weights (plastic bags of 30-40 lbs. of sand & gravel) placed in the cavity between *rear face* of #3002 Grill and *front face* of #3059 Panel... you should be able to get two to three bags in this location.

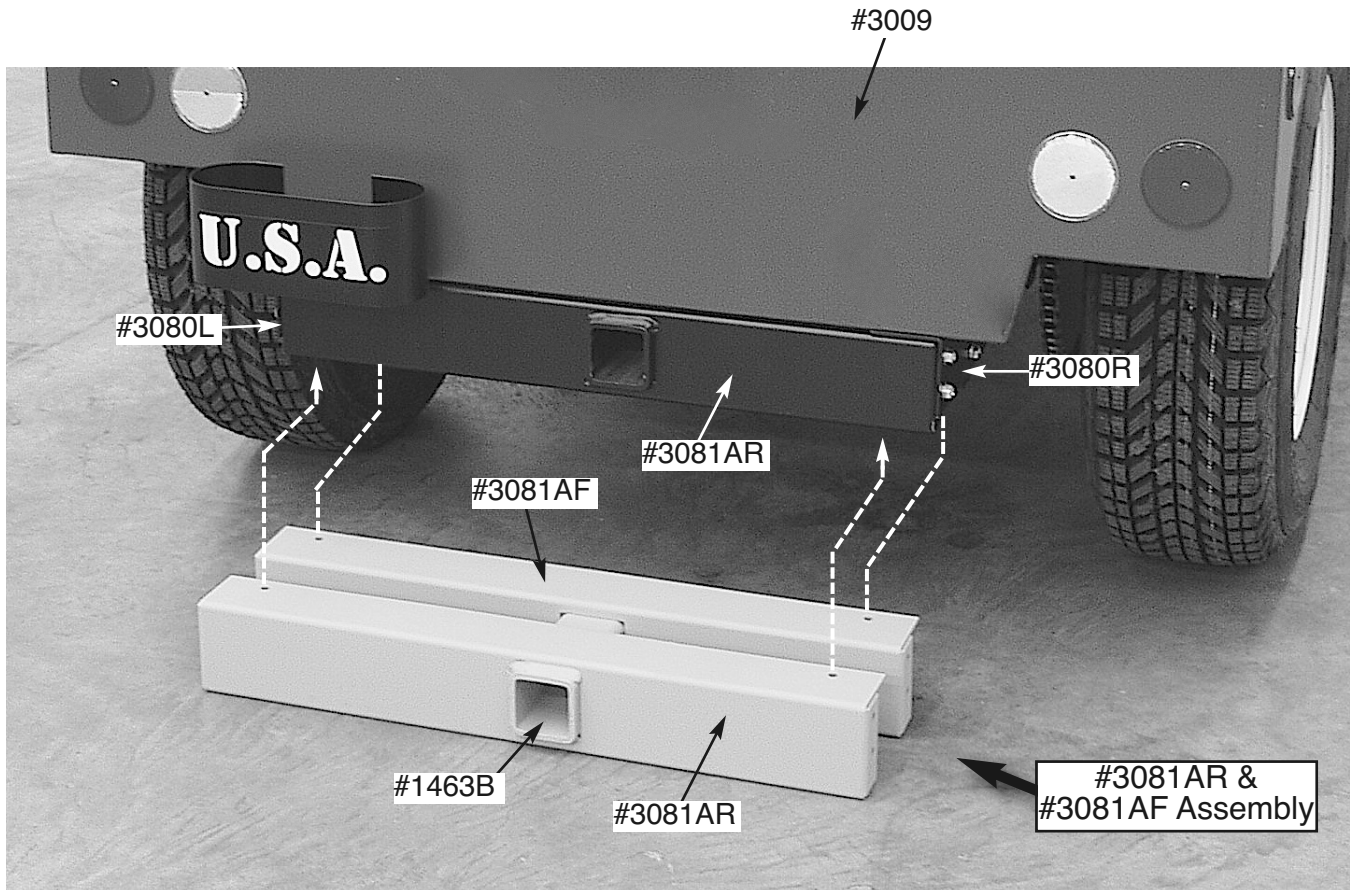

KIT #MB312 Spare Tire Bracket

Parts List

3074	Spare Tire Bracket
1/4-20x1-1/4	Carriage Bolt (4)
1/4-20	Nut, Spinloc (4)
1/2-20x1	Lug Bolt, conical seat (2)

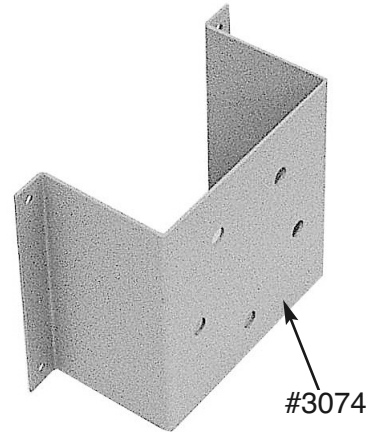

Assembly

STEP 1. Locate #3074 Bracket on *back face* of #3009 Back Panel per “photo-drawing” below. Using the Bracket as a template, mark the location of the four 1/4” holes on Rear Wall. Remove Bracket and 1/4” Drill the four holes.

STEP 2. From *inside* Body, insert a 1/4-20 Carriage Bolt into each of the four 1/4” drilled holes. *Outside* Body, slip #3074 Bracket over protruding Carriage Bolts and secure with 1/4-20 Nuts.

STEP 3. Locate the two 1/2” threaded holes in Bracket. Slip Tire (on rim) over Bracket (valve stem out) and secure with two Lug Bolts using threaded holes located in STEP above.



KIT #MB313 Float Box Hitch

Parts List

3079	Float Box Hitch Assembly
3079A	Hitch Tube
3079B	Support Tube
3079C	Angle
5/16-18x1-1/4	Carriage Bolt (8)
5/16-18	Nut, Spinloc (8)

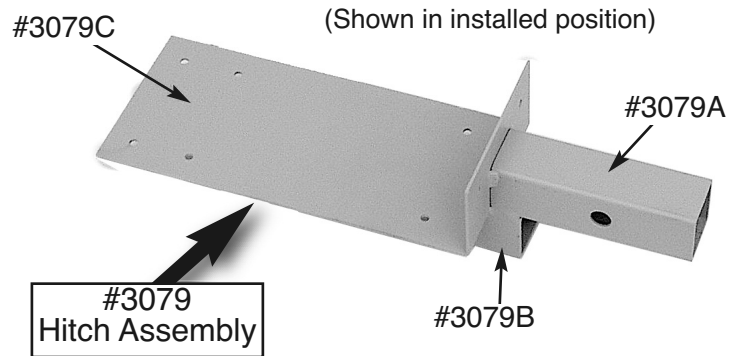

Customer Furnished Parts

3082	Bottom Panel	12-1/2" x 46-1/2" x 3/4"
3083	Side Panel	11-1/2" x 46-1/2" x 3/4" (2)
3084	End Panel	11-1/2" x 14 x 3/4" (2)
3087	Cover Panel	12-1/4" x 46-1/4" x 3/4"
3134	Strip	6" x 1" x 3/4" (4)

(XPS) Rigid Insulation	Drive Screws
Waterproof Glue	Countersink
Epoxy Filler	Wood Filler
Silicone Sealer	Hitch Pin, 5/8" dia..
Tie Down Straps (2)	

NOTE: Use the same procedures, tools and supplies from the construction of your MINI-BEEP Body. Check final placement of Screws so you don't collide one into another!

Assembly

STEP 1. Using the dimensions shown in "photo-drawing" (below), cut the #3082, #3083, #3084 and #3087 Panels out of "plywood remnants" from your Body construction or from new plywood per "plywood specifications" in your Plans/Assembly Manual. Patch all panel voids & blemishes with wood filler... when dry, sand blemishes.

STEP 2. Assemble your five "box" Panels to form the box shown in "photo-drawing" below... use clamps to hold Panel positions. Layout your 3/32" pilot holes (for Drive Screws) keeping them 3/8" from *outside* edges and space them approximately 3" apart... drill all pilot holes approximately 1/2" deep then follow with the "countersink" you used in your Body construction.

STEP 3. Unclamp your "box". Reassemble, this time using Glue and Drive Screws... let dry, then remove all clamps. Do finish "woodworking" now... rout edges, sand, epoxy screw holes, etc. Completely paint and finish your Float Box and all it's components.

STEP 4. Locate your #3079 Hitch Assembly such that the “angle” of its #3079C Angle “cups” the *forward* #3083 Side Panel and #3082 Bottom Panel and is squared and centered *left to right*... check “photo-drawing” (below).

STEP 5. Mark the eight 5/16” holes in the #3079C angle on the Side & Bottom panels. 5/16” drill all eight holes. From *inside* Box, insert 5/16-18 Carriage Bolts into each hole and secure on *outside* with 5/16-18 Nuts. [Silicone seal these Bolts as you assemble].

STEP 6. Slip #3079A Hitch Tube into #1463B Tube of MB311 Rear Hitch. Align 5/8” holes in Hitch Tube with mating holes in #1463B Tube... secure with standard 5/8” dia.. Hitch Pin and “hairpin”.

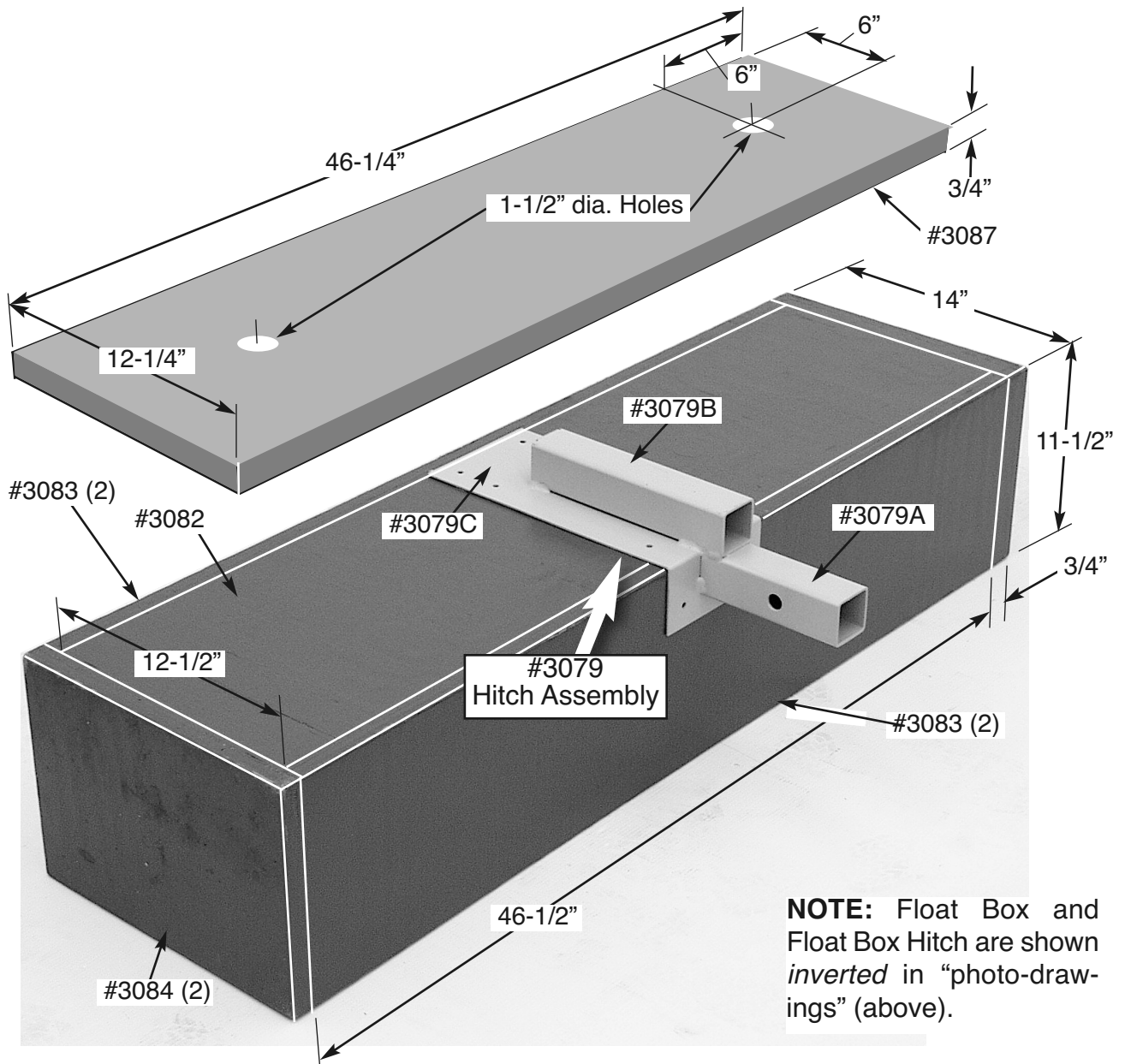

STEP 7. Using (XPS) Rigid Foam Insulation, cut panels 46" long x 12" wide until you have a "stack" 10" high. Load your Float Box and close with #3087 Cover.

STEP 6. Slip #3079A Hitch Tube into #1463B Tube in MB311 Rear Hitch. Align 5/8" holes in Hitch Tube with mating holes in #1463B Tube... secure with standard 5/8" dia. Hitch Pin and "lock" hairpin.

NOTE: THERE ARE TWO METHODS TO SECURE THE #3087 COVER PANEL.

METHOD #1.

Add more XPS "panels" to your Float Box (if necessary) so that the Cover is located *vertically* where it's shown in photo (below). Secure with two standard "tie down" Straps located about 12" from each end of Box. Make sure your straps are secure.

This method allows you to quickly remove the straps to unload your Float Box and use it as a "cargo carrier" when you are not planning to enter water more than 12" deep.

NOTE: Float Box and Float Box Hitch are shown in *operating* position in "photo-drawing" (below).

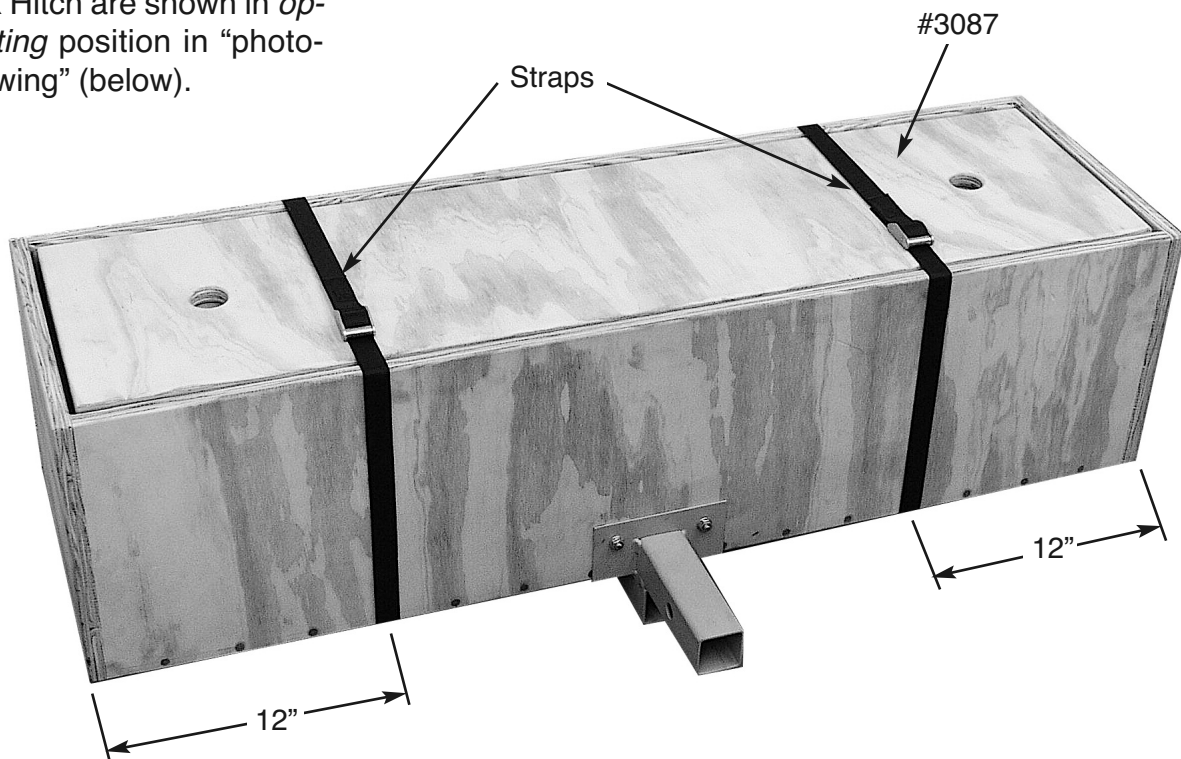

METHOD #2.

With #3087 Cover in place, check that you have approximately 1" (+/-) of *inside* wall "exposed"... if not, adjust XPS Panels accordingly. When satisfied, cut four (4) #3134 Strips of 1" wide by 3/4" thick material (plywood or clear pine) 6" long. "Center" two 3/32" pilot holes 3" apart on each Strip per photo-drawing below. With Cover in place, install Strips per photo-drawing (below) and secure each with two (2) 1-1/4" Drive Screws.

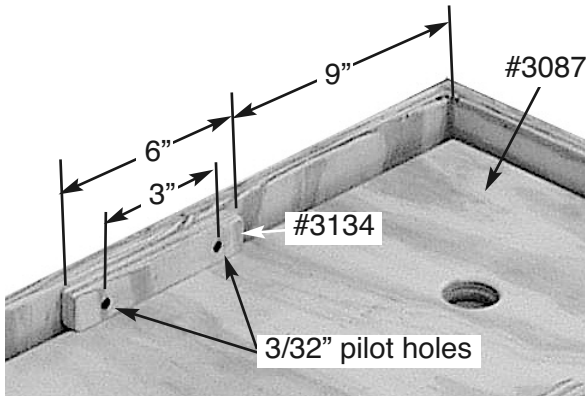

This Method is more permanent and doesn't require constant monitoring of the tightness of the Straps as used in METHOD #1 (above).

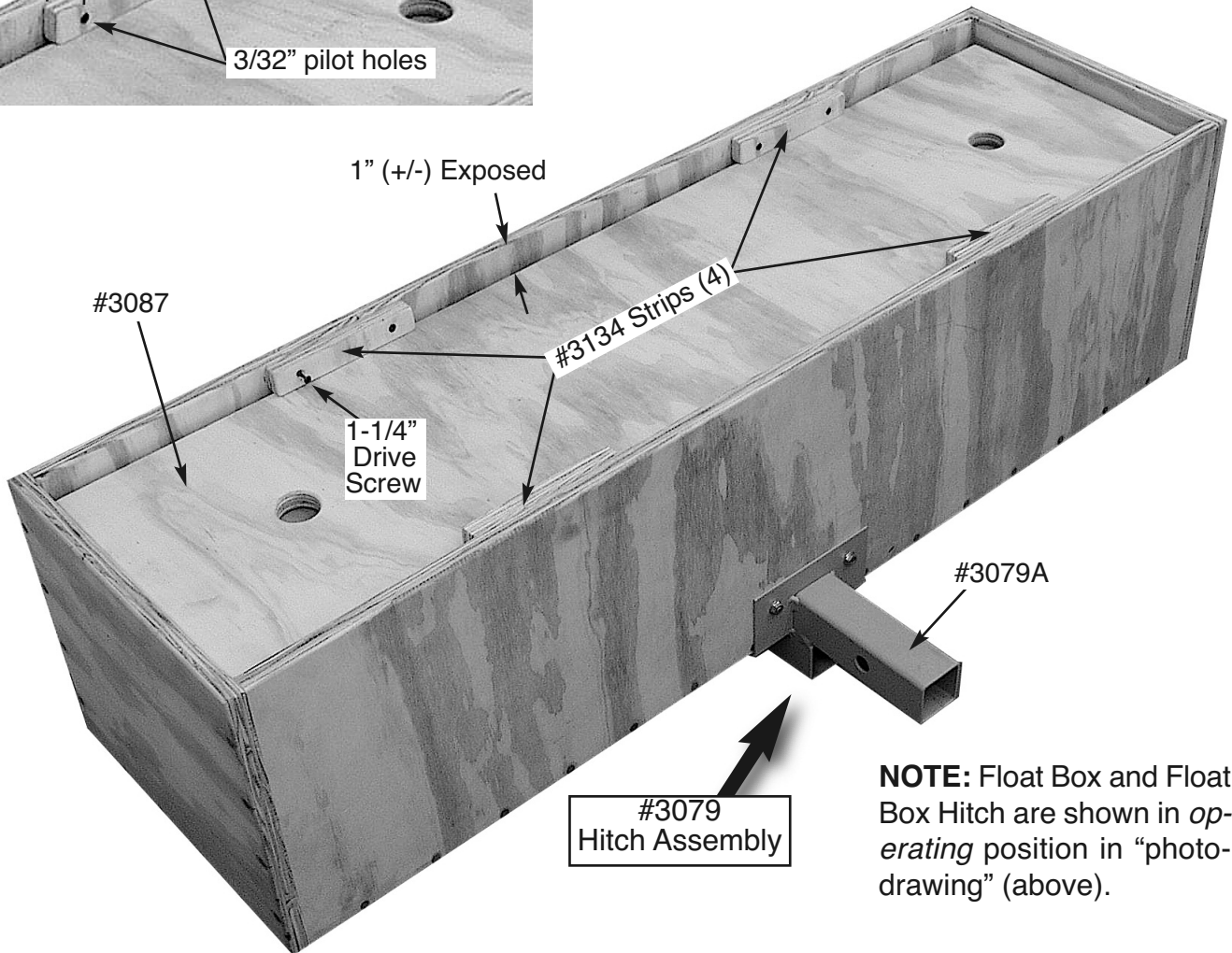

Your Float Box provides necessary flotation qualities for safety and must always be used when driving in water over 12" deep!

KIT #MB314 Rear Winch Mount

Parts List

3086	Rear Winch Mount Assembly
3086A	Plate
3086B	Tube

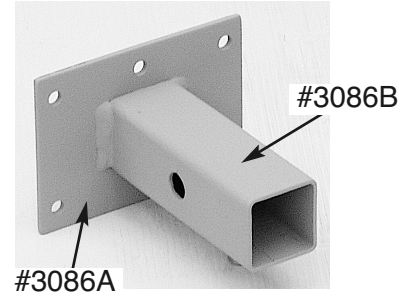

The #MB314 Rear Winch Mount is of simple, though rugged construction. It provides the MINI-BEEP builder with a “base” to mount a variety of ATV Winches for rescue and lifting requirements.

In addition, the MINI-BEEP builder may also use the Mount as a secure “mounting point” for items he would like to design for himself.

KIT #MB315 Trolling Motor Mount

Parts List

3089	Angle Assembly	1/4-20x1-1/4	Carriage Bolt (4)
3089A	Angle (2)	1/4-20x2	Carriage Bolt (4)
3089B	Plate	1/4-20	Nut, Spinloc (8)

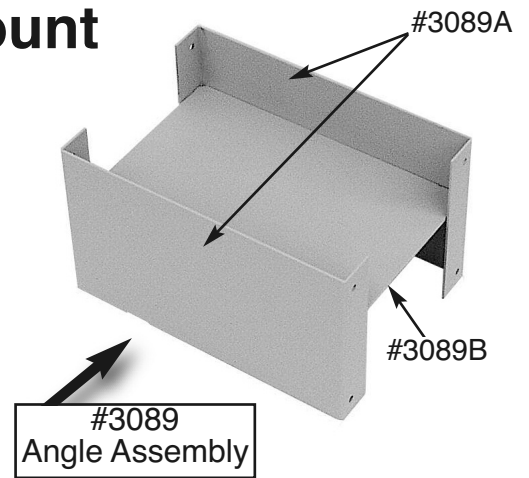

Assembly

STEP 1. Locate #3089 Angle Assembly on *back face* of #3009 Back Panel per “photo-drawing” below. Using the Angle Assembly as a template, mark the location of the four 1/4” holes on Rear Wall. Remove Angle Assembly and 1/4” Drill these four holes.

STEP 2. From *inside* Body, insert a 1/4-20x1-1/4” Carriage Bolt into each of the four 1/4” drilled holes. *Outside* Body, slip #3089 Angle Assembly over “protruding” Carriage Bolts and secure with 1/4-20 Nuts.

STEP 3. Cut out two (2) 3/4” thick “exterior grade” plywood panels 9-1/4” long by 7-1/2” high. Glue & “sandwich” them together. Align and square them with the remaining ends of #3089 Angle Assembly. Locate the remaining four (4) 1/4” holes on the “sandwiched” panels and 1/4” drill the holes.

STEP 4. From *outside*, Insert 1/4-20x2 Carriage Bolts into the four 1/4” holes. *Inside* Angle Assembly secure with 1/4-20 Nuts.

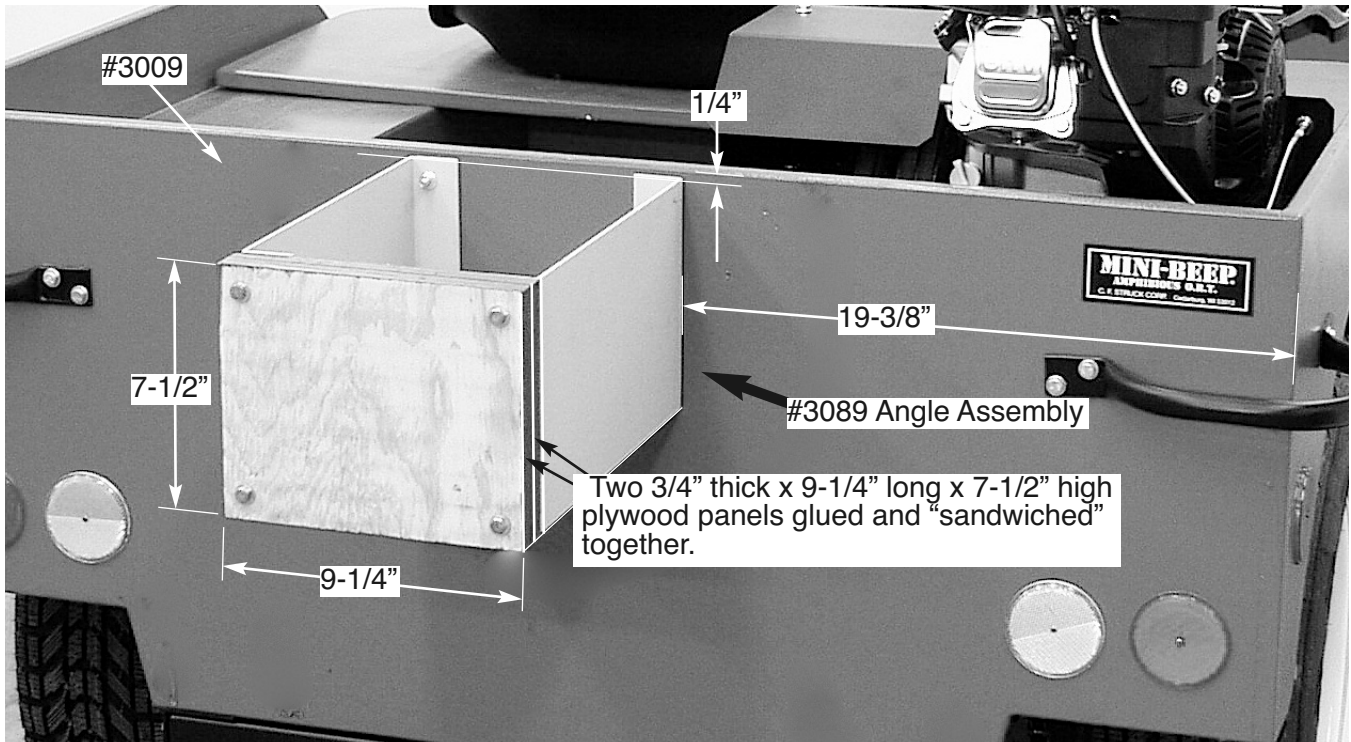

KIT #MB316 Detail Package

Parts List

446	Headlight (2)	1/4-20x1-1/4	Cap Screw (16)
3053	Mount, headlight (2)	1/4-20	Nut, Spinloc (16)
3067	Corner Handle (2)	1/4 ID	Washer (16)
3068	Surface Handle (3)	5/16-18x2	Cap Screw (2)
3111	Screw, Pan Hd, #10x3/4 (8)	5/16-18	Nut, Spinloc (2)
3129	Reflector, white, with installation nail (2)	5/16	Washer (2)
3130	Reflector, red, with installation nail (4)	#8	Washer (8)
3131	Labels #1, sheet, 19" x 27"		
3132	Labels #2, sheet, 19" x 27"		
3133	Pedal Pad (3)		

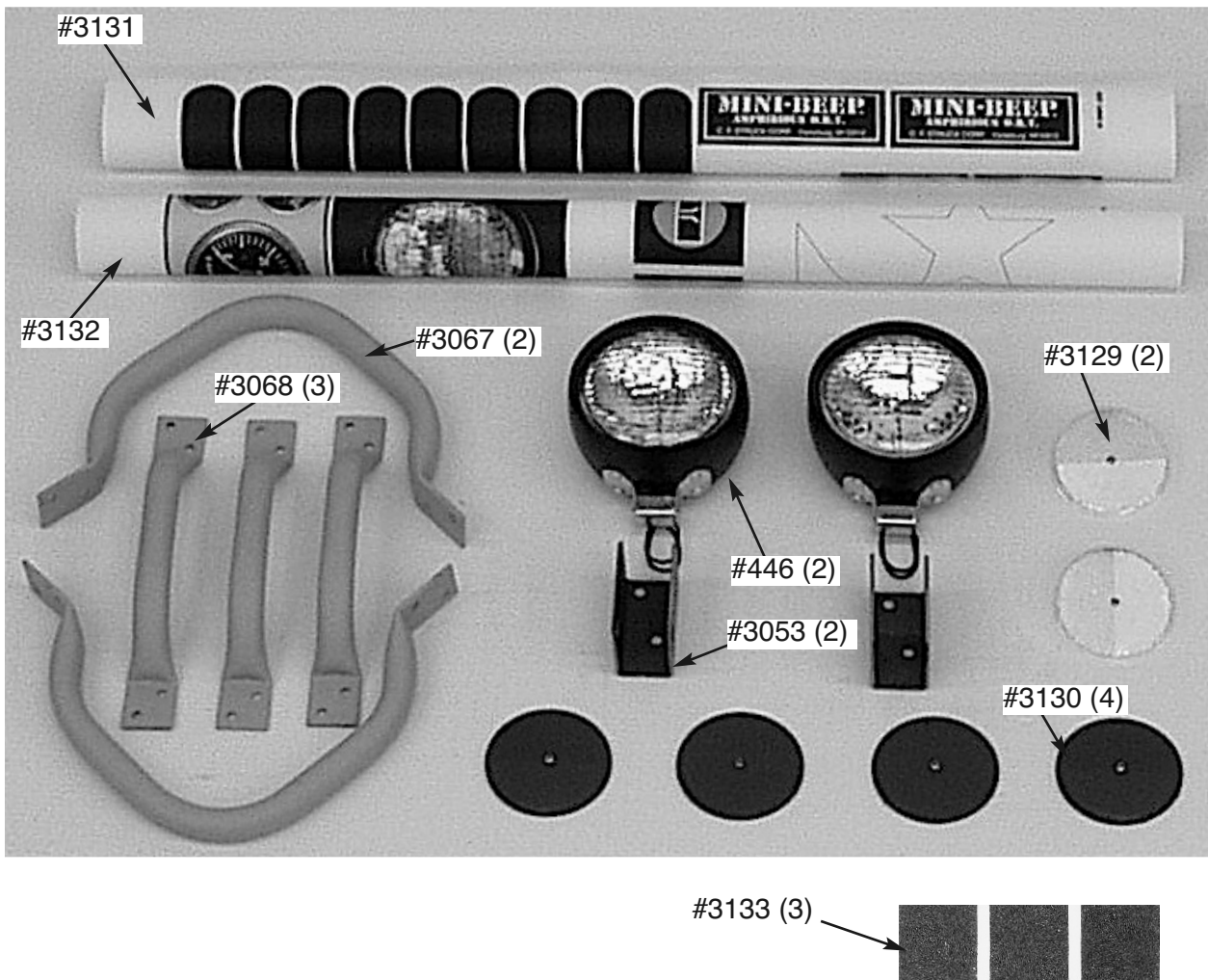

NOTE: Use the following pages G7 & G8 to identify Labels referred to in the following Assembly STEPS.

4.4.11

MINI-BEEP
AMPHIBIOUS ORT™
 C. F. STRUCK CORP. Cedarburg, WI 53012
 Web: www.Mini-BEEP.com
G7B (2)

MINI-BEEP
AMPHIBIOUS ORT™
 C. F. STRUCK CORP. Cedarburg, WI 53012
 Web: www.Mini-BEEP.com

MINI-BEEP®
AMPHIBIOUS ORT™ **G7C (2)**

MINI-BEEP®
AMPHIBIOUS ORT™

Labels #1
 4.11.11

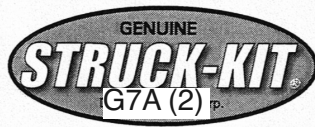

CAUTION! **G7D**

1. Never use or consume alcohol, drugs or any other substance that may effect your coordination, judgement or ability to safely operate this vehicle!
2. Always abide by all Coast Guard regulations and local & state laws, regulations, ordinances, and rules concerning boating and off-road vehicle safety.
3. When traveling in water, the wearing of a personal flotation device (PFD) is strongly recommended. Check with local authorities for current regulations. Attach Tether Switch to operator (if installed).
4. Properly "foam loaded" MB313 Float Box **must** be in place for water travel over 12 inches deep.
5. Always stay seated when MINI-BEEP is in operation.
6. Never allow minors (under 16 years old) to use this MINI-BEEP without adult supervision.

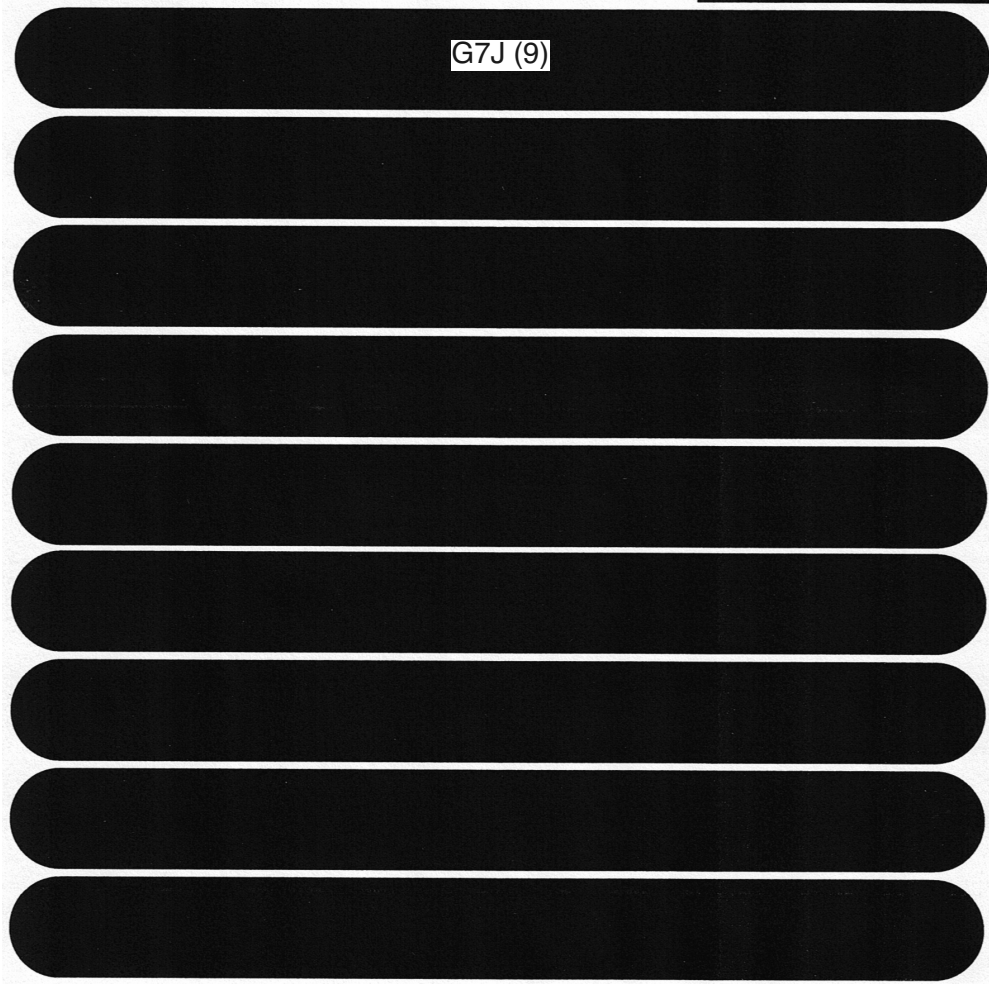

G7J (9)

FORWARD **G7E**

LOCK **G7H**

REVERSE **G7F**

BRAKE **G7G**

WIBA80 **G7I**

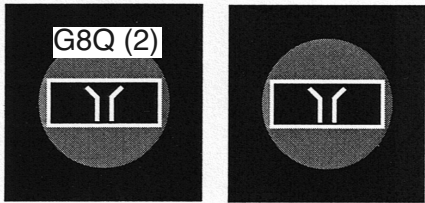
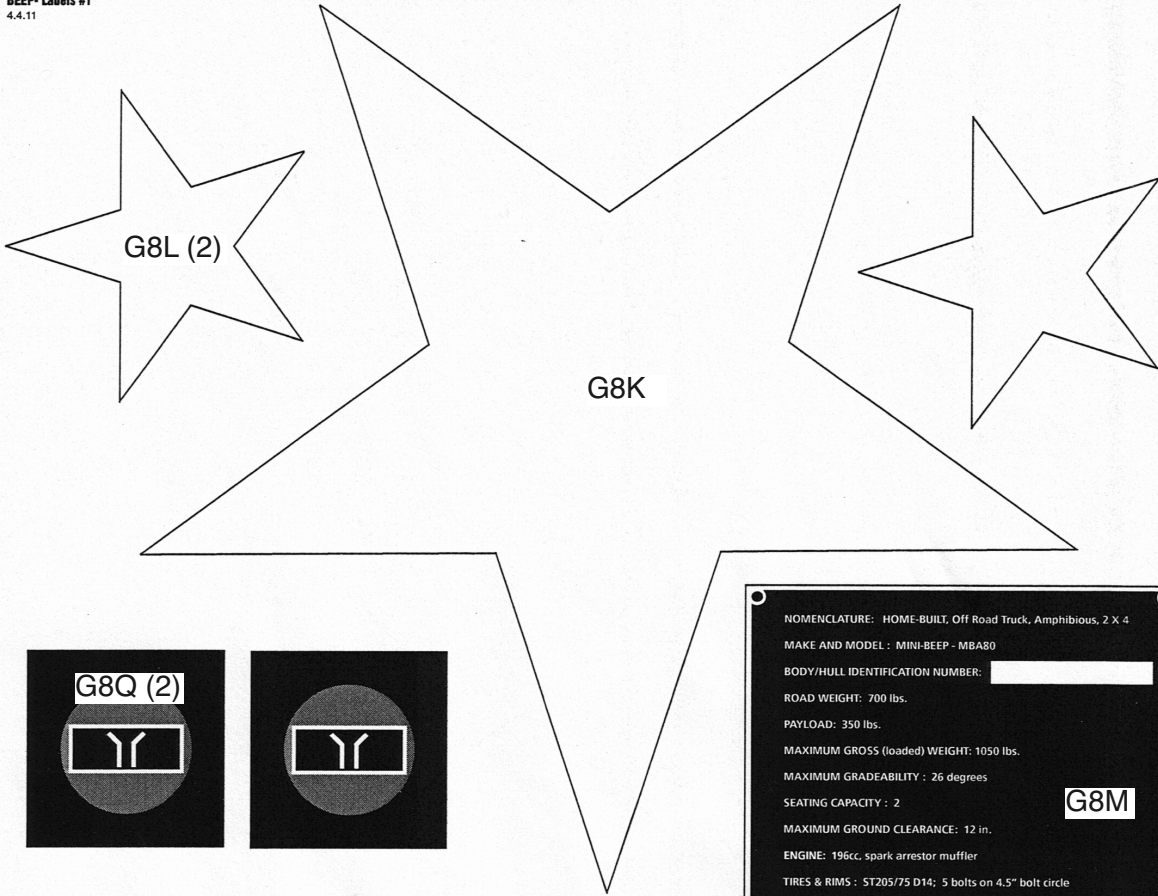

NOMENCLATURE: HOME-BUILT, Off Road Truck, Amphibious, 2 X 4
MAKE AND MODEL: MINI-BEEP - MBAB0
BODY/HULL IDENTIFICATION NUMBER: _____
ROAD WEIGHT: 700 lbs.
PAYLOAD: 350 lbs.
MAXIMUM GROSS (loaded) WEIGHT: 1050 lbs.
MAXIMUM GRADEABILITY: 26 degrees
SEATING CAPACITY: 2
MAXIMUM GROUND CLEARANCE: 12 in.
ENGINE: 196cc, spark arrestor muffler
TIRES & RIMS: ST205/75 D14; 5 bolts on 4.5" bolt circle
TOP SPEED: 10 MPH

G8M

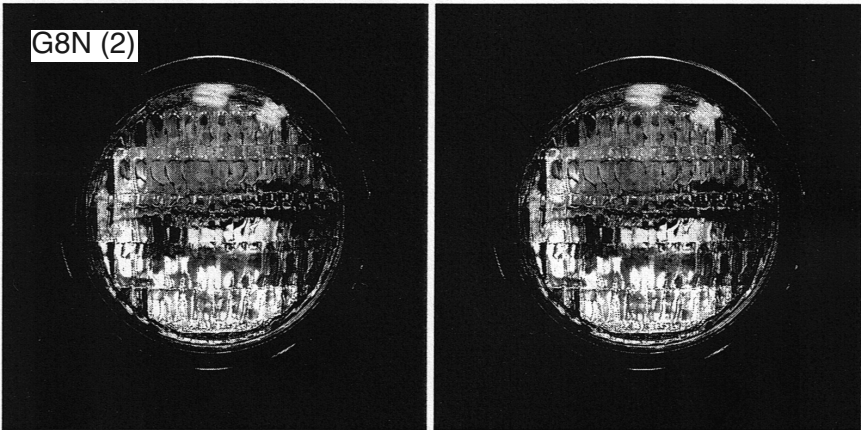

Labels #2
4.11.11

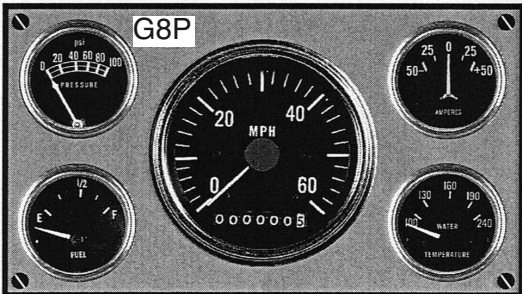

Labels, Reflectors, Pedal Pads & Handles Assembly

Labels: The following “photo-drawings” illustrate *suggested* locations for the Labels in your MB316 Detail Package. The builder may deviate from these locations based on personal preference.

Reflectors, Handles & Pedal Pads: The following “photo-drawings” illustrate *exact* locations for Reflectors and Corner & Surface Handles. **NOTE:** The “builder” may deviate from any of these instructions; they are provided as a guide to help “steer clear” of areas that may cause Body

STEP 1. Reflectors: Layout the center points of the #3129 White & #3130 Red Reflectors per “photo-drawing” below. Secure each Reflector in position with nail provided... pound each nail with care to avoid cracking the Reflector.

STEP 2. Handles: Locate #3067 & #3068 Handles on Body (and inside Dash above #G8M label) per “photo-drawing” below. Mark center of 1/4” holes of each Handle. Drill four (4) 3/32” pilot holes 1/2” deep into *inside face* of Dash above #G8M label. Secure #3068 Handle with four #3111 Screws and #8 Washers.

Next, 1/4” drill the marked position of each of the remaining Handles on Body. Mount Handles using 1/4” Washer over end of 1/4-20x1-1/4 Cap Screws and insert into aligned 1/4” holes of Body and Handles... secure *inside* with 1/4-20 Nuts.

STEP 3. Pedal Pads: Locate the #3133 Pedal Pads over “ends” of Pedals #3024A, #3025A and #3030A per “photo-drawing” (next page). Center each Pad *left to right* and over the “bend” in each Pedal’s end.

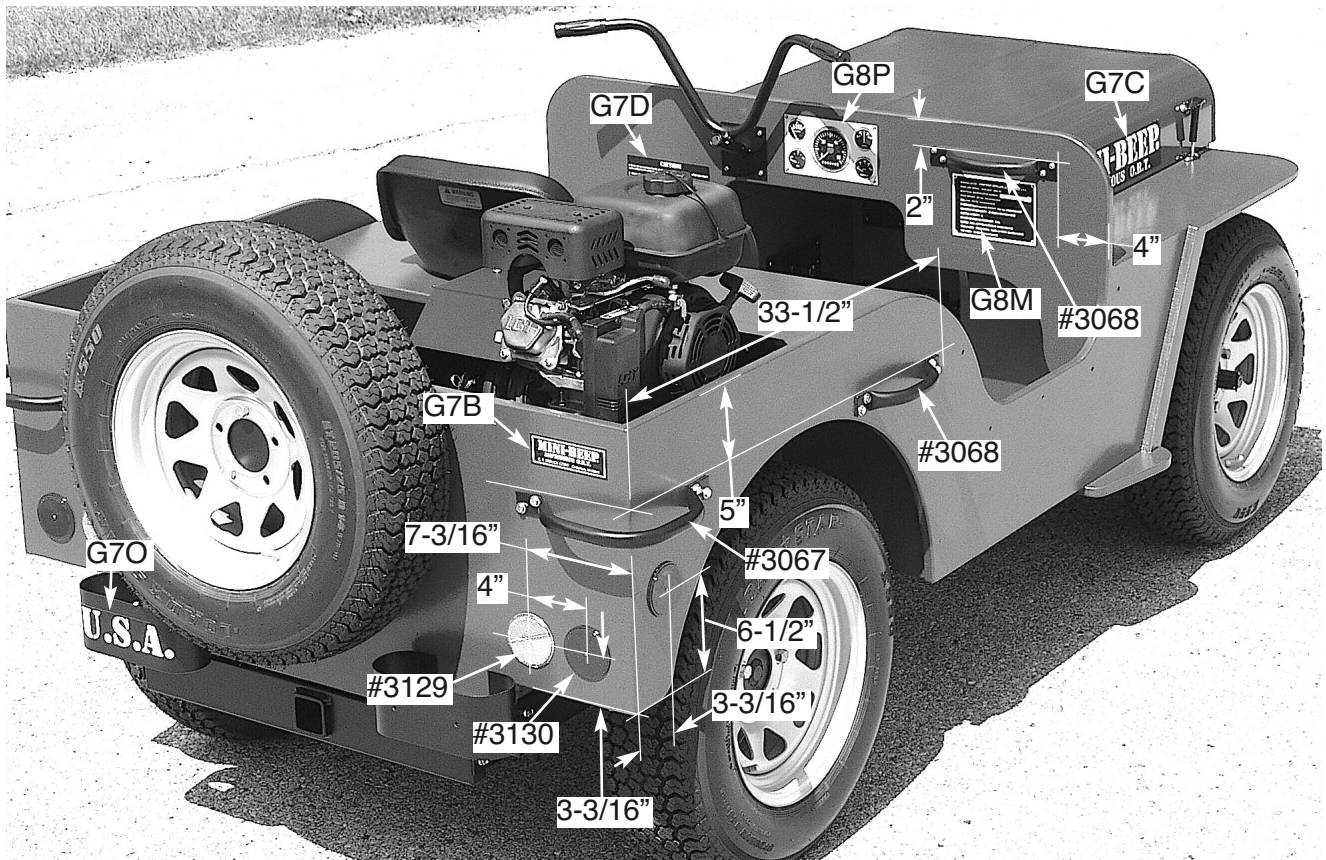

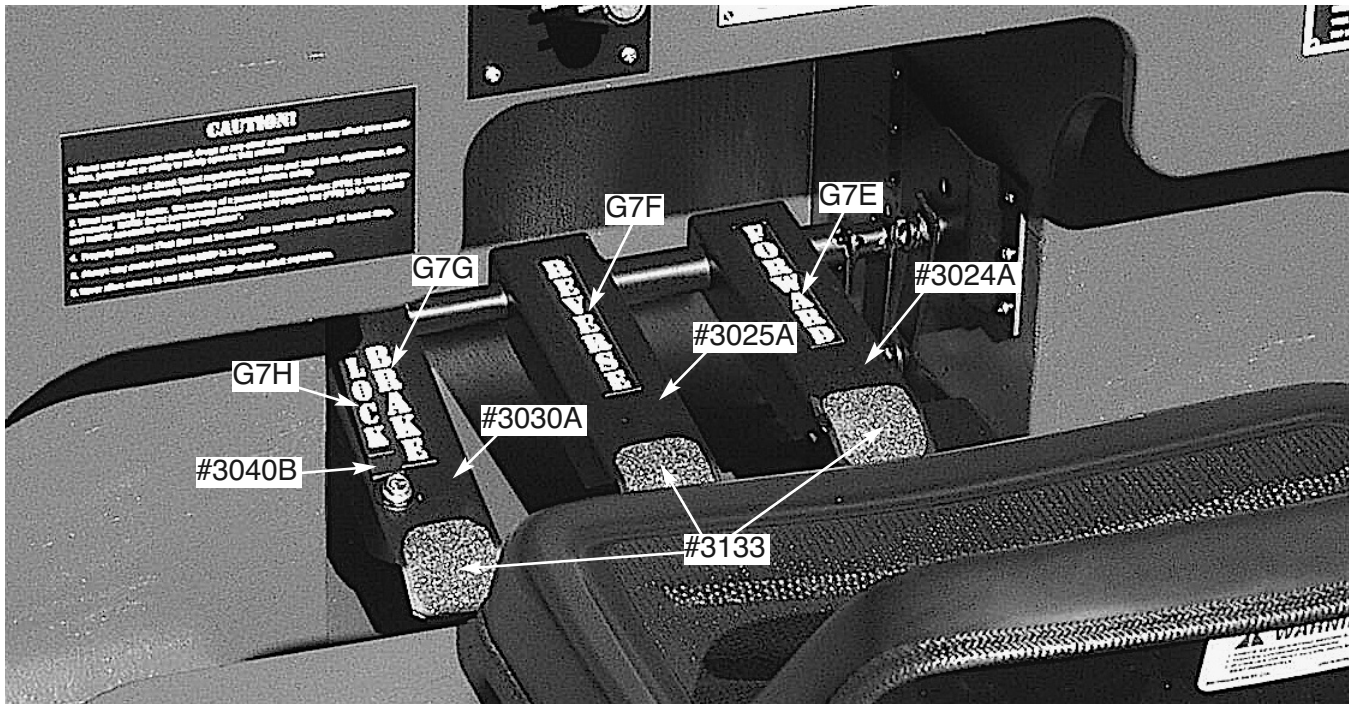

Grill Ribs Assembly

STEP 1. Using a scissors (or preferably a razor knife and steel straight edge) cut out all (9) #G7J Grill Ribs using just their “square” dimensions (1-1/2” x 14-1/2”)... don’t round corners. Once all 9 are cut out, patiently round each corner with a scissors.

STEP 2. Using a sharp, soft pencil, layout the pattern of the 9 Grill Ribs on the front face of the #3002 Grill as shown in “photo-drawing” below. Take your time and make light “tick marks” that can be easily erased on completion.

STEP 3. Making sure your Grill surface is dry and “grease free” (it should have it’s finish coat of paint). Start to apply your Grill Ribs following your pencil “tick marks” as a guide. **NOTE:** Don’t pull on your Ribs as they will stretch and make align more difficult.

STEP 4. When you have completed your Rib installation, place a sheet of paper over each Rib and rub it firmly to permanently affix it into position.

TIP: It’s a good idea to take scraps of unused portions of your Label Sheets and practice an “application technique” before actually applying your Ribs.



Headlight Assembly

STEP 1. Locate a #3053 Mount per the dimensions shown in “photo drawing” below on left and right *inside* face of #3002 Grill. Locate the two 3/16” holes of each #3053 Mount on the Grill.

STEP 2. Remove both Mounts and 3/32” drill all four “located” holes 1/2” Deep in Grill. Relocate both mounts over these holes and secure with #3111 Screws & #8 Washers... tighten.

STEP 3. Insert the “bracket” at the base of each Headlight between the “ears” of its respective #3053 Mount on left & right side. Line up *holes* in “bracket” with *slots* in Mount. Slip a 5/16 Washer over end of each Cap Screw and slip into “aligned” slots & holes of each Bracket & Mount. Secure with 5/16 Nut. Align each Headlight so that it is “square” in its mating hole in Grill... tighten!

NOTE: Final wiring of the lights should be supervised by a competent electrician.

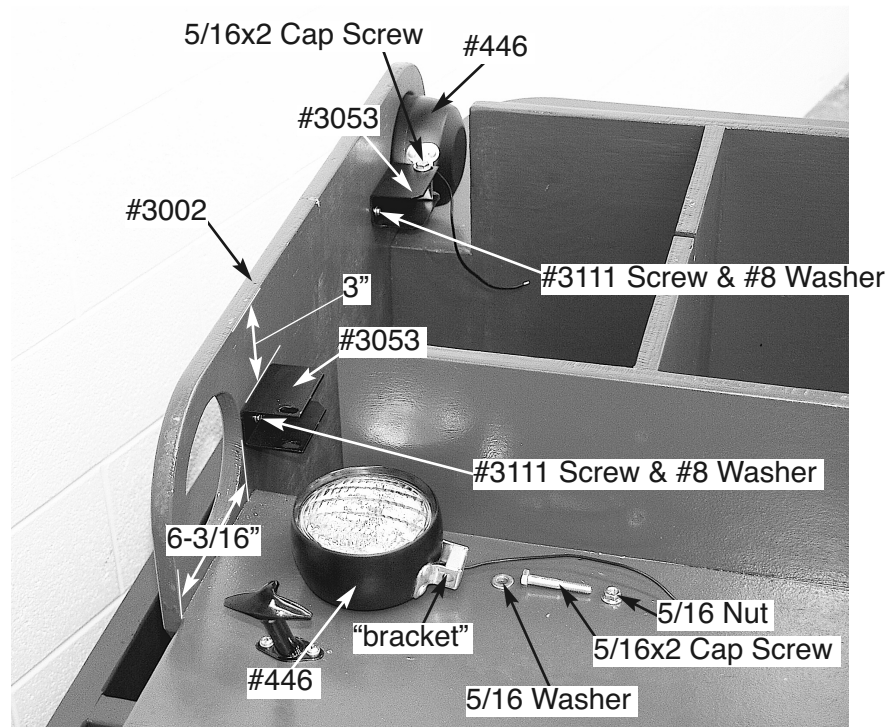

KIT #MB317 Cargo Box Hitch

Parts List

3093 Cargo Box Hitch Assembly
 3093A Plate
 3093B Tube

5/16-18x1-1/4 Carriage Bolt (4)
 5/16-18 Nut, Spinloc (4)

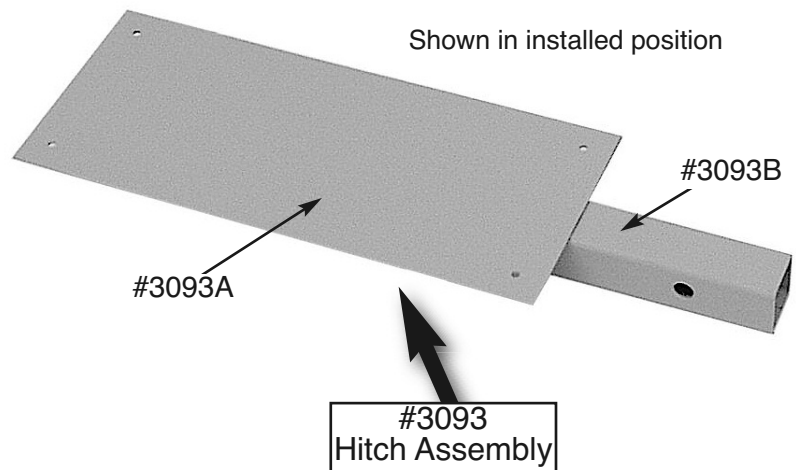

Customer Furnished Parts

3090	Bottom Panel	48" x 21" x 3/4"
3091	End Panel	21" x 5-1/4 x 3/4" (2)
3092	Side Panel	46-1/2" x 5-1/4" x 3/4" (2)

Drive Screws
 Waterproof Glue
 Countersink
 Epoxy Filler
 Wood Filler
 Silicone Sealer
 Hitch Pin, 5/8" dia..

NOTE: Use the same procedures, tools and supplies from the construction of your MINI-BEEP Body. Check final placement of Screws so you don't collide one into another!

Assembly

STEP 1. Using the dimensions shown in "photo-drawing" below, cut the #3090, #3091 and #3092 Panels out of "plywood remnants" from your Body construction or from new plywood per specifications in your Plans/Assembly Manual. Patch all panel voids & blemishes with wood filler... when dry, sand blemishes.

STEP 2. Assemble your five Panels to form a "box" as shown in "photo-drawing" below... use clamps to hold Panel positions. Layout your 3/32" pilot holes (for Drive Screws) keeping them 3/8" from *outside* edges and space them approximately 3" apart... drill all pilot holes approximately 1/2" deep then follow with the "countersink" you used in your Body construction.

STEP 3. Unclamp your “box”. Reassemble, this time using Glue and Drive Screws... let dry, then remove all clamps. Do your finish “woodworking at this time... routing edges, sanding blemishes, epoxying screw holes, etc. At this time completely paint and finish your Cargo Box.

STEP 4. Locate your #3093 Cargo Box Hitch Assembly such that its #3093A Plate is centered and squared “front to rear” and “left to right”... check “photo-drawing” below.

STEP 5. Locate the four holes in the #3093A Plate on #3090 Bottom Panel. 5/16” drill all four holes. From inside Box, insert 5/16-18x1-1/4 Carriage Bolts into each hole and secure on *outside* with 5/16-18 Nuts. [Silicone seal these Bolts as you assemble].

STEP 6. Slip #3093B Hitch Tube into #1463B Tube in MB311 Rear Hitch. Align 5/8” holes in Hitch Tube with mating holes in #1463B Tube... secure with standard 5/8” dia.. Hitch Pin and “lock” hairpin.

NOTE: When loading your new Cargo Box, be aware of the final *payload weight* of your MINI-BEEP with this added weight from a “loaded” Cargo Box... this *payload weight* should not exceed 350 lbs. [Check page E8 “Specifications & Recommendations” section of your Plans/Assembly Manual for explanation]

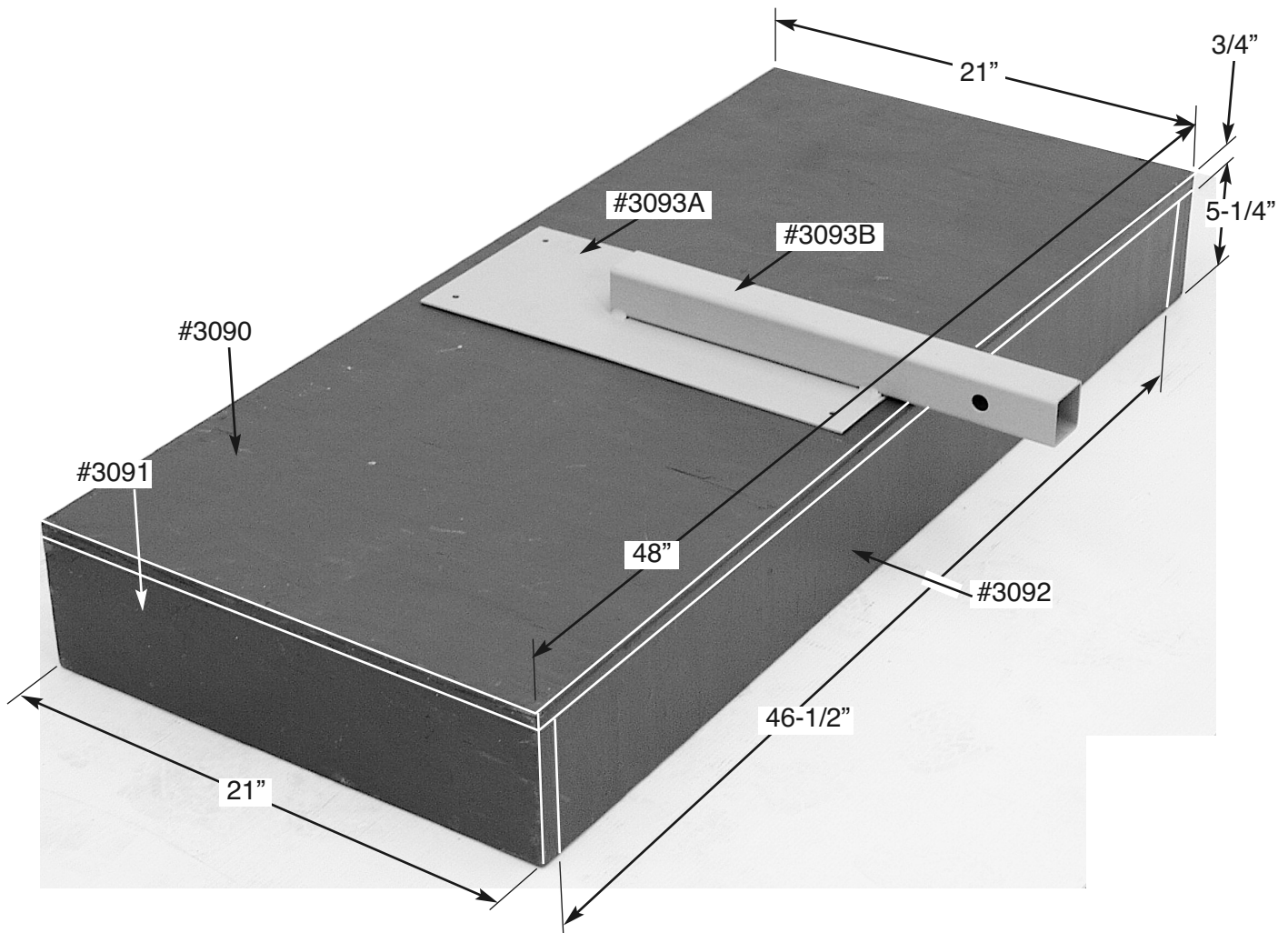

KIT #MB318 Rear Bumper

Parts List

3076	Rear Bumper (2)
3111	Screw, Pan Hd, #10x3/4 (4)
#8	Washer (4)

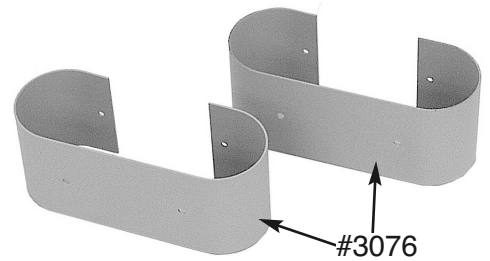

Assembly

STEP 1. Per “photo-drawing” below, locate your #3076 Bumpers on *lower rear* of #3009 Back Panel. Using the Bumpers as templates, mark center of each of the two holes in each Bumper.

STEP 2. Remove Bumper and 3/32” Drill 1/2” deep. Place Bumper back over holes and secure with #8 Washers and #3111 Screws. **NOTE:** a hole is provided in *outside face* of Bumper to allow a screwdriver to pass through and tighten Screws. [It’s suggested to “silicone seal” all screw holes!]

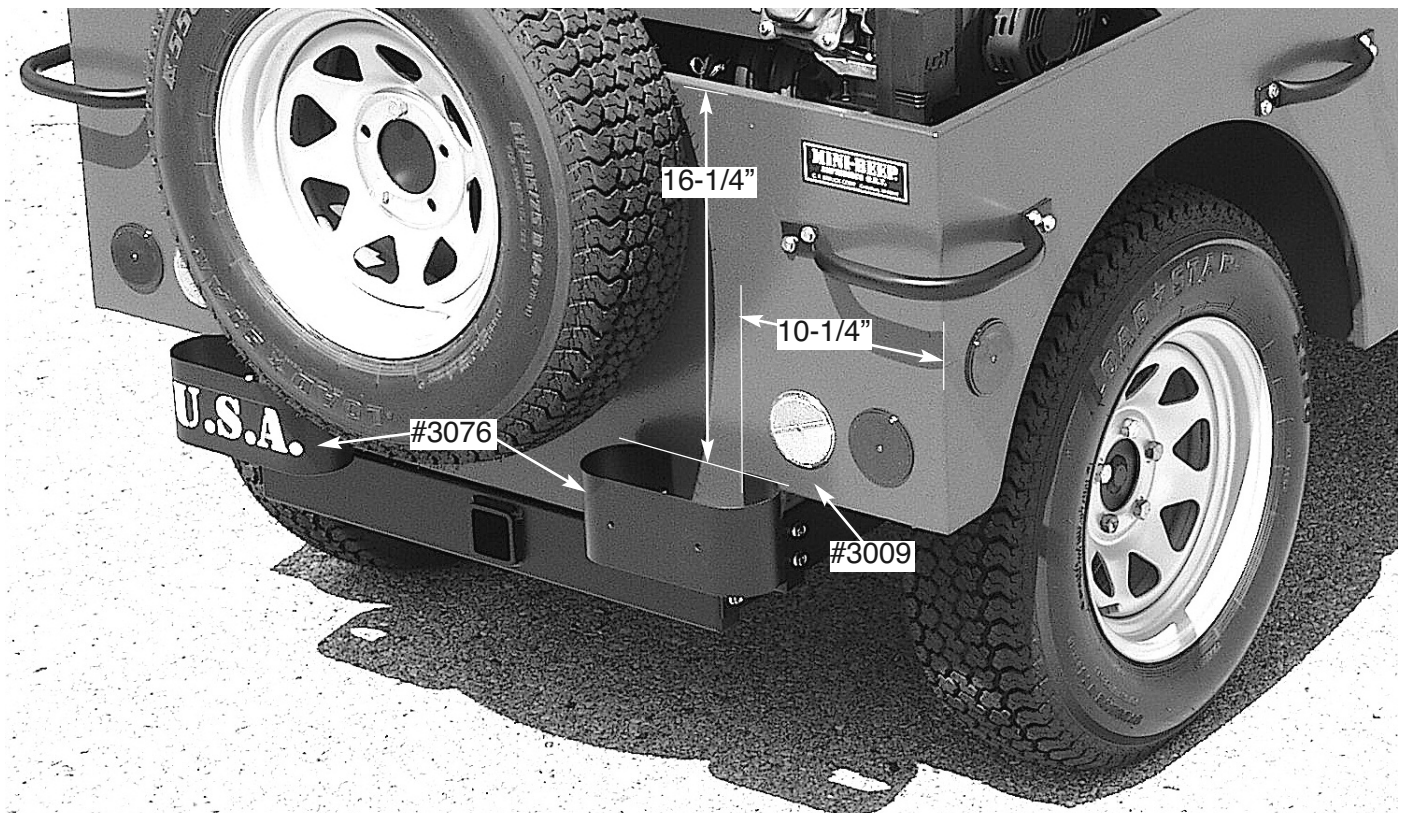

KIT #2317 Passenger Seat

Parts List

933A	Seat	5/16-18x1-1/2	Flat Head Screw (4)
933D	Washer, Seat	5/16	Washer (4)



STEP 1. Per Drawing next page, duplicate the eight (8) 11/32" *hole pattern* on left side of #3042 Seat Board to right side of Seat Board... see photo-drawing (below) and drawing (next page).



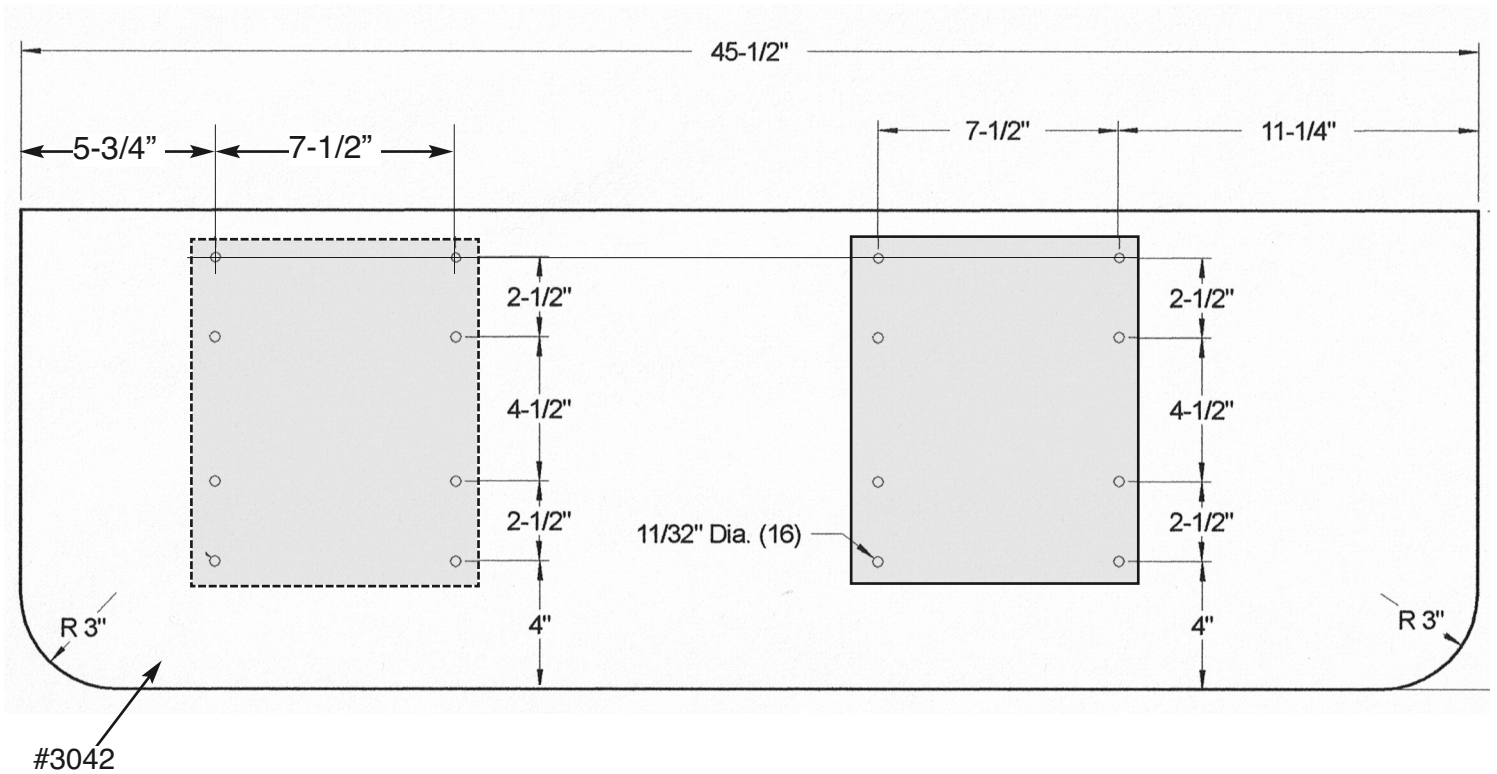

NOTE: On reverse side of #3042 Seat Board, “countersink” your eight (8) *new* 11/32” holes. This will allow the head of each 5/16 Flat Head Screw to be flush with the underside of Seat Board after tightening.

STEP 2. Following STEP#1 (page C66) in MINI-BEEP Body Plans/Kit Assembly Manual, mount your “Passenger Seat” using the parts furnished in this KIT... 5/16 Washers are not required due to your using Flat Head Screws.

KIT #MB322 Electric Start Upgrade

Parts List	1/4-20x1	Cap Screw (2)
	1/4-20	Nut, Spinloc (2)

NOTE: With the exception of the Rectifier Block, all components provided in this KIT come mounted to the Engine. Customer must provide Battery, Battery Case with mounting hardware and Cables to fit his installation.

SPECIAL NOTE: Due to the potential dangers involved, it is strongly recommended that only an individual with competent Engine *electrical* experience should attempt to hook up the Battery and Battery Cables that the builder is required to provide!

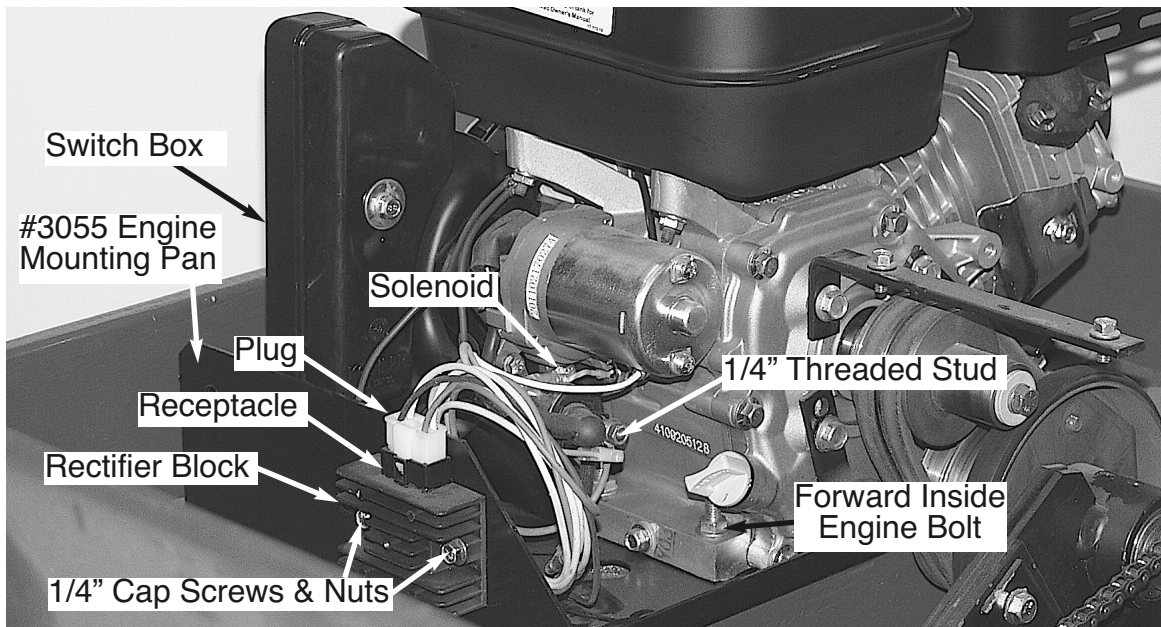

STEP 1. Using two 1/4-20x1 Cap Screws and 1/4-20 Nuts, mount the Rectifier Block to the *front face* of the #3055 Engine Mounting Pan with *plug receptacle* pointing up... tighten.

STEP 2. Insert "Plug" from wiring harness into top receptacle of Rectifier Block.

Two Cables must be prepared by the Builder:

Cable #1: *Red (+)* with 1/4" hole in the terminal on one end; other end a terminal to match (+) battery terminal *threaded stud*. Length determined by builder's battery location.

Cable #2: *Black (-)* with 5/16" hole in terminal on one end; other end a terminal to match (-) battery terminal *threaded stud*. Length determined by builder's battery location.

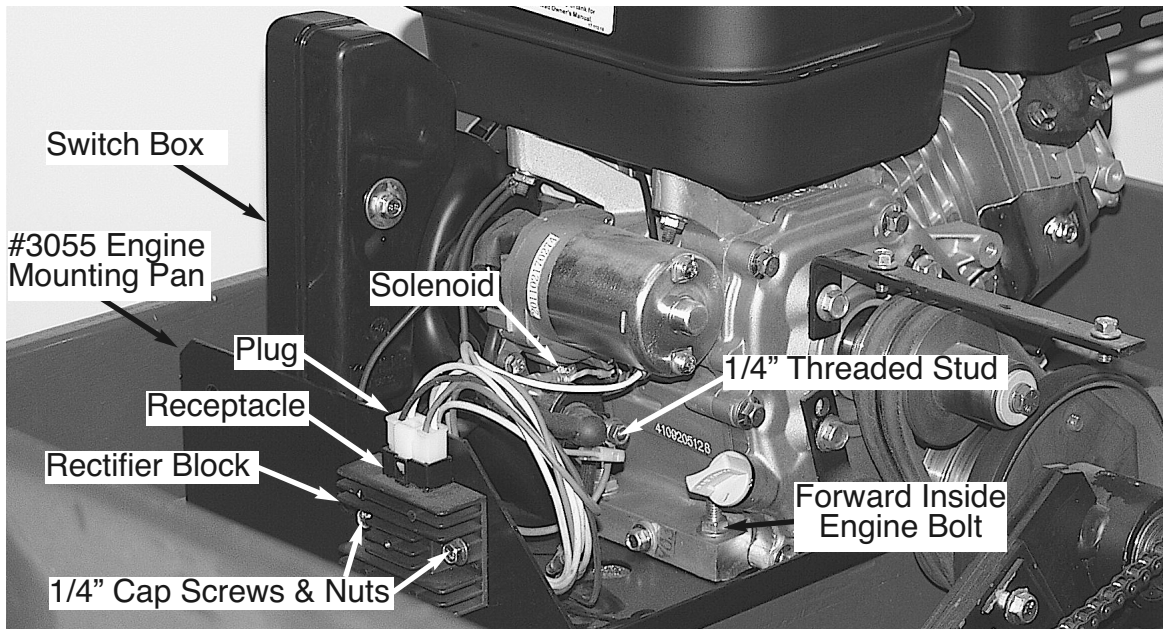

[DANGER: The remaining ends of the Battery Cables should not be attached to the Battery at this time!!]

Cable #1: *Red (+)* with 1/4" hole in the terminal routed to the 1/4" *Threaded Stud* on end of Solenoid and secure with nut. (Check location in Photo above).

Cable #2: *Black (-)* with 5/16" hole in terminal routed to forward inside *Engine Bolt*. (See location in Photo above)

The remaining ends of these two cables are routed to match Battery's appropriate (+) and (-) threaded terminal studs and are connected.

SPECIAL NOTE:

Holes are provided in the #3055 Engine Mounting Pan to accommodate a customer provided and installed remote Throttle Wire and Safety Tether Switch. (Photo at right)

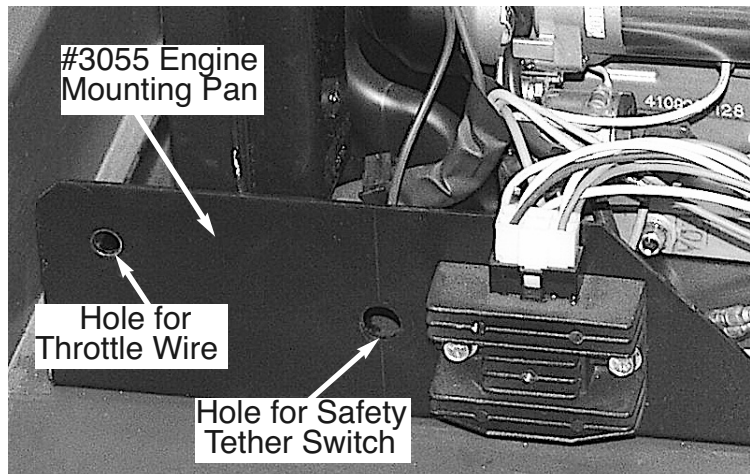

KIT #MB321 Front Mounting Hitch

Parts List

3198	Segment, upper (2)	3201	Strip	5/16x1-1/2	Cap Screw (5)
3199	Rear Tube As'mbly	3202	Front Tube As'mbly	3/8x1	Cap Screw (4)
3199A	Segment, lower	3199B	Tube	1/2x3-1/4	Cap Screw (2)
3199B	Tube	3202A	Tube	5/8x2	Cap Screw
3200	Angle Assembly	3202B	Tube	5/8x4-1/2	Cap Screw
3200A	Angle	3202C	End	5/16x3/4	Carriage Bolt (10)
3200B	Tube with 5/8x11 Nut	3202E	Gusset	5/16-18	Nut, Spinloc (15)
		3202F	Plate	3/8-16	Nut, Spinloc (4)
		3203	Coupler Plate (2)	1/2-13	Nut, Spinloc (2)
				5/8-11	Nut
				5/8-11	Locknut

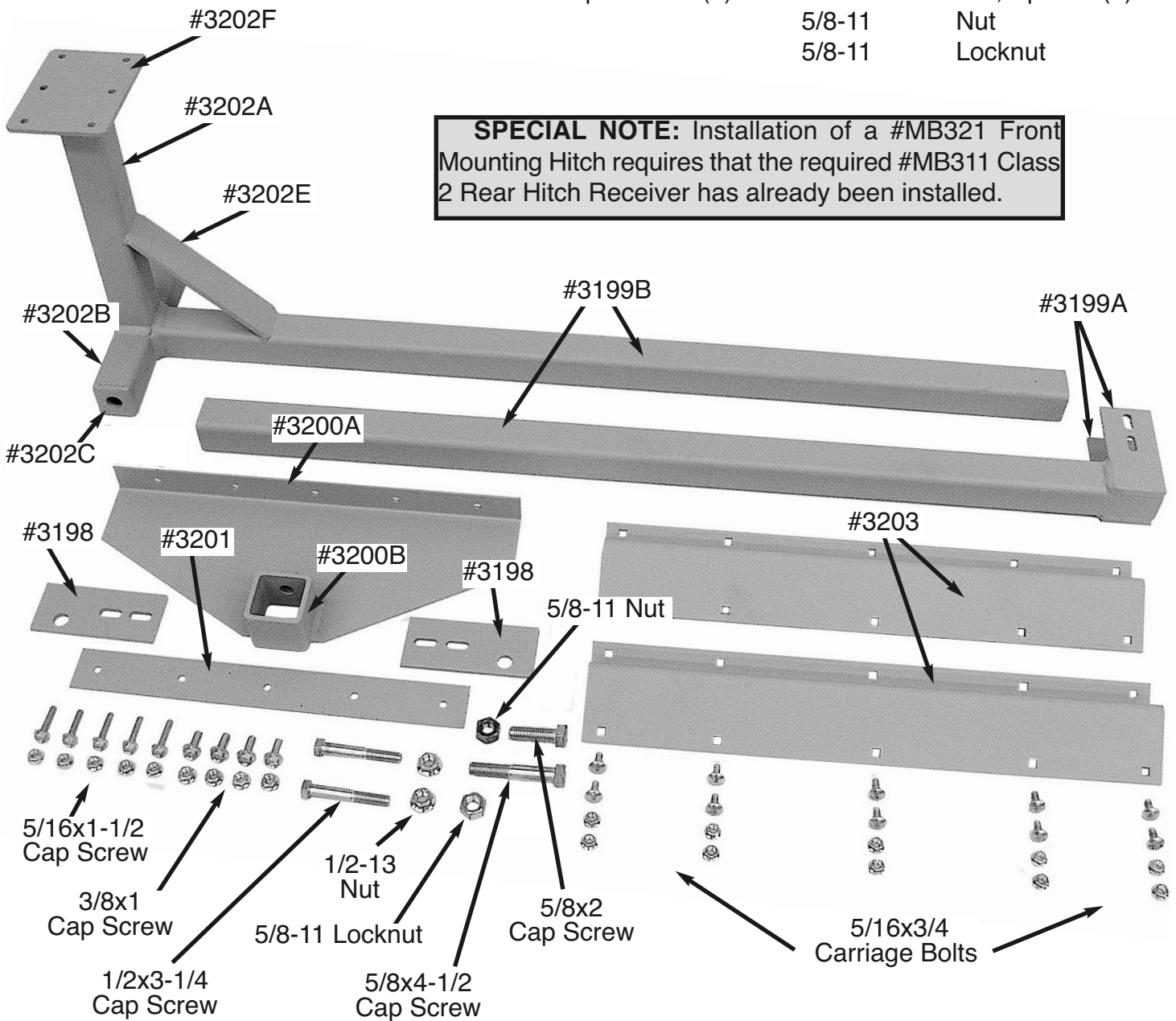

Assembly

STEP 1. Screw 5/8x2 Cap Screw *all the way* into mating 5/8-11 Nut [**DO NOT** use the 5/8-11 *Lock Nut* that has “dots” pressed into three of it’s sides] Screw this *assembly* into the Nut welded to the top of #3200B Tube and give it a couple of turns... see Photo below.

STEP 2. Slide the tube portion of this Assembly over the end of #3199B Tube of the Front Tube Assembly... leave Assembly loose... See Photo below.

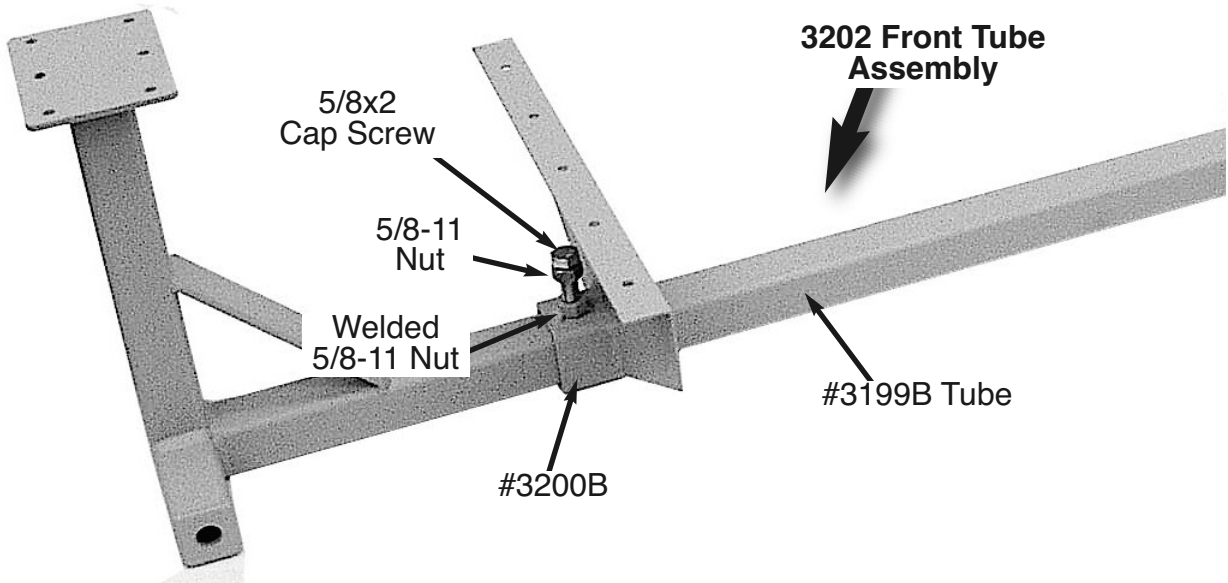

STEP 3. Using 5/16x3/4 Carriage Bolts and Nuts assemble the two #3203 Coupler Plates over their respective #3199B Tubes of their Front & Rear Tube Assemblies. Note the direction the Bolts are facing... you want the *top side* and the *bottom side* of the finished Coupler Assembly *smooth* after assembly... See Photo below.

STEP 4. Insert *horizontally* two 1/2x3-1/4 Cap Screws into remaining 1/2” holes of Coupler Assembly and secure with 1/2-13 Spinloc Nuts... leave loose! See Photo below.

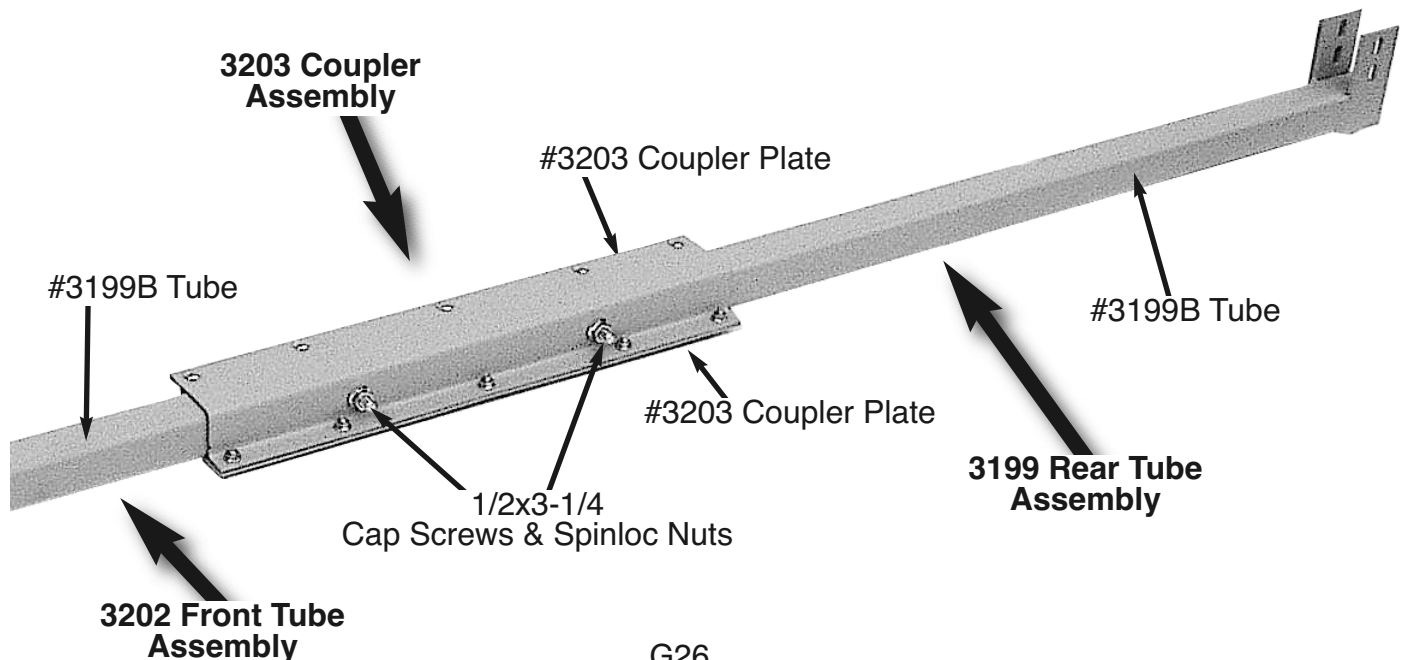

STEP 5. Slide both #3199B Tubes firmly into their respective ends of Coupler so each touches it's respective 1/2x3-1/4 Cap Screw... See Photo above.

STEP 6. Firmly tighten all ten (10) 5/16x3/4 Carriage Bolts and Nuts. Firmly tighten the two 1/2x3-14 Cap Screws... See Photo below.

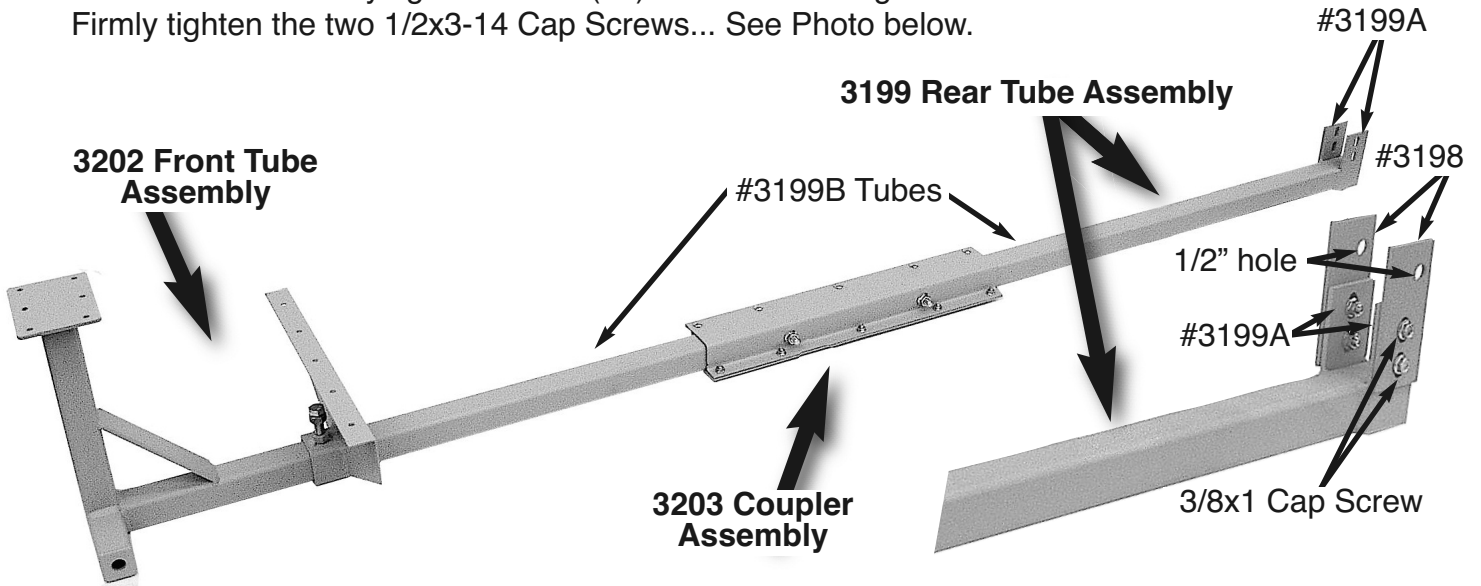

STEP 7. Using four (4) 3/8x1 Cap Screws and 3/8-16 Spinloc Nuts, mount each #3198 Segment to *outside face* of its respective #3199A Plate on end of Rear Tube Assembly... center 3/8" slots on each other... Tighten! NOTE: Remaining 5/8" hole in each #3198 Segment faces to the rear... See Photo above.

STEP 8. Using the centerline of the #3001 Floor and the locations of the (8) 5/16" Holes for the Front Axle as a reference; locate and mark the Five (5) 5/16" holes in #3201 Strip on the #3001 Floor. Using care to keep your drill *perpendicular* to the Floor, drill your five 5/16" holes... See Photo below. Remove #3201 Strip!

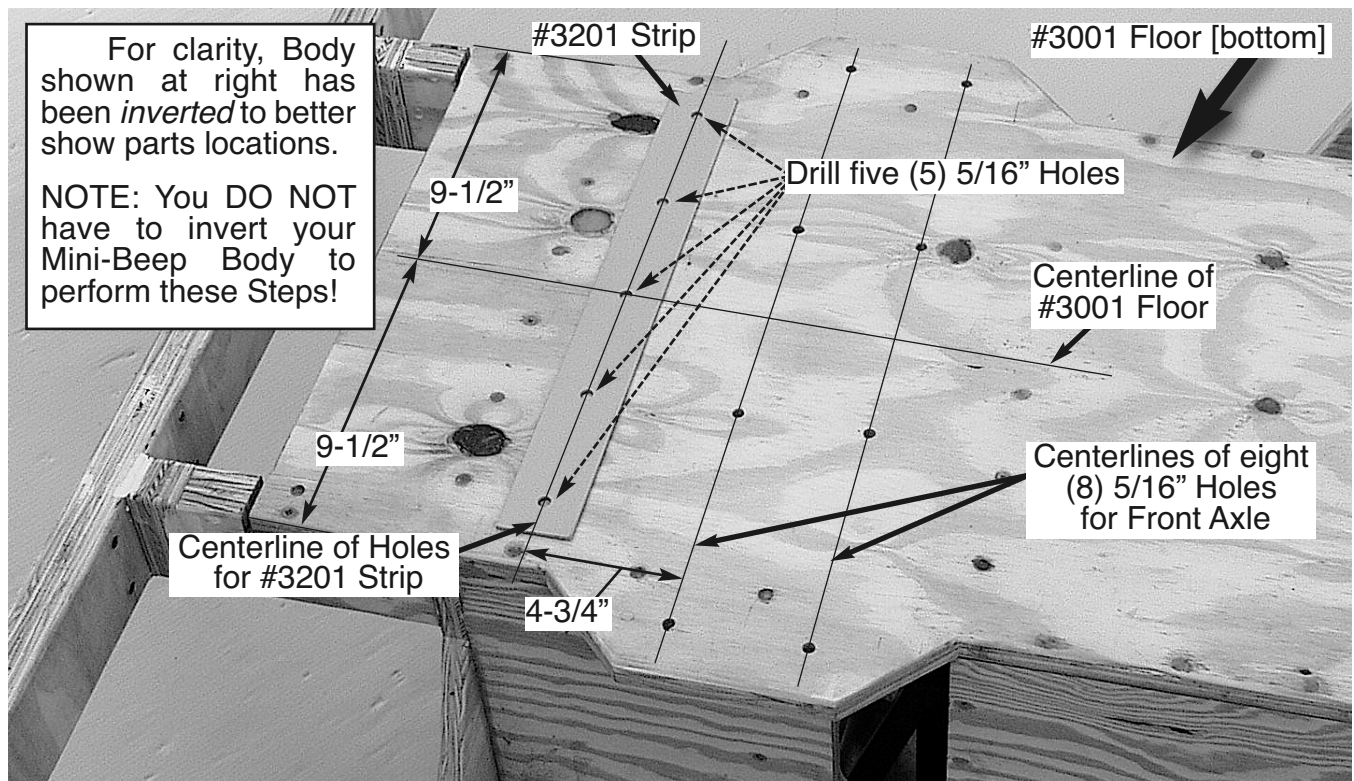

STEP 9. Slide your Front Mounting Hitch Assembly under your Mini-Beep Body. Support this Assembly in position such that the five (5) 5/16" holes in #3200A Angle are aligned with the 5/16" holes drilled in #3001 Floor in STEP 8 above.

STEP 10. From *below*, insert 5/16x1 Cap Screws into each 5/16" hole in #3200A Angle and push fully into mating 5/16" holes in *bottom* of #3001 Floor. Slip #3201 Strip over protruding Cap Screws on *top* of Floor [inside Body]... secure with 5/16-18 Nuts... leave loose!

Photo View:
Looking up at the *underside* of Mini-Beep Body with **MB321 Front Mounting Hitch Assembly** in place.

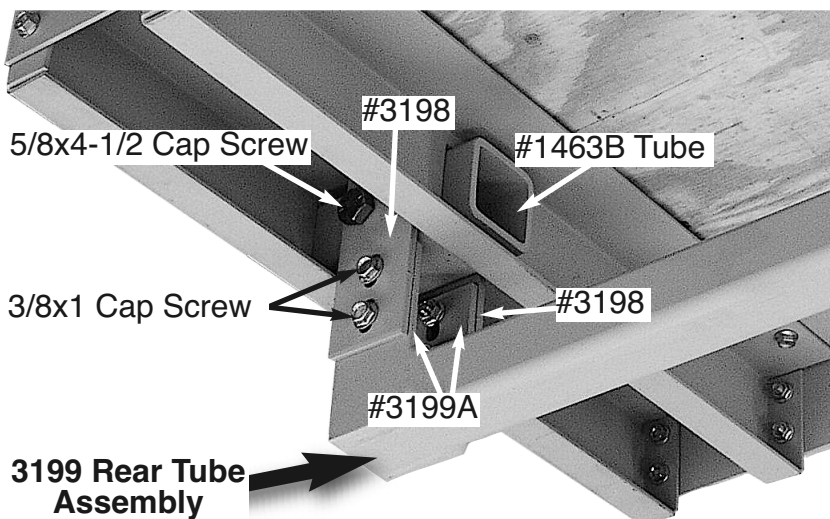
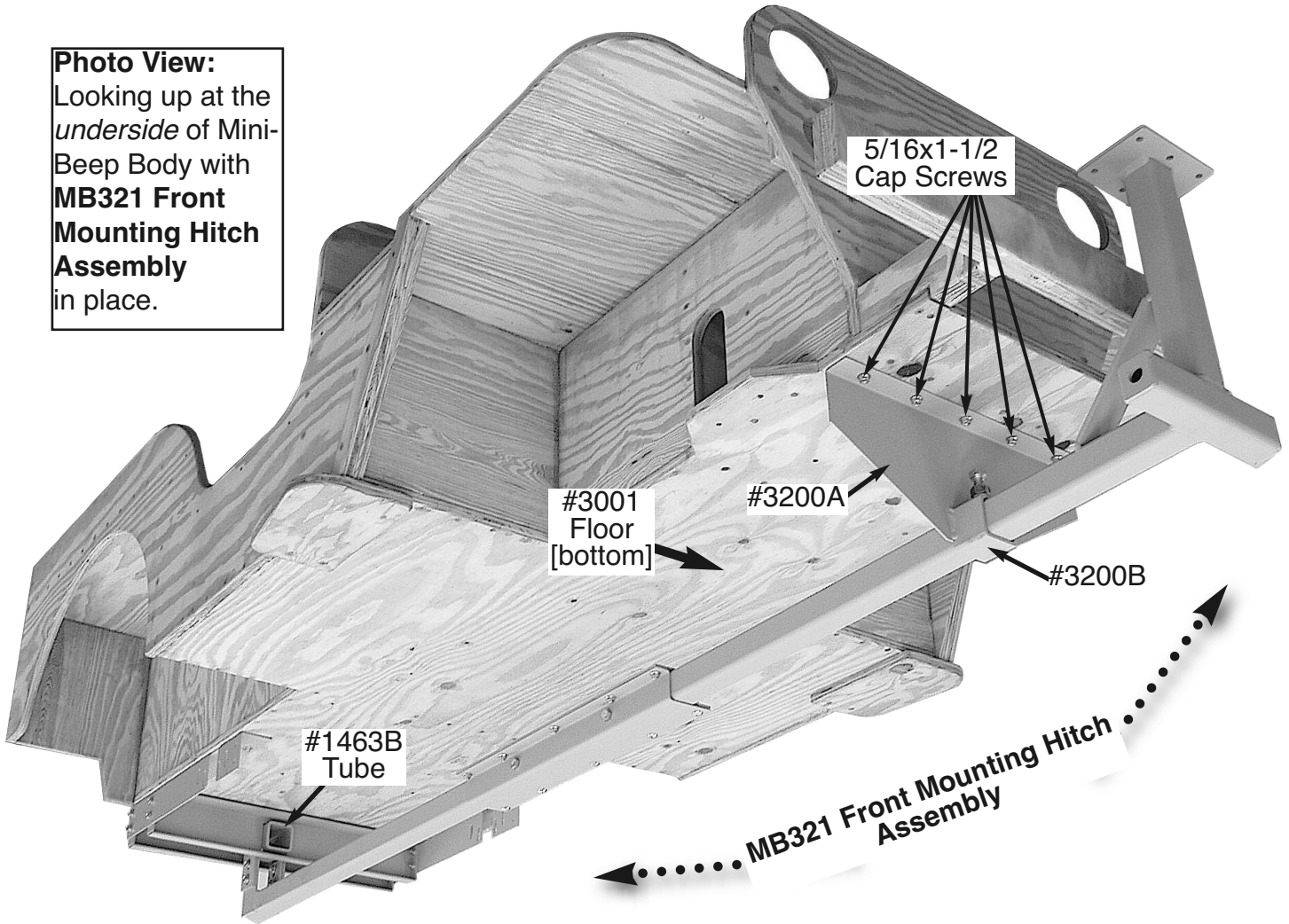

STEP 11. Slide *inside face* of each #3198 Segment around mating *outside face* of #1463B Tube... align 5/8" holes in Segments & Tube! Insert 5/8x4-1/2 Cap Screw through aligned holes... secure with 5/8-11 Lock-nut... leave loose!

NOTE: You may have to slide the Front Mounting Hitch Assembly forward and back to align all holes and to relieve pinching of Front Tube Assembly in #3200B Tube.

STEP 10. “Square & align” your complete Front Hitch Assembly; then tighten all Cap Screws used in the assembly. When satisfied, tighten the 5/8x2 Cap Screw in #3200B Tube and secure with Locknut *above*.

Congratulations...

You have completed your
KIT #MB321 Front Mounting Hitch
Assembly and Installation!

To The Builder... With the completed assembly of your new MB321 Hitch, you now have a solid base to attach a Blade, Bucket, or Front Lift to your new Mini-Beep.

Check with our Factory... for Attachments from 3rd party suppliers that will fit your new MB321 Front Hitch. [Note the dimensions detailed below to help you make sure which attachments will fit your new Front Hitch]

KIT #MB321 Front Mounting Hitch Assembly

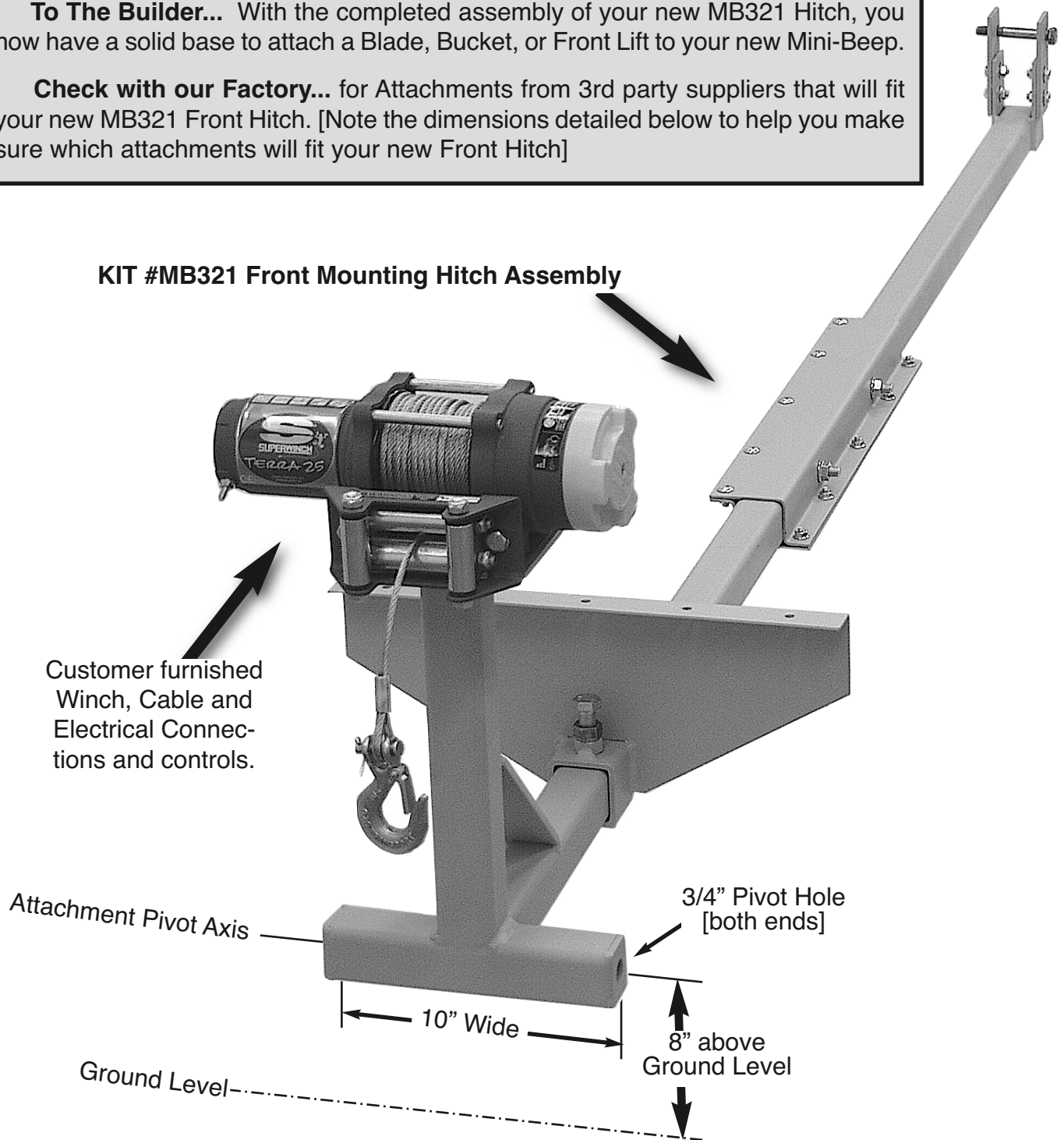

No portion of this Plans/Assembly Manual, drawings, step by step instructions, DVD's, or photos may be reproduced or utilized in any form or by any means, electronic or mechanical, including photocopying, recording or by any information storage and retrieval system, without prior written permission of the original copyright owner.