

MAGNATRAC®

Compact Crawler Tractors

BUYER'S GUIDE

MH Series



MH8500 - The Contractor

MAGNATRAC® MH8500 - Assembled.

Includes KUBOTA D1305-E4B DIESEL Engine. 3 cylinder, quiet and clean, vertical 4-cycle liquid cooled, industrial diesel engine, LOFA industrial electric ignition with hour meter, battery and engine oil indicator lights, and 30 amp. alternator. Efficient, tandem piston pump hydro-static drive system with contractor-grade drive handles, standard 5 bank attachment control valve with two float spools and contractor-grade seat with rotatable arm rests. (Fully adjustable forward/reverse, up/down). Hour meter, hydraulic oil temp gauge, RPM gauge, and dual LED headlights included. Easy Oil Level System with oil-sight window, NEW PFC™ Priority Flow Control System and TCP™ Tandem Chain Path track technology with 5 heavy-duty track rollers per side, easy access center axles and heavy-duty CA551X track chain.

Track Shoes not included - see Track Shoe Kits for the most traction (page 7). MH8500 shown with optional TSO40 Grouser Track Shoes.

MH8500 - Magnatrac Hydro (With no attachments). 2,100 lbs.

Specifications & Ratings

SPECS **MH8500**

<p>Engine Make & Type Kubota D1305-E4B, 3 cylinder [DIESEL] approx. 25 HP</p> <p>Torque / Starting / Amps 59 lb ft / Industrial LOFA ignition / Glow Plug & 30 amp. alt.</p> <p>Air Cleaner Inner and Outer air filter elements</p> <p>Track Drive Pump 1.33 in³ per rev., Dedicated 19.6 GPM @ 3,000 PSI</p> <p>Attachment Pump 0.66 in³ per rev., Dedicated 15 GPM @ 3,000 PSI</p> <p>Fuel Tank Remote, 5+ gal. capacity, includes fuel gauge</p> <p>Hydraulic Oil Cooler Internally mounted, engine fan cooled 9" Fan.</p> <p>Attachment Valve Five (5) bank valve (Includes 2 float sections)</p> <p>Track Motors 125cc or 7.67 in³ per revolution</p> <p>Travel Speeds Variable Regular Drive.....0 - 3 MPH</p> <p>Instrumentation Hour meter, hydraulic oil temp. & RPM gauge</p> <p>Headlights LED Headlights (2)</p> <p>Track System Type TCP - Tandem Chain Path (Dual chains each track) 48" long x 9-1/2" wide / 5.36 sq. ft.</p> <p>Number of Track Pads 72 total, 36 per side</p> <p>Tensioning Type Industrial grade coiled steel springs (4)</p> <p>Pad Thickness 1/4" thick steel</p> <p>Pad Size 3" wide x 9-1/2" long</p> <p>Chain Sprockets Induction hardened steel</p> <p>Track Sprockets 3/8" thick AR200 pre-hardened steel, plasma cut</p> <p>Track Guide Rollers 4-1/2" diameter, 5/8" thick flanges, Solid steel (5) per side with Quick Release Center Axles</p> <p>Track Chain Double lengths #CA551X Chain, 40,000 ultimate strength per Track</p> <p>Track Shoe Options 9-1/2" wide, 7/16" diameter overall laminated thickness, Grousers and Rubber Pads available (See TSO40 Grouser Shoes and RP72 Rubber Pads)</p> <p>Primary Drive Chain 60R, 9,200 lbs. tensile strength</p> <p>Final Drive Chain 80HK, 22,046 lbs. tensile strength</p> <p>Axle Diameters 7/8" dia. on Idlers; 1-3/16" diameter on Track Sprockets</p> <p>Parking Brake Dual 8" diameter disk type</p> <p>Battery Type / Group # 12V / #75-1</p> <p>Battery CCA 750 CCA</p> <p>Base Weight 2,100 lbs. with no attachments</p> <p>Track Tensioning Industrial grade coiled steel springs (4)</p> <p>Track Ground Contact 5.36 sq. ft.</p> <p>Seat Type Contractor-Grade with arm rests, Forward/Reverse Glides, Rotatable, height settings with Pin.</p> <p>PFC Attachment Control Standard, PFC™ Priority Flow Control System</p> <p>PTO Power Take-Off Optional, hydraulically driven, 1 3/8" dia., 6 splined, 540 RPM, approx. 20 hp. output at PTO</p>	
--	--

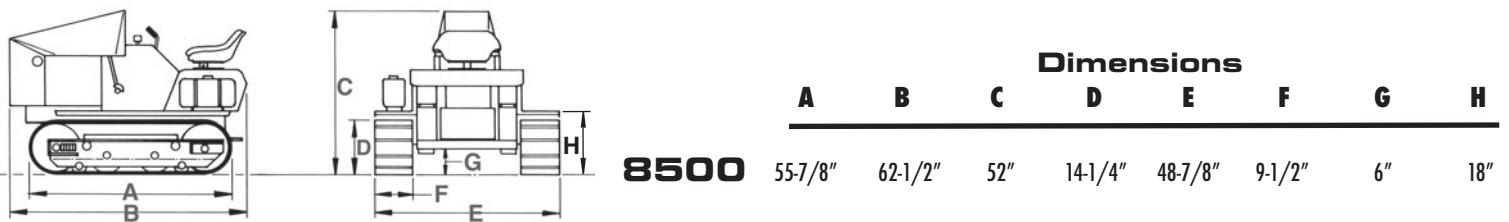

The Struck Corporation has a policy of continuous product improvement and reserves the right to change its products, specifications and dimensions at any time without notice or obligation. All dimensions and specifications are based upon best possible performance using the highest performance components available and running at 100% efficiency. Results will vary due to changes in size of engine and components, component wear, oil temperature, etc. If a particular specification or dimension is critical to your application contact the factory for more detailed information. Prices do not include transportation charges or any state or local taxes if applicable.

Front Mounted Attachments

SWB54 Six-Way Blade - Assembled.

Extra heavy-duty, fully reinforced 54" wide x 22" high x 1/4" thick solid steel 6 way blade with 3/4" thick x 4" wide heat-treated "plow steel" cutting edge. Great for making berms and creating trails. Mounts directly to lower track frame for superior support. Complete with lift, tilt, and angle cylinders, hoses, fittings, mounting hardware. Features an extra heavy-duty front lifting system with total control of: lift, float, down-pressure, 25° left & 25° right angling and 9° of tilt above and 9° below horizon. **Must completely remove the HL900 Loader to use.** Works best when used together with the RH65 Three Point Hitch or FB150 Ballast Box filled with proper counterweight.

SWB54 Six-way Blade Kit 525 lbs.

SIX-WAY BLADE SPECIFICATIONS

BLADE WIDTH	54"
TILT ANGLE (above/below horizon)	9°
BLADE ANGLE (left/right)	25°
LIFT (above/below grade)	8.5" / 4"
LIFT FORCE (at cutting edge)	255 lbs.

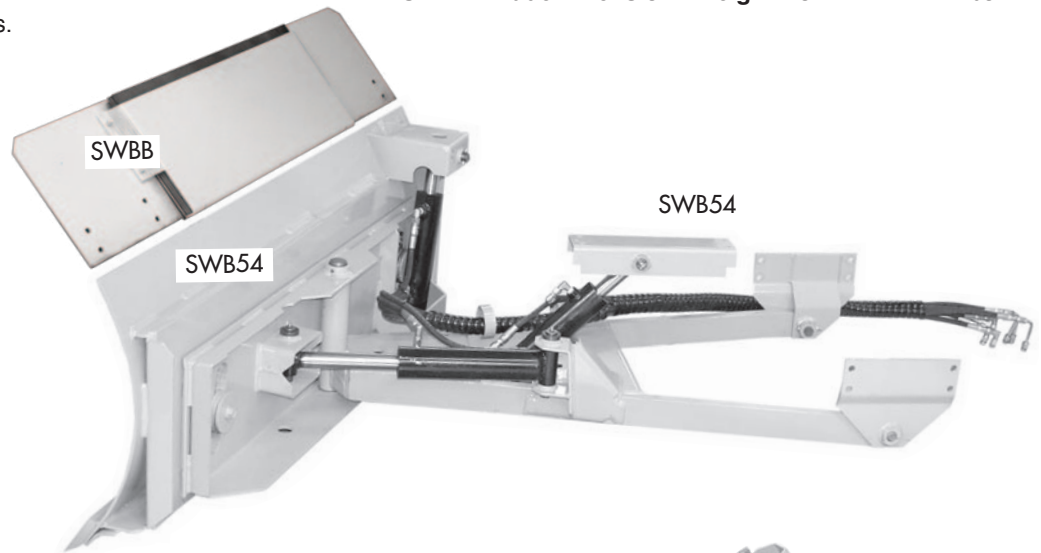
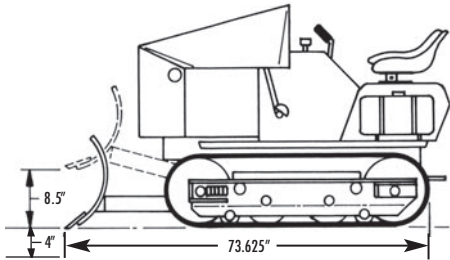

SWBB Blade Extension & Weight Box - Assembled.

9" Blade extension protects brush from the front grill, and increases blade's down pressure by 221 lbs. Perfect for pushing brush, wood chips, grain, snow, etc. A must if using the SWB54 Six Way Blade with a backhoe. **For the best SWB54 Six Way Blade grading results: we recommend using the SWB54 Six Way Blade with the RH65 Three Point Hitch or FB150 Ballast Box filled with appropriate weight.** Removal of Backhoe is advised.

SWBB Blade Extension / Weight Box Kit . . . 221 lbs.

HL900 Loader - Assembled.

93" Lift, 2,300 lb. bucket breakout, 800 lb. maximum lifting capacity at full height. All-hydraulic bucket curl/dump, lift, float and down pressure functions. Lift cylinder safety lock included to hold loader arms up for maintenance. This is our most popular front attachment! This loader is built with "dozer power" strength for digging, and has the height to topple small trees. **Bucket not included;** choose from selection (see page 4). Loader fully assembled on unit, unless SWB54 is purchased as well. If you purchase both: Your choice of which attachment gets mounted to the unit: SWB54 6-Way Blade or HL900 Loader.

HL900 Loader Kit. 570 lbs.

LOADER SPECIFICATIONS

LIFT ABILITY (at 93" high)	800 lbs
BREAKOUT (at lift arms)	2000 lbs
BREAKOUT (at bucket)	2300 lbs
DUMP ANGLE	32°
DUMP HEIGHT	79"
LIFT HEIGHT	93"
ROPS HEIGHT (with track shoe)	80 3/4"

Bucket Capacity (heaped)

EB460 (4 pin mount)	5.9 cu. ft.
SB480S, SB480TS (universal mount)	8.0 cu. ft.

CYLINDER SIZES

Lift -	2.0" Bore	1.25" Rod	24" Stroke
Bucket -	2.0" Bore	1.25" Rod	24" Stroke

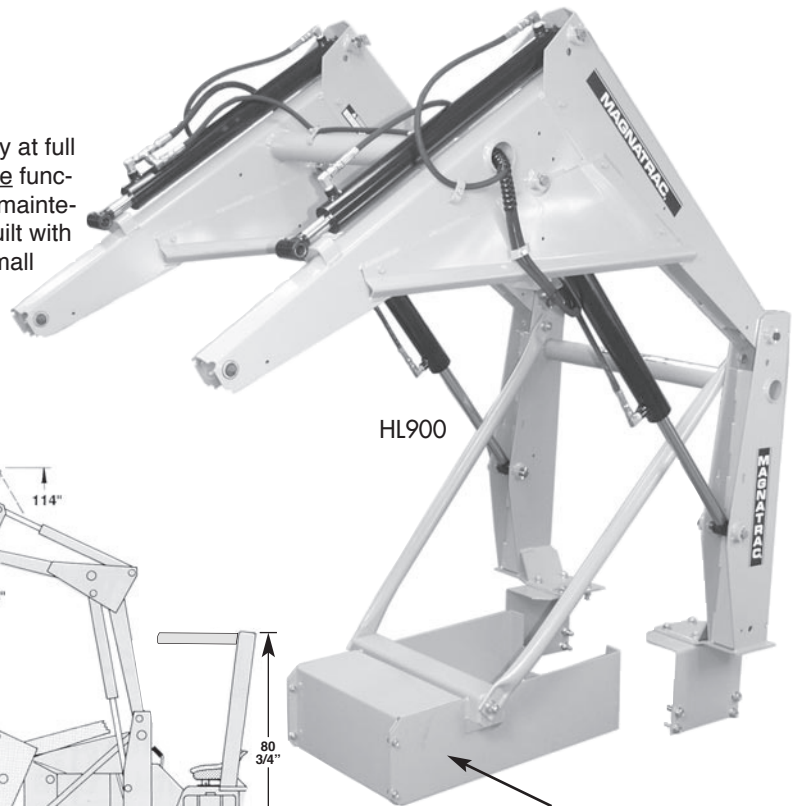
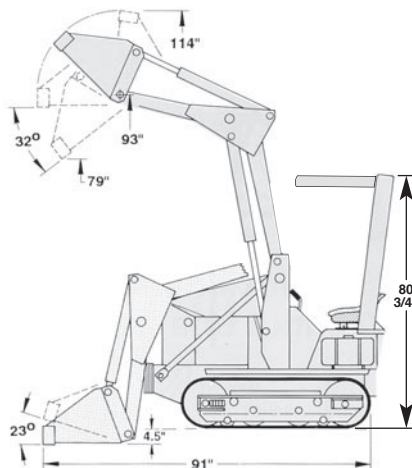

Note: Shown with weight box that comes with D108 Backhoe. Ballast weight not included. (See FW20 Ballast Kit). Standard loader support brace included with loader if D108 backhoe not purchased. (Not shown). Design of weight box may vary from what is shown.

HL900 Loader Attachments

4 Pin Mount



EB460

EB460 Excavating Bucket Kit

48" wide x 15" high x 19" deep excavating bucket. Attaches with four Pins. Has bolt-on replaceable cutting edge. For tougher work add T10 Tooth Bar (see below).

EB460 Excavating Bucket Kit . . . 135 lbs.



T10

T10 Tooth Bar Kit

Bolt-on replaceable bar with 10 hardened "plow steel" teeth. Gives EB460 Excavating Bucket (see above) greater digging ability.

T10 Tooth Bar Kit15 lbs.



MDB154

MDB154 Angling Blade Kit

Mounts to Loader in place of Bucket with 4 pins. Loader's hydraulics control blade's lift. Adjust 3 position blade's angle with single pin - no tools!. [Add CK29 Cylinder Kit (below) for hydraulic angling]. Blade is 54" wide, 17" high and 3/16" thick.

MDB154 Angle Blade Kit 230 lbs.

CK29 Cylinder Kit

2" bore x 7 1/2" stroke cylinder allows you to angle your Blade with finger-tip hydraulic control. Comes complete with quick connect fittings and all hoses.



CK29

CK29 Cylinder Kit 20 lbs.

Universal Mount

SH44 Speed Hitch Kit - Assembled.

Universal skid steer mounting Hitch allows HL900 Loader to quickly change out attachments, and utilize 3rd party attachments including augers, tillers, trenchers, snow blowers, grapples, pallet forks, and many more! (See top of page 8) Check with attachment manufacturer for requirements.

SH44 Speed Hitch Kit 105 lbs.

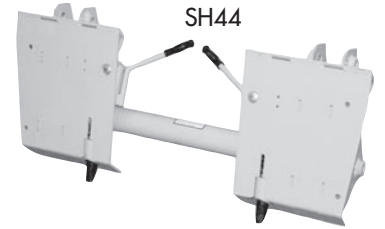

SH44



SB480S

SB480S Material Bucket Kit

Heavy-Duty 48" wide x 19" high x 21" deep excavating bucket for use with SH44 Speed Hitch on HL900 Loader. Has beveled, heat-treated, "plow steel" cutting edge welded to bucket forward edge.

SB480S Bucket 170 lbs.



SB480TS

SB480TS Excavating Bucket Kit

Heavy-Duty 48" wide x 19" high x 21" deep-excavating bucket with six professional-quality replaceable teeth made of special "abrasive resistant" cast steel. Tooth adapter welded to bucket edge.

SB480TS Bucket 200 lbs.

MDB154S Angling Blade Kit

Uses Loader's hydraulics to control blade's lift. Adjust 3 position blade angle with single pin - no tools required. [Add CK29 Cylinder Kit (below) for hydraulic angling] Blade is 54" wide, 17" high and 3/16" thick.

MDB154S Angle Blade Kit 250 lbs.

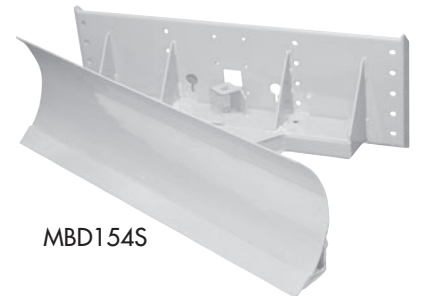

MDB154S

CK29 Cylinder Kit

2" bore x 7 1/2" stroke cylinder (see right) allows you to angle your Blade with hydraulic control. Comes with quick connect fittings and all hoses.

CK29 Cylinder Kit 20 lbs.



CK29

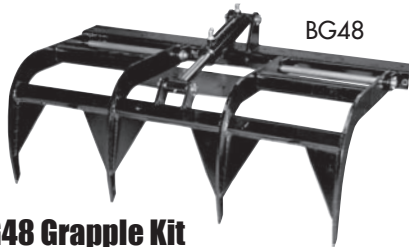

BG48

BG48 Grapple Kit

Mounts to (SB480S, & SB480TS) Buckets. Consists of four solid steel tines robotically welded to heavy-duty frame, developing over 1,000 lbs of clamping force. Opens completely to allow normal bucket operations. Great for grabbing logs & brush!

BG48 Grapple Kit 145 lbs.



HK12

HK12 Auxiliary Hose Kit - Assembled.

Loader arm mounted, front auxiliary 1/2" hose kit with flat faced couplers. Allows easy hydraulic connection of dozens of third party compatible SH44 Speed Hitch attachments. (See top of page 5 & 8)

HK12 Auxiliary Hose Kit 5 lbs.

EA14 Earth Auger Drive Kit

Great for planting trees or putting in fence posts! These planetary drive units produce high torque at low speeds, allowing for lower maintenance costs. Auger mounts to your optional SH44 Speed Hitch (Universal skid steer front mounting hitch), and has factory installed quick connect fittings. Does not include auger bits. **Requires HL900 Loader, SH44 Speed Hitch & HK12 Auxiliary Hose Kit.** (Design may vary from picture).

EA14 Earth Auger Kit - planetary drive, 2" Hex Head, self centering design 160 lbs.



Auger Bits

EAB9 9" Auger Bit - 9" wide, 2" Hex, single flight 37 lbs.
EAB12 12" Auger Bit - 12" wide, 2" Hex, single flight 50 lbs.
EAB24 24" Auger Bit - 24" wide, 2" Hex, single flight 75 lbs.

Rear Mounted Attachments

RH65 Three Point Rear Hitch - Assembled.

Full size, all-hydraulic, **Category #1** three point Rear Hitch providing "lift, float, and down pressure" to both lift arms. **Does not include PTO70 Power Takeoff.** When combined with PTO70 (See below), allows usage of dozens of 3rd party farm implements such as: tillers, brush mowers, log skidders, rippers, and many more! (See top of page 8). Includes cylinder safety lock to hold hitch "up" when disconnecting hydraulic source. Develops 1,000 lbs. Lift. (Requires HL900 Loader or SWB54 for proper balance) Rear hitch fully assembled, but on secondary pallet.

RH65 Rear Hitch Kit 240 lbs.

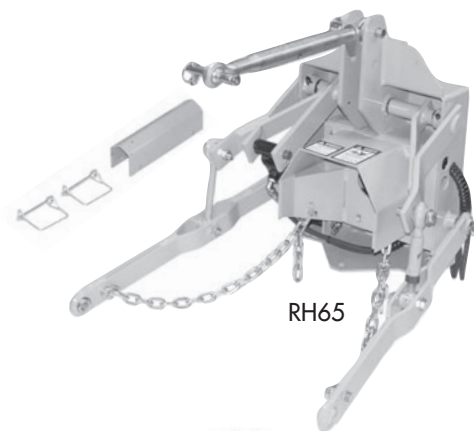

RH65



PTO70

PTO70 Power Takeoff - Assembled.

Full power hydraulic motor with standard 1-3/8" diameter, six splined shaft. Mounts in "cavity" of RH65 Three Point Rear Hitch. Complete with hoses, fittings and all mounting hardware. See model specification area for PTO hp output. (See page 2). PTO fully assembled, mounted to RH65.

PTO70 Power Takeoff Kit 24 lbs.

S14 Scarifier / Ripper Kit

Heavy-duty five tooth Scarifier / Ripper. Five scarifier teeth are interchangeable on heavy-duty mounting frame to create a variety of ripping patterns. Useful for shattering hard, dry soil, compacted driveways, etc.

S14 Scarifier / Ripper Kit 115 lbs.



S14

FB150 Ballast Box Kit

Required rear weight box for counter balance when using HL900 Loader without a backhoe or without a RH65 with any 750 lb. rear tractor attachment. **Comes with both rigid tractor mounts (shown at right) and with special RH65 Three Point Hitch mount as well.** FB150 Ballast Box not required if HL900 Loader and D108 Backhoe are mounted simultaneously.

Does **not** include steel ballast - order RW150 or purchase counter weight locally.

FB150 Ballast Box Kit 102 lbs.

RW150 Ballast Kit 750 lbs.

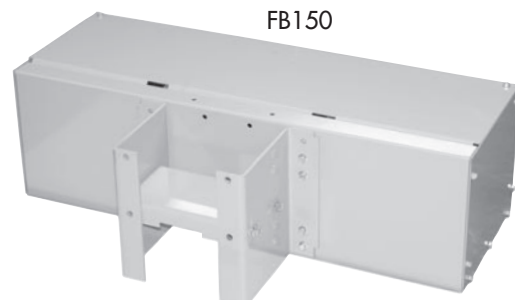

FB150

Rear Mounted Attachments

D108 Backhoe, 8ft - Assembled.

Backhoe with 8 ft. digging depth, 164° swing arc. Complete with cylinders, hoses, fittings, and six section hydraulic valve. Mounts to the rear of the unit and connects w/ 2 hoses and a few bolts. **Does not include "WC10 Wobble Controls", bucket or accessories.** Backhoe fully assembled, but on secondary pallet, unless a factory pick-up. HL900 Loader (loaded with FW20 Ballast Kit) or equivalent counterweight must be mounted to front of Magnatrac for proper balance.

D108 Backhoe Kit 865 lbs.
FW20 Ballast Kit 625 lbs.

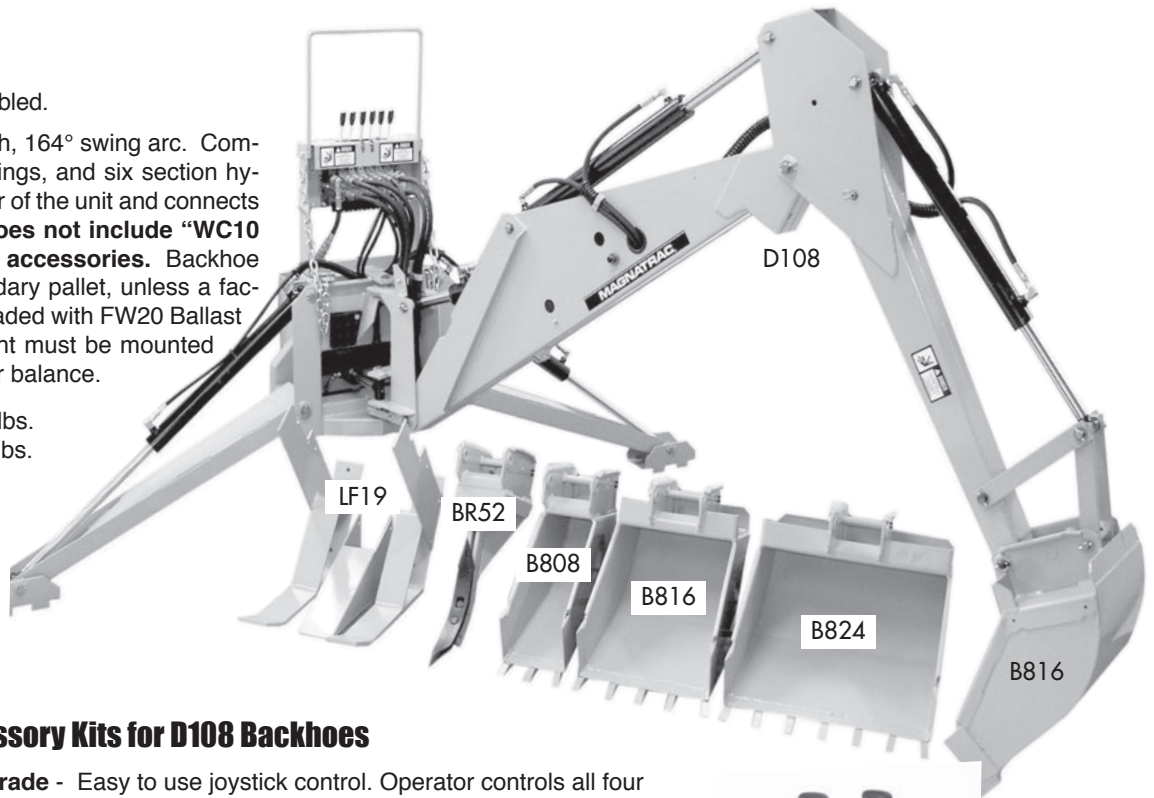

Backhoe Buckets & Accessory Kits for D108 Backhoes

- WC10 Wobble Control Upgrade** - Easy to use joystick control. Operator controls all four digging operations with only two control handles. . **(Factory option only)**
- B808 8" Bucket Kit** - Eight inch digging width 55 lbs.
- B816 16" Bucket Kit** - Sixteen inch digging width75 lbs.
- B824 24" Bucket Kit** - Twenty-four inch digging width95 lbs.
- LF19 Log Fork Kit** - Two "forks" bolt to interior of B816 or B824 Buckets (above) and an adjustable "thumb". [Requires drilling ten 1/2" holes in Bucket.]85 lbs.
- BR52 Frost / Chisel Tooth Ripper Kit** - Heavy-duty single tooth ripper with two replaceable teeth: (1) 16" x 2" 1/2" deep "plow steel" tooth for stone & frost picking & hardpan penetration to 18"; the other 17" x 1/2" x 2" deep tooth, allows root cutting to depths of 18". Mounts in place of Bucket 35 lbs.

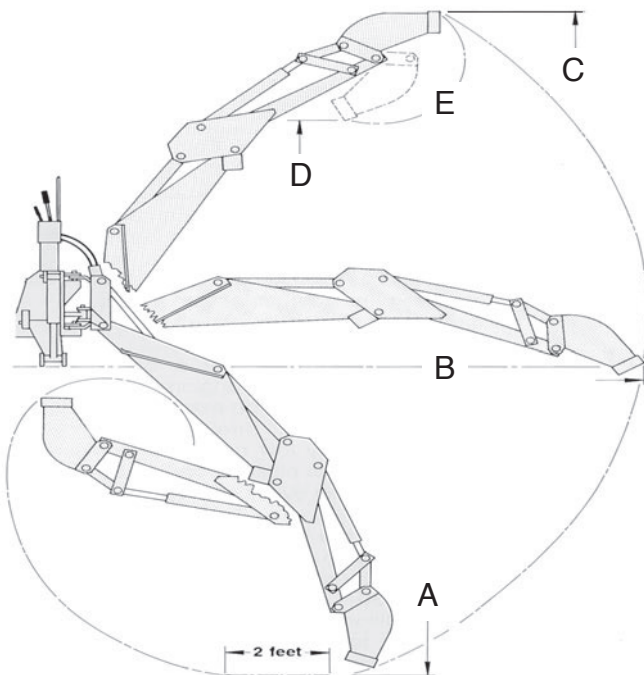

BACKHOE DIMENSIONS

A	B	C	D	E
99"	140"	118"	85"	200"

BACKHOE SPECIFICATIONS

BUCKET FORCE (at 2000 PSI)	3200 lbs.
DIPPER FORCE (at 2000 PSI)	3000 lbs.
LIFT ABILITY (Boom & Dipper Extended, at 2000 PSI)	
At bucket pivot point	500 lbs.
At dipper pivot point	800 lbs.
SWING ARC	164°
STABILIZER SPREAD (operating position)	119"
STABILIZER SPREAD (transport position)	48-1/2"
ASSEMBLED LENGTH (Loader & Backhoe)	180"
BUCKET CAPACITIES (heaped)	
B808	0.97 cu. ft.
B816	1.94 cu. ft.
B824	2.91 cu. ft.
CYLINDER SIZES	
Lift -	2.5" Bore 1.50" Rod 24" Stroke
Crowd -	2.5" Bore 1.75" Rod 24" Stroke
Bucket -	2.0" Bore 1.25" Rod 24" Stroke
Swing -	2.0" Bore 1.25" Rod 7.5" Stroke
Stabilizer -	2.0" Bore 1.25" Rod 24" Stroke

Upgrades & More

MS32 Mud Scrapers - Assembled.



Replaces standard center idler covers with heavy-duty covers, incorporating 1" thick solid steel bars to prevent mud and ice build-up between dual track sprockets as they rotate.

MS32 Mud Scrapers Kit 85 lbs.

SU930 Seat System Upgrade - Assembled.

Standard seat on the MH8500, this MH4900 upgrade includes: contractor grade seat system with foldable arm rests, fully adjustable Up/Down rotatable seat post mount & Forward/Back glide motion. *(MH4900 only)*

SU930 Seat Upgrade . . . 10 lbs.



ROPS85 Roll-Over Protective Structure - Assembled.

Safety-First! Even a MAGNATRAC'S low center of gravity and ground-gripping traction are no substitute for Roll-Over Protection (ROPS) on slopes and uneven ground. Includes: seat belt, installation hardware and special seat pan and mount to attach the ROPS to the rear of the MAGNATRAC.

ROPS85 Roll-Over Protective Structure Kit 465 lbs.

*** According to Federal Laws, no tractor can be operated by employees without a Roll-Over Protective Structure!*

For operator safety, a **ROLL-OVER PROTECTIVE STRUCTURE** is strongly recommended for all MH Series MAGNATRACS!

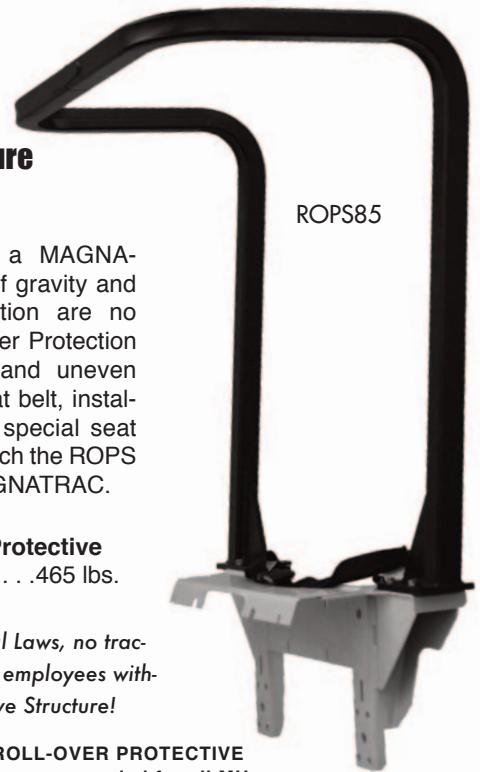

PFC19 Priority Flow Control Upgrade - Assembled.

Standard on the MH8500, this MH4900 upgrade gives professional speed control of your Backhoe or PTO using an easy to use dial & indicator light. Comes complete with hoses, fittings, valve section and all mounting and electrical safety switch hardware.

PFC19 Priority Flow Control Upgrade 21 lbs.



TD4 Tie Down Kit

Heavy-Duty forged 1/2" "D" Ring Tie Down Kit, (rated at 12,000 lbs.), makes securing your MAGNATRAC® to a trailer easier than ever before! Includes: 4 bolt on "D" ring welded brackets and all fasteners.

TD4 Tie Down Kit 5 lbs.



Track Shoe Options

NOTE: Track Shoes are **strongly advised** and provide the greatest traction and stiffen "track plates" for working in rock. MAGNATRACS not so equipped will still pull about 80% of crawler's rated drawbar ability, but may damage track plates.

TSO40 Heavy-Duty Grouser Track Shoe Kit

Replaceable, channel-shaped Steel Grouser Shoes provide the ultimate in traction. These all-steel shoes will go through mud and bite into the hardest ground for maximum traction. *(Factory assembly available)*

TSO40 Steel Grouser Track Shoe Kit 115 lbs.



RP72 Heavy-Duty Rubber Pad Kit

Rubber bolt on pads sit inside the TSO40 Grouser Shoe, providing the traction, while protecting asphalt, concrete and other hard surfaces. Rubber durometer reading of 78, high tear and tensile strength, and outstanding abrasion resistance. *(Factory assembly available, must purchase TSO40 Grouser Shoe Kit)*

RP72 Rubber Pad Kit 151 lbs.



3rd Party Attachments

Universal Mounting Hitch & Category 1 Three Point Hitch Attachments

Many companies make 3rd party attachments that will fit our SH44 Speed Hitch & RH65 Category 1 Three Point Rear Hitch. Most are sold through farm implement stores like: Tractor Supply, Tractor Dealerships or Websites. The flow rates, weights and requirements vary depending on each attachment. Please speak with a Struck Product Specialist to verify specific ratings needed to operate your attachment.

- Snow Blowers
- Pallet Forks
- Grapples
- Brush Mowers
- Breakers
- Stump Grinders
- Chippers
- Trenchers
- Sweepers
- Concrete Mixers
- Earth Augers
- Snow Blades
- Log Winches
- Spreaders
- Tillers
- Tree Spades
- Soil Levelers
- Angle Brooms
- Grapple Rakes
- and many more!



3rd Party
Brush Mower

Standard Warranties



Three Year Engine Warranty

3 Year Residential / Commercial use warranty on Honda & Kubota engines. Major component warranty (MCW) only on the Kubota Diesel engine used in the MH8500. Contact us for a list of engine dealers in your area if you need engine warranty service.



Two Year Machine Warranty

2 Year Residential / Commercial use on the MH4900 or MH8500. Excludes 90 day warranty on 12V battery. Just give us a call if you have a warranty issue. *(Extended Warranties available, speak with a Struck Product Specialist for complete details).*

What's the Next Step?

I Have a Few Questions

So you have read every brochure, combed the website for every piece of information you could find, watched our videos so many times you have it memorized, and you still have questions? Give us a call today! No worries, no high pressure sales here...just honest answers to your questions.

Call or Email Us Today!

Toll Free: 1-877-828-8323

Email: sales@struckcorp.com

I'd Like a FREE Quote

If you've decided which MAGNATRAC® and attachments you need, then all you need now is a **FREE no-obligation quote!** This way we double check everything for compatibility and optimum performance. We'll also do a little research and find the best shipping rates for your location.

We offer many shipping options to fit your needs and budget!

- Local Freight Terminals
- Local Businesses
- Home Delivery
- and More!

I'm Ready to Purchase

We accept many payment options: debit and credit cards, cashier's checks, money orders, wire transfers or PayPal are the most common. If you're looking for financing, ask us about Rocket Loans! This finance option is only available on our website. Otherwise, if you're looking for longer term options, take your quote to your local bank or credit union to secure a loan.

Call or Email Us Today!

Toll Free: 1-877-828-8323

Email: sales@struckcorp.com

IMPORTANT: Though the MAGNATRAC MH4900 & MH8500 are offered assembled, it's still the customer's responsibility to provide competent service ability! The servicing can be provided either by a mechanically inclined customer, or by a local mechanic. Customer responsible to find a local mechanic. Loaders, 6-Way Blade, backhoes, rear hitch with PTO and roll-over protective structures (ROPS) are shipped assembled. Some attachments may be on extra pallets. Other attachments and accessories are shipped in an easy-to-assemble "semi-kit" form for lowest cost shipping. We provide manuals & illustrations for complete service and repair so that anyone with reasonable mechanical skill can perform all required service work.



Struck Corp.
PO Box 307
Cedarburg, WI 53012



1-877-828-8323 - phone
struckcorp.com - website
sales@StruckCorp.com - email

