

MAGNATRAC®

MH4900



Operator/Technical Manual

Struck Corp. - Cedarburg, WI 53012

Copyright 2017 C. F. Struck Corp. All rights reserved.

Version 7.17

#1 - PERIODIC MAINTENANCE:

Though periodic maintenance is well covered in the Operator's Manual, it seems that some operators have let some points "slide" and have suffered expensive repairs. In the hopes of saving you from premature failure in the future, due to forgotten maintenance, the following points are brought to your attention!

A) The #1090 Drive Chains (#80 chain) and the #4007 Drive Chains (#60 chain) should be checked for proper tensioning. See "DRIVE CHAIN TENSIONING" in Service section of your Operator Manual for complete instructions.
Failure to inspect, lubricate and properly tension the chains can result in stripped sprocket teeth and extensive repair work.

B) #1212 & #1212L Right & Left Guards, must be periodically removed and cleaned. Located under the crawler, these guards protect the #1090 Chain from being damaged (**see Photo MH-14**).

Due to the varied materials your tractor operates in, there is no specific maintenance schedule for these #1212 Guards. Rather it is up to the operator to gain experience with the use of the Guards and create his own maintenance schedule...the **Guards may require daily removal and cleaning if the tracks are run all day submerged in mud**, or it may be quarterly or yearly maintenance because your tractor is working in a relatively clean environment like grass, dry dirt.

C) Grease is good. Consistent lubrication of all moving joints, like all axles, pins and cylinders, will greatly extend the life of your equipment, with one exception. **The #4007 & #1090 Drive Chains should not be lubricated with a thick or sticky lubricant (like grease) as this will promote the adhesion of abrasive material. However, keeping your drive chains lubricated with chain oil or another factory approved non-sticky lubricant, will stop the chains from binding and causing repairs to the drive sprockets.** Working in water and mud will dry them out. After 200 hours these chains should be adjusted and lubricated.

#2 - CRAWLER OPERATION...Uphill and Downhill:

It can not be repeated too often that you must operate your Track Control handles **slowly** and **smoothly**...they control a hydraulic drive system that can produce literally "tons of physical force".

But in addition, the Track Controls can also produce an opposite force or "resistance to movement" when going up and down hills with heavy loads...in other words, they can provide a dynamic braking action!

EXAMPLE

Potentially, if you are going downhill with a load that exceeds factory recommendations, you may find that your "overload" is actually pushing you downhill faster than the crawler's drive system is propelling you down the hill. Under these circumstances you have basically two steps for safe control of your crawler:

First, slowly release the Track Controls so that they may go to neutral and provide a dynamic braking action. Again, it must be emphasized that you must operate your Track Controls slowly. Remember, you are controlling tons of force, and though significant overload strength has been built into the Controls, you still can do serious damage to your tractor's hydraulic drive by "snapping" the Controls into the neutral position. The act of snapping the Controls to neutral is equivalent to driving your car down the highway at 65 miles per hour and then instantly shifting into reverse!

The **second** step in controlling your crawler is to apply your Parking/Emergency Brake. This is an over-ride braking action used to augment the hydraulic system's dynamic braking effect. Again, to protect your drive system from harmful shock loads, the brakes, like the Track Controls, must be applied with controlled force...never in a snapping action.

SUMMARY

Your crawler should always be operated with forethought, rather than in a series of sudden, and potentially damaging, starts and stops. Always plan your crawler movements so as to eliminate the need for any potentially damaging sudden Track Control or Brake operation. * **NEVER carry or move loads in excess of factory recommendations!** *

***** As always, you are encouraged to contact the factory if you have any questions regarding the above instructions, or for more information regarding other maintenance and operational procedures!

LIMITED WARRANTY

NEW STRUCK CRAWLERS and/or ATTACHMENTS

(Effective with shipments made after August 1st, 2017)

A. GENERAL PROVISIONS

C.F. Struck Corp. will repair or replace, at its option, for the original purchaser of a new Struck Crawler and/or Attachment, any covered part or parts found upon examination at our factory in Cedarburg, Wisconsin, to be defective in material or workmanship or both; this is the exclusive remedy. Warranty service must be performed by the C. F. Struck Corp. at their factory in Cedarburg, Wisconsin 53012. Warranty service will be performed without charge for parts or labor. The purchaser will be responsible, however, for transportation charges to and from the factory.

B. WHAT IS WARRANTED

All parts of any new Struck Crawler and/or Attachment are warranted for two (2) years, with the following exceptions: Belts, which are warranted for 90 days (excludes normal wear and tear); Engines, which are warranted by their manufacturer; and Batteries, which are provided on a complimentary basis and carry no warranty whatsoever. C. F. Struck Corp. reserves the right to make product design and specification changes without notice and without obligation on their part to present product owners. The Warranty term begins on the date the product is shipped to the purchaser.

C. WHAT IS NOT WARRANTED

(1) Used Products; (2) Any product that has been altered or modified in ways not approved by C. F. Struck Corp.; (3) Depreciation or damage caused by normal wear, lack of reasonable and proper maintenance, failure to follow the product's Operator's/Technical Manual instructions, failure to upgrade crawler with parts furnished at no charge, misuse, lack of proper protection during storage, or accident (4) Normal maintenance parts and service; (5) Use of Struck Crawler and/or Attachments in certain industrial-type applications may affect Warranty coverage.

D. RETURNS AND REFUNDS

In the event of defective materials or workmanship the purchaser agrees to allow C.F. Struck Corp the opportunity to correct the defect in a timely manner at the expense of C.F. Struck Corp. It is at the discretion of C.F. Struck Corp to either correct the defect or refund the purchaser.

To return a Struck Crawler and/or attachment for reasons other than defect the purchaser will be financially responsible for an 8% restocking fee, and for shipping the Struck Crawler and/or Attachment to the C.F Struck Corp. factory in Cedarburg, Wisconsin 53012. No Returns after 90 days.

E. SECURING WARRANTY SERVICE

To secure Warranty service, the purchaser must:

- (1) Report the product defect to the factory in Cedarburg, Wisconsin 1-262-377-3300 or 1-877-828-8323.
- (2) Make the part available to the factory in a reasonable period of time.

F. LIMITATION OF IMPLIED WARRANTIES AND OTHER REMEDIES

To the extent permitted by law, neither C. F. Struck Corp. nor any company affiliated with it makes any Warranties, representations or promises as to the quality, performance or freedom from defect of the products covered by this Warranty. IMPLIED WARRANTIES OF MERCHANTABILITY AND FITNESS FOR A PARTICULAR PURPOSE, TO THE EXTENT APPLICABLE, SHALL BE LIMITED IN DURATION TO THE APPLICABLE PERIOD OF WARRANTY SET FORTH ON THIS PAGE. THE PURCHASER'S ONLY REMEDIES IN CONNECTION WITH BREACH OR PERFORMANCE OF ANY WARRANTY ON C. F. STRUCK CORP. PRODUCTS ARE THOSE SET FORTH ON THIS PAGE. IN NO EVENT WILL C. F. STRUCK CORP. OR ANY COMPANY AFFILIATED WITH IT BE LIABLE FOR INCIDENTAL OR CONSEQUENTIAL DAMAGES.

(Note: Some states do not allow limitations on how long an implied Warranty lasts or the exclusion or limitation of incidental or consequential damages so the above limitations and exclusions may not apply to you.) This Warranty gives you specific legal rights, and you may also have other rights which vary from state to state.

G. ASSEMBLY RESPONSIBILITY

Though the MAGNATRAC RS1000, MH4900 and MH8000 are offered completely assembled, it's still the customer's responsibility to provide competent service ability! The servicing can be provided either by the mechanically customer, or by a local mechanic. All Attachments and accessories are shipped in easy-to-assemble "semi-kit" form for lowest cost shipping. We provide Manuals and Illustrations for complete service and repair so that anyone with reasonable mechanical skill can preform all required service work. Check the MAGNATRAC Specifications & Ratings (in Spec Book or Buyer's Guide) for a list of all standard features.

I hereby accept the terms and conditions of Warranty described above:

print name

signature

date

RS1000
MH4900
MH8000
Warranty 8.1.17

TABLE OF CONTENTS

1- TO THE OPERATOR	1
Recognize Safety Information	1
Understand Signal Words	1
Follow Safety Instructions	1
Service Records	2
2- SAFETY RULES	3
Safety Before Starting or Operating	3
Operation Safety	3
Service Safety	4
Fire Prevention Maintenance	4
Protection From Noise	5
Avoid High-Pressure Fluids	5
Install & Maintain ROPS Properly	5
Start Engine From Operator Seat Only	5
3- CONTROLS AND INSTRUMENTS	6
4- OPERATION	10
Pre-Starting Inspection	10
Prepare For Engine Starting	11
Starting the Engine	11
Warm-up Period	11
Use Seat Belt	11
Traveling	11
Parking Crawler	12
5- FUELS AND LUBRICANTS	13
6- LUBRICATION AND PERIODIC SERVICE	14
Hour Meter (If equipped)	14
Lubrication and Service Intervals	14
Periodic Service Chart	14
7- SERVICE	16
Engine	16
Starter	16
Battery	16
#000441 Interlock Switches	17
Safety Circuit Test	18
Seat Weight Adjustment	18
Drive Chain Tensioning	19
Parking/Emergency Brake	22
Track Maintenance	23
Sprocket & Idler Lubrication	27
Track Idler Maintenance	28
Track Shoes	28
8- TROUBLE SHOOTING	29
9- OPERATING TIPS & PROCEDURES	32
10- PART LIST & PHOTOS	51
Part List	51
Photos	59

IMPORTANT: *Though the MAGNATRAC is offered completely assembled, it's still the customer's responsibility to provide competent service ability! The servicing can be provided either by the mechanically-inclined customer, or by a local mechanic. We provide manuals & drawings for complete service and repair so that anyone with reasonable mechanical skill can perform all required service work.*

1- TO THE OPERATOR

RECOGNIZE SAFETY INFORMATION



This is the safety-alert symbol. When you see this symbol on your Crawler or in this manual, be alert to the potential for personal injury.

UNDERSTAND SIGNAL WORDS

A signal word—**DANGER**, **WARNING**, or **CAUTION**—is used with the safety-alert symbol. **DANGER** identifies the most serious hazards.

Safety signs with the signal word **DANGER** or **WARNING** are typically near specific hazards.

General precautions are listed on **CAUTION** safety signs. **CAUTION** also calls attention to safety messages in this manual.

FOLLOW SAFETY INSTRUCTIONS

Carefully read all safety messages in this manual and on your Crawler and Attachment safety signs. Follow recommended precautions and safe operating practices.

Keep safety signs in good condition. Replace missing or damaged safety decals.

To keep your Crawler running efficiently, read the instructions in this Operator's Manual.

Left side, right side, front, and rear are viewed by facing in the direction of the Crawler's forward travel.

Record your Crawler serial & model numbers in the spaces below. You need this information when you order parts or require technical support.

MAGNATRAC Records

MAGNATRAC Model: _____

MAGNATRAC Serial # _____

Engine Model: _____

Engine Serial # _____

Ship Date: _____

Should questions or concerns arise regarding maintenance, service, or operation of your crawler that are not addressed in this manual please contact the factory by any of the following means.

Mail: **STRUCK CORPORATION**
W51N545 STRUCK LANE
CEDARBURG, WI 53012

Phone*: (262) 377-3300 local
(877) 828-8323 toll-free

Fax: (262) 377-9247

email: techsupport@struckcorp.com

Web: www.struckcorp.com

**For immediate service always call the factory and ask for a technician.*

Maintenance & Service Records

Proper service and maintenance work is critical to trouble free operation of your equipment. It is also critical to diagnosing problems should they arise. Use the space provided on the following page to record maintenance and service work performed.

2- SAFETY RULES

Reports on accidents show that careless use of machinery causes a high percentage of accidents. You can avoid many accidents by following the safety rules on these pages. Study these rules carefully and enforce them on the job.

SAFETY BEFORE STARTING OR OPERATING

- The MAGNATRAC should be operated only by persons approved to do so. 18 yrs or older.
- Clothing worn by the operator should be fairly tight and belted.
- Fasten a first aid kit to the MAGNATRAC.
- Fasten a fire extinguisher to the MAGNATRAC. Keep the extinguisher fully charged. Learn to use it correctly.
- If the MAGNATRAC has an unsafe condition, do not operate. Put a tag on the Track Drive Controls & remove the ignition key.
- Do not start or operate the MAGNATRAC unless you are in the operator's seat.
- Before you start the Engine, be sure there is plenty of ventilation.
- Keep hands, feet, and clothing away from power-driven parts.
- Fasten a slow-moving vehicle sign to the rear of the MAGNATRAC.
- Make sure all hydraulic controls are in neutral before starting.
- Never use auxillary controls without attachment hoses properly connected.
- Do not change attachment control relief valve settings without consulting factory.
- Before you operate Backhoe, be sure stabilizers are in correct position.
- Before you start or operate the MAGNATRAC, clear the area of all persons and obstacles.
- Guards, shields, and other protective devices must be in place and in good condition.



- Before you move any equipment, be sure all persons are away from the Crawler.
- When the MAGNATRAC is operating, **only** the operator should be on it.
- If it is necessary to make checks with the Engine running, **always use two people**...the operator at the controls, should be able to see the person doing the checking.



KEEP HANDS AWAY FROM MOVING PARTS.

DANGER: Never use “quick-disconnect” type couplings on this MAGNATRAC or any of its mating Attachments unless ok’d by the factory; to do so results in the potential of rupturing hydraulic fittings or even “blowing-up” your hydraulic pumps!

BEFORE YOU GET OFF THE MAGNATRAC:

- 1) Move Track Drive Controls to neutral.
- 2) Push down Parking Brake and Pull Up on Lock.
- 3) Lower all equipment to the ground.
- 4) Stop Engine and remove the key.

SERVICE SAFETY

- Be sure you understand a service procedure before you work on the M A G N A - TRAC.
- Unauthorized modifications to the MAGNATRAC may impair the function and/or safety and affect the life of the unit.
- Do not work under raised equipment unless it is correctly supported.

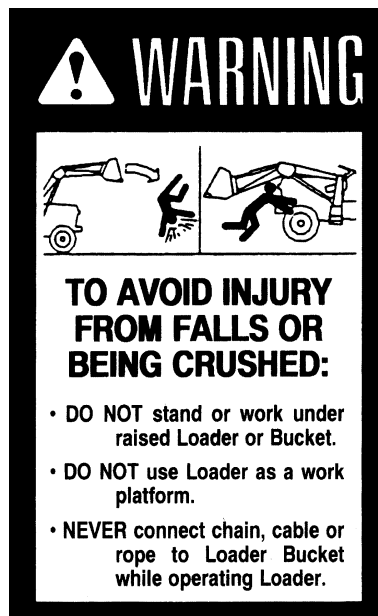

- Before you work on the Engine or electrical system, disconnect the battery’s “ground” (-) terminal first! When work is finished, connect battery’s “ground” terminal (-) last.
- When driving connecting pins, wear goggles or safety glasses.
- Do not run Engine while working on the Crawler.
- Be careful when handling any type of fuel. Do not smoke while filling the fuel tank or working on the fuel system.
- Check for faulty wiring or loose connections.
- Do not lubricate or work on the MAGNATRAC while it is moving.
- Release hydraulic pressure before working on hydraulic system. Move **every** hydraulic control lever back & forth until equipment does not move.
- Before using the hydraulic system, be sure that all connections are tight and that lines are in good condition.
- When you work near the Track Springs, **use extreme care**. Do not disassemble parts unless you know the correct procedure and have correct tools.

FIRE PREVENTION MAINTENANCE

- Be prepared if an accident or fire should occur. Know where the first aid kit and the fire extinguishers are located—know how to use them. Check fire extinguisher for correct charge.
- Do not smoke while refueling or handling highly flammable material.
- Shut off the Engine when refueling.
- Use care in refueling if the Engine is hot.
- Do not use open pans of gasoline or diesel fuel for cleaning parts. Use good commercial, nonflammable solvents.
- Provide adequate ventilation when charging battery.
- Do not check battery charge by placing metal objects across the posts.
- Do not allow sparks or an open flame near battery. Do not smoke near battery.

- Never use an open flame to look for leaks anywhere on the equipment.
- Never use an open flame as light anywhere on or around the equipment.
- When preparing Engine for storage, remember that inhibitor is volatile and therefore dangerous. Seal and tape openings after adding the inhibitor. Keep container tightly closed when not in use.
- Inspect electrical wiring for worn or frayed insulation. Install new wiring if wires are damaged.
- Temperature in Engine and cooling compartments may go up immediately after you stop the Engine. **Be on guard for fires.**
- Before you clean trash from the Engine compartment, wait until the Engine has cooled. Open Side Panels to cool the Engine faster. While the Engine cools, clean trash from other areas.
- Check for leaking fuel lines, hydraulic lines, hoses, or fittings with a piece of cardboard or wood. Do not use your hands. Tighten loose fittings. If lines are bent or hoses kinked, install new parts.

PROTECT AGAINST NOISE

Prolonged exposure to loud noise can cause impairment or loss of hearing. Wear a suitable hearing protective device such as earmuffs or earplugs to protect against objectionable or uncomfortable loud noise.

AVOID HIGH-PRESSURE FLUIDS

Escaping fluid under pressure can penetrate the skin causing serious injury. Relieve pressure before disconnecting hydraulic or other lines. Tighten all connections before applying pressure. Keep hands and body away from pinholes and nozzles which eject fluids under high pressure. Use a piece of cardboard or paper to search for leaks. Do not use your hand.

If ANY fluid is injected into the skin, it must be surgically removed within a few hours by a doctor familiar with this type of injury or gangrene may result.

INSTALL AND MAINTAIN ROPS PROPERLY

If Roll-Over Protective Equipment is loosened or removed for any reason, make certain all parts are reinstalled correctly. Tighten mounting bolts to proper torque. The protection offered by ROPS will be impaired if the ROPS is subject to structural damage, has been involved in an overturn incident or is in any-way altered. Damaged ROPS should be replaced, not reused.

- **DO** use your Seat Belt if your MAGNATRAC has a Roll-Over Protective Structure (ROPS).
- **DO NOT** use a Seat Belt if your MAGNATRAC does not have a ROPS.

START ENGINE ONLY FROM THE OPERATOR'S SEAT!

- Avoid possible injury or death from MAGNATRAC runaway.
- Do not start Engine by shorting across starter solenoid terminals. MAGNATRAC may start and move if normal circuitry is bypassed.
- **Never** start Engine while standing on ground. Start Engine only from operator's seat, with Parking Brake engaged.
- Inspect your MAGNATRAC carefully each day before you start it. See "Pre-Start Inspection".
- Clean your Crawler regularly.

 **WARNING:** The Seat Assembly is equipped with an electrical safety switch to prevent starting and operating the MAGNATRAC while not occupying the seat. Disabling this feature creates the potential for severe injury or death. See Chapter 7 - *Seat Weight Adjustment* for test procedures to verify it is operating properly.

ROLL-OVER PROTECTIVE STRUCTURE (ROPS)

To prevent serious injury in the event of tractor tipover:

- Wear Seat Belt.
- Do not jump if tractor tips.
- Avoid crushing of operator.
- Keep this Roll-over Protective Structure in place.
- Replace damaged Protective Structure...don't repair!

Any alterations to this Protective Structure must be approved by the factory!

3- CONTROLS AND INSTRUMENTS

Learn the location and purpose of all controls, instruments, and warning labels.

CONTROLS

- (A) PARKING / EMERGENCY BRAKE
- (B) LEFT TRACK CONTROL
- (C) RIGHT TRACK CONTROL
- (D) BRAKE LOCK / RELEASE HANDLE
- (E) CHOKE CONTROL
- (F) THROTTLE CONTROL
- (G) SEAT SAFETY SWITCH
- (H) IGNITION SWITCH & KEY
- (I) ATTACHMENT CONTROL VALVE
- (J) HYDRAULIC CIRCUIT CONTROL (if equipped)
- (K) HOUR METER (if equipped)
- (L) HYDRAULIC OIL TEMPERATURE
- (M) HYDRAULIC TANK BREATHER / FILLER (under hood)
- (N) UNLEADED GASOLINE TANK
- (O) EOL™ EASY OIL LEVEL SYSTEM
- (P) HYDRAULIC TANK DRAIN (not shown)

MH4900 Controls & Instruments

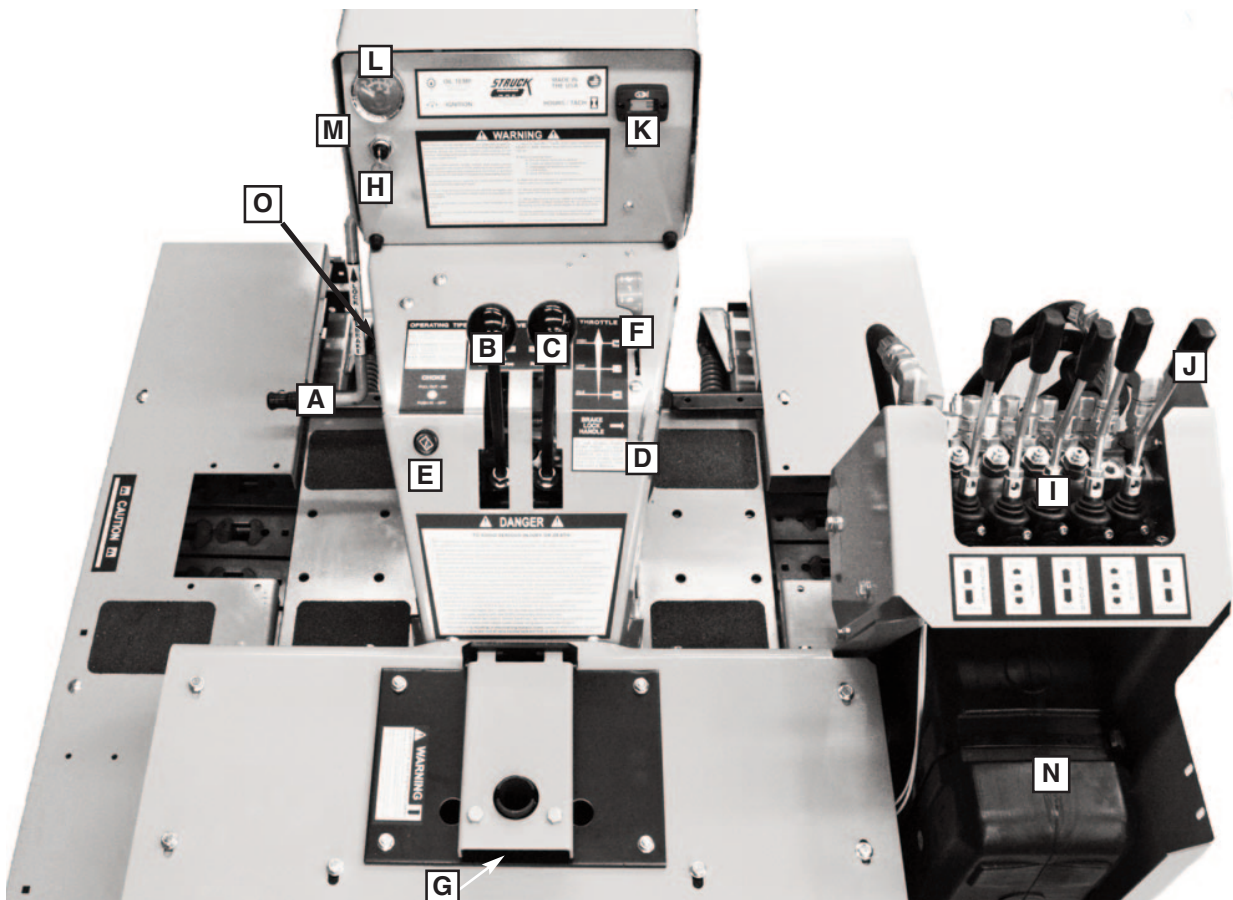

MH4900 Controls & Instruments

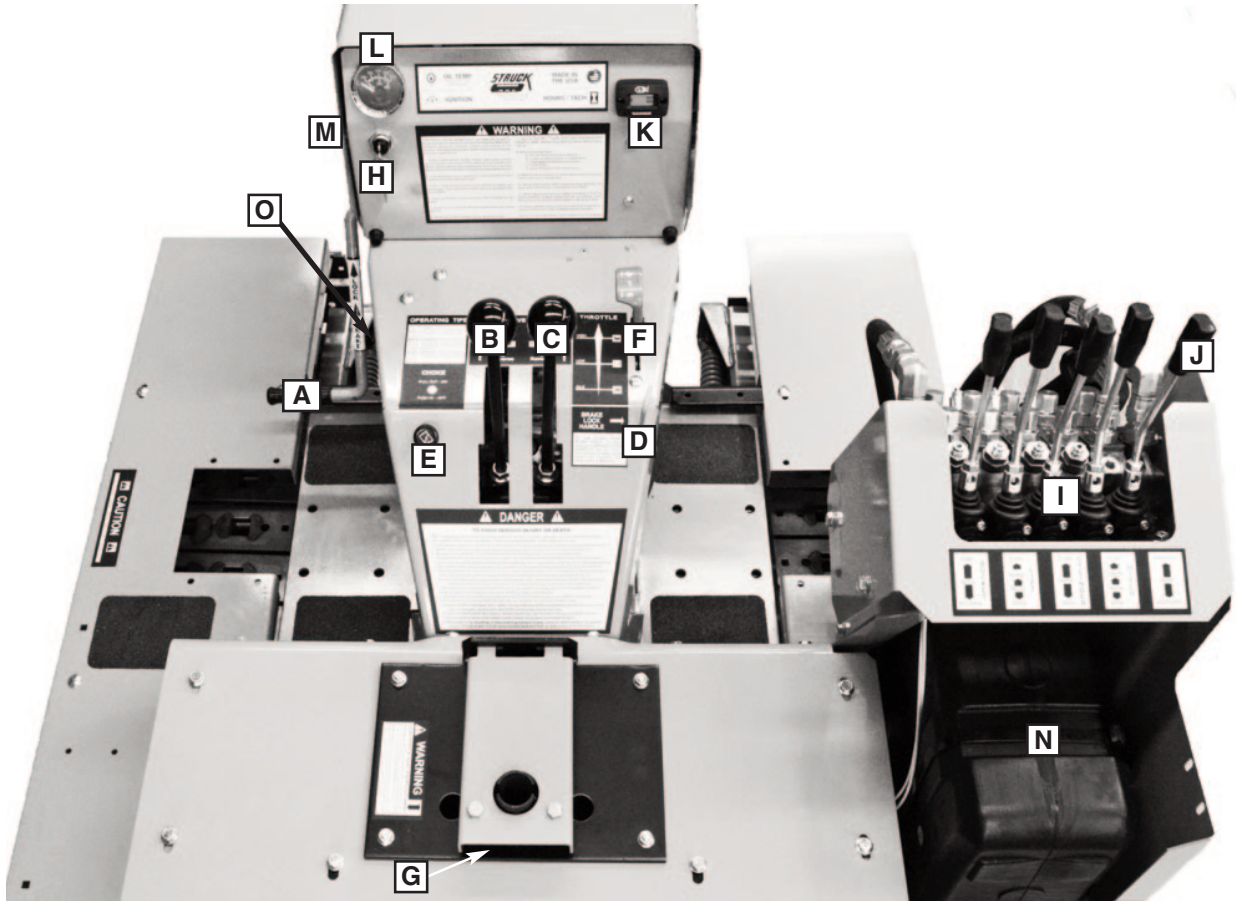

(A) PARKING / EMERGENCY BRAKE

Apply Brake by pushing forward on its pedal with left foot.

To lock brake lift up on Brake Lock/Release handle while Pedal (A) is fully depressed.

To release Parking brake push forward on Pedal (A) until Brake lock/Release handle drops or push down on (D) Brake Release Handle.



(B) LEFT and (C) RIGHT TRACK CONTROLS

- 1) To move straight ahead, push both Left and Right Track Controls forward.
- 2) To move straight rearward, pull both Left and Right Track Controls rearward.
- 3) To turn right, push forward on Left Track Control.

- 4) To turn left, push forward on Right Track Control.

- 5) To counter-rotate Tracks (shortest turn possible), push one Track Control forward while simultaneously pulling rearward on the other Track Control.

NOTE: When either Track Control lever is released, it will automatically return to neutral.

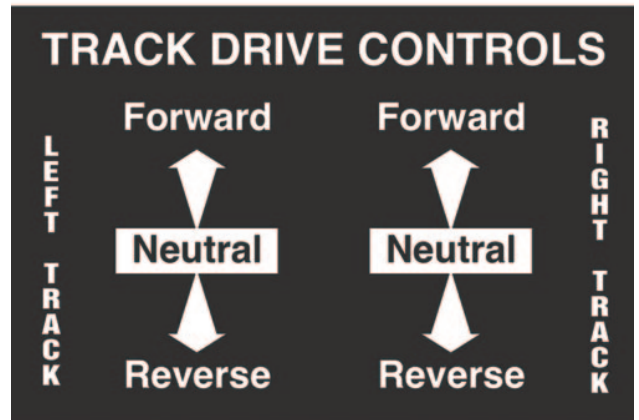

(D) BRAKE LOCK HANDLE

To release Brake, apply foot pressure to Brake Pedal (A) and lower Brake Lock Handle (D); slowly release foot pressure and allow Brake Pedal to come rearward to its natural unbraked position.



To set brake: Press Brake Pedal forward and pull BRAKE LOCK HANDLE up to "set". To unlock brake: push down on handle. See Operator's Manual.

(E) CHOKE CONTROL

Pull to open engine choke, push to close, once started.

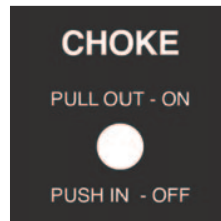

(F) THROTTLE CONTROL

Push throttle control handle AWAY from operator to increase Engine speed & Power.

FOR MAX POWER: Push throttle control to HIGH position and push track drive controls AWAY from operator at about 1/4 to 1/2 way forward.

FOR MAX SPEED: Push throttle control to HIGH position and push track drive controls AWAY from operator fully forward.

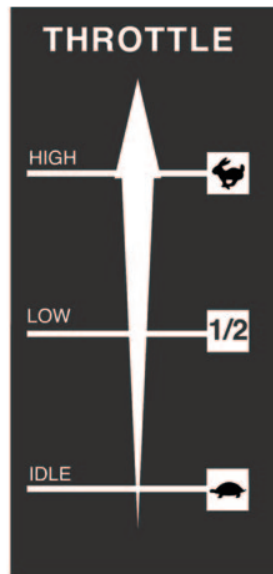

(G) SEAT SAFETY SWITCH

The seat safety switch prevents operation of the MAGNATRAC when the operator is not positioned in the seat. **The safety switch may need to be**

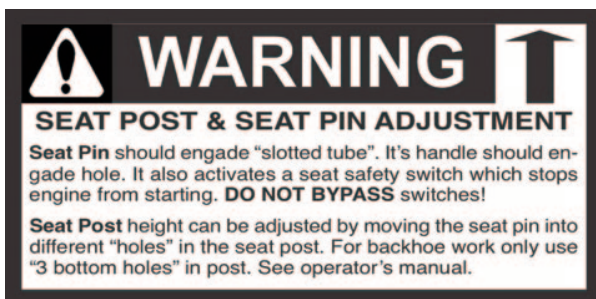

adjusted to the operator's weight in order to operate correctly. For backhoe work only use "three bottom holes" in post. See the Service section of this manual for adjustment procedures.

(H) IGNITION SWITCH

Switch is activated by rotating key clockwise. Turning it fully clockwise will engage Engine starter ... release key and it will return to the Run position. Turn fully counter-clockwise to Off position to stop Engine. Remove key.



(I) ATTACHMENT CONTROL VALVE

A bank of Control Valves is located to the operator's right. These valves are used to control all attachments on your tractor. Your MAGNATRAC will contain from three to five of these valves based on the attachments you have. (Shown below are the 6-Way Blade Controls.)

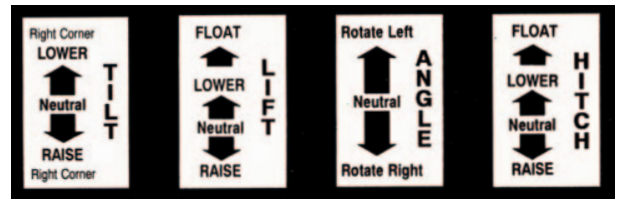

(J) HYDRAULIC CIRCUIT CONTROL (if equipped)

FRONT & REAR AUXILIARY CONTROLS - Never start unit with handle in aux. position!

1) When pushed fully forward and "locked" into the **Auxiliary - 1** position, it directs the oil flow to optional 3rd party attachments like mini-skid steer rated attachments. Contact our Technical Support Dept. for more information on specific hydraulic flow rates, pressures and various uses for this Auxiliary setting.

2) When pulled fully rearward and "locked" into the **Auxiliary - 2** position, it directs the oil flow to optional rear attachments like the Backhoe or Hydraulic PTO. Contact our Tech Support Dept. for more information on specific hydraulic flow rates, pressures and various uses for this Auxiliary setting.

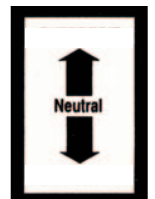

(K) HOUR METER / TACH

Hour meter will record time only when the MAGNATRAC is in use.

The hour meter is also a tachometer.

HOURS / TACH



The tach measures your engine speed (rpm). This can be used to diagnose engine issues and to regulate consistent power for your tracks and attachments, through the hand throttle.

(L) TEMPERATURE GAUGE

This gauge records the hydraulic oil temperature just as it exits the hydraulic tank. Monitor this temperature so that it **does not exceed 180 degrees** Fahrenheit.

If the oil temperature exceeds 180 degrees, stop operating the MAGNATRAC, but allow the

Engine to operate at medium speed to circulate the oil through the oil cooler and lower its' temperature.



OIL TEMP.
KEEP HYD. OIL
BELOW 180°

(M) HYDRAULIC TANK FILL AND BREATHER

The breather removes any air from the hydraulic system. (**Located under the hood, close to the battery**). To fill, use crescent wrench and turn black plastic nut left to loosen. Once fully loose: the breather along with the black, threaded plastic "neck" will be removed.



Fill tank to correct level. See (O) EOL Easy Oil Level System. To tighten, lightly thread the black plastic nut back onto the pipe thread and hand thread. Tighten with crescent

wrench to 1/2 way down the "neck" of the thread.



(N) FUEL TANK

EPA, CARB approved, plastic 5+ gallon fuel tank, with fuel gauge and protective steel guard. (not shown) Unleaded gasoline only. Fuel shut off at the bottom of the tank. (See Picture)



See engine owner's manual for recommended gasoline octane.



(O) EOL™ Easy Oil Level System (not shown)

This easy to read hydraulic oil level system (located on the driver's left side of the MAGNATRAC, on the upper frame, by the engine) requires no removal of breather or dipstick when checking level. Just look at the oil level in circle window and if you see hydraulic oil at the very bottom of the window, it is full. **HINT: Use flash light in dark areas.**



(P) HYDRAULIC TANK DRAIN (not shown)

Located on drivers left, on upper frame, underneath seat area. To remove plug, use crescent wrench and turn left to loosen. **HINT: Run MAGNATRAC at low idle for 3 min. to warm fluid. Retract all hydraulic cylinders to push most of the fluid back into the tank.** To tighten plug, use crescent wrench and turn right to tighten.

4- OPERATION

PRE-STARTING INSPECTION

Before you start your MAGNATRAC for the first time each day, perform the following checks:

ENGINE COMPARTMENT

- Check oil level.
- Check air intake system.
- Check fuel filter.
- Remove trash and oil-dirt deposits.

GRILL AND SIDE PANELS

- Remove trash.
- Clean oil cooler fins.

TRACKS, ATTACHMENTS, SHEET METAL

- Check for bent, broken, or missing parts.
- Check Track springs and tension.

HARDWARE

- Check for loose or missing parts.

ELECTRICAL SYSTEM

- Check for worn or frayed wires or loose connections.

LUBRICATION

- Check lubrication points shown in Periodic Service section of this manual.

GUARDS AND SHIELDS

- Check for tightness and condition.

BATTERY COMPARTMENT

- Remove trash.
- Check cables for tightness and corrosion.

FUEL TANK

- Check fuel level.

HYDRAULIC SYSTEM

- Check for leaking lines and connections.
- Check for bent or kinked lines.
- Check for lines rubbing against each other or against other parts.
- Check oil level.

OPERATOR'S STATION

- Check levers for free movement.
- Check ROPS and Seat Belt.
- Clean floor and instrument panel.
- Adjust Seat to comfortable height for operator.



CAUTION - Before you start the engine:

- 1) Check the condition of the MAGNATRAC. (Pre-start inspection).
- 2) Be sure there is enough ventilation.
- 3) Be sure to know the correct starting and stopping procedure.
- 4) Sit in the operator's seat.
- 5) Clear the work area of people and obstacles.

IMPORTANT: Do not tow or push your MAGNATRAC to start it. You may damage the hydraulic drive system.



PREPARE FOR ENGINE STARTING

- 1) Fasten Seat Belt (only if you have ROPS installed).
- 2) Allow Left (**B**) and Right (**C**) Track Controls to assume their natural spring loaded center neutral positions.
- 3) Push forward on Parking/Emergency Brake (**A**) and/or push down Lock/Release Handle (**D**) until brake unlocks.
- 4) Check that Loader or front-mounted Bulldozer Blade is in the fully lowered position, and that the Backhoe is either in the **chained** safe traveling position, or resting on the ground.
- 5) Check that all other hydraulic controls are in their centered neutral position.

NOTE: The Hydraulic Circuit Controls (**J**) do not have a **spring loaded** neutral centering device; therefore, you must move it back and forth to determine its **center-neutral** position.

- 6) Make sure you are properly seated so Seat Safety Switch will engage.

STARTING THE ENGINE

- 1) Place the Throttle Control (**F**) in the low position.
- 2) Activate the Ignition Switch (**H**) by rotating it clockwise until starter engages. Release the switch as soon as the Engine starts...Switch will return to the Run position.

 **CAUTION:** Do not crank the Engine continuously for more than 10 seconds at a time. If the Engine does not start, allow a 60-second cool-down period between starting attempts. Failure to follow these guidelines can burn out the starter motor.

 **CAUTION:** If the Engine develops sufficient speed to disengage the starter but does not keep running (a “false start”), the Engine rotation must be allowed to come to a complete stop before attempting to restart the Engine.

If the starter is engaged while the flywheel is rotating, the starter pinion and flywheel ring gear may clash, resulting in damage to the starter.

If the starter does not turn the Engine over,

shut off starter immediately. Do not make further attempts to start the Engine until the condition is corrected.

If the battery charge is not sufficient to turn over the engine, recharge the battery.

 **CAUTION:** Do not attempt to jump start the engine with another battery. Starting with batteries larger than those recommended can burn out the starter motor.

WARM-UP PERIOD

1. Run Engine at low or 1/2 speed for 5 minutes.
2. Do not run Engine at fast, or slow idle.
3. Operate MAGNATRAC at less-than-normal loads and speeds for the first 15 minutes.

 **WARNING: Lethal Exhaust Gases**

Engine exhaust gases contain poisonous carbon monoxide. Avoid inhaling fumes, and never run the Engine in a closed building or confined area.

NOTE: Assembled MAGNATRACS are “run in” under no load at the factory for 10 - 15 minutes to properly break-in their drive train and track drive motors, and to test hydraulic systems.

USE SEAT BELT

 **CAUTION:** Use a Seat Belt when you operate with a Roll-Over Protective Structure (ROPS) to minimize chance of injury from an accident such as an overturn.

Do not use a Seat Belt if operating without a ROPS.

TRAVELING

Push forward on Parking Brake (**A**) and lower Brake Lock (**D**); slowly release pressure on Parking Brake and allow it to come back to its natural “rearward” position...remove foot from Brake!

Raise all attachments to their recommended traveling heights.

- 1) **To move straight ahead**, simultaneously push Right Track Control (**C**) and Left Track Control (**B**) forward.

- 2) **To move straight to the rear**, simultaneously pull both Right and Left Track Controls rearward.
- 3) **To turn to the right**, push Left Track Control forward.
- 4) **To turn to the left**, push Right Track Control forward.
- 5) **To counter-rotate Tracks**, (shortest turn possible), push one Track Control forward while simultaneously pulling rearward on the other Track Control.

NOTE: The Right and Left Track Controls are of the self-centering (neutral) “deadman” type. This allows you to simply let go of both Track Controls to disconnect active power to the Tracks.

- 6) **Parking/Emergency Brake (A)** will stop or hold MAGNATRAC in the neutral drive position.

PARKING THE MAGNATRAC

- 1) Lower all equipment to the ground.
- 2) Allow Right and Left Track Controls to go to neutral.
- 3) Push forward on Brake and lift lock handle to engage parking brake.
- 4) Run Engine at LOW OR 1/2 speed 2 minutes without load.
- 5) Move Throttle Control to idle.
- 6) Turn Ignition Switch to Off.
- 7) Release hydraulic pressure by “rocking” all hydraulic controls back and forth.

IMPORTANT: If Engine stops under load, remove load. Start Engine immediately. Run 30 seconds at half speed before adding load.

NOTE: If engine stops, you must turn key **Off** before you can start the engine.

IMPORTANT: In freezing weather or for long term storage, park on a rubber surface (like track mats) or on a sheet of plywood to avoid freezing the Tracks to the ground. If Tracks are frozen to the ground, be careful to avoid damage to the Tracks and drive train when you try to move the MAGNATRAC. When storing your tractor for an extended period of time, make sure to store



it away from any moisture. Moisture in contact with the steel tracks over an extended period of time will rust. Lubricate the drive chains as specified in this manual.

CAUTION: When you park your MAGNATRAC on a slope, put blocks against tracks. **Do not** park MAGNATRAC with tracks pointed downhill.

5- FUELS and LUBRICANTS

FUELS

FUEL SPECIFICATIONS

Check enclosed Engine Owner's Manual and closely follow their recommendations.



FILLING FUEL TANK

The Fuel Tank (**N**) is located to the right of the operator's seat. It is filled by removing the 3" dia. Cap marked with the universal Gasoline symbol (shown at left). Use fuel grade per Engine Owner's Manual shipped with your MAGNATRAC... tighten Cap securely when finished filling.



CAUTION: DO NOT confuse the Fuel Tank (**N**) with the Hydraulic Oil Tank which is filled by removing the #616 (**M**) Breather Cap from the Coupling, underneath the hood, behind the dash.

Fill Fuel tank at end of each day's operation.

Fuel tank capacity is approximately 5 U.S. gallons.

CAUTION: Handle fuel carefully. Do not fill fuel tank when the Engine is running. Do not smoke while you fill fuel tank or work on fuel system.

STORING FUELS

Keep fuel in a container in a protected area. Water and sediment must be removed before fuel gets to the Engine. Do not depend on fuel filters to remove water.

If possible, install a water separator at the storage tank outlet.

Store fuel drums on their sides with plugs up.

IMPORTANT: Keep all dirt, scale, water, or other foreign matter out of fuel.

LUBRICANTS

ENGINE OIL

Check enclosed Engine Owner's Manual and closely follow their recommendations.

HYDRAULIC OIL

Use a premium quality hydraulic oil with maximum anti-wear properties, rust and oxidation treatment. A high quality antiwear hydraulic fluid designed for use in high pressure, high speed hydraulic pumps in industrial hydraulic systems. We use a Megaflo **AW32 Hydraulic Oil 32**. (ISO V632). 10 Weight. Product Code: 1055927. **An ISO of 32 is good for "oil" temperature conditions of +5F to +170F which are considered standard.**

If the above specifications can not be found consult with a local tractor/equipment dealership or oil supplier for other brands of hydraulic oil suitable for loaders, backhoe, and hydraulic drive systems.

Fill Hydraulic Oil Tank through #616 breather (**M**) underneath the hood, behind the Dash, check level with EOL™ Easy Oil Level System (**O**) ...remove Breather with a wrench before filling!

Approximately 12.5 gallons of hydraulic fluid fills the hydraulic reservoir to the proper level.

GREASE

Use premium quality SAE Multi-Purpose Grease for lubricating grease zerks throughout the MAGNATRACS pivot points.

DRIVE CHAIN OIL

Use premium quality SAE Multi-Purpose CHAIN oil for lubricating drive chains. (DO NOT USE GREASE as this will adhere abrasive material to your drive chains.)

6- LUBRICATION and PERIODIC SERVICE

HOURLY METER (if equipped)

Use the Hour Meter (K) to determine when periodic services are required. Should the hour meter not be installed, keep a usage log for your equipment to maintain service intervals.

LUBRICATION AND SERVICE INTERVALS

IMPORTANT: Recommended service intervals are for normal conditions. Service more often if Crawler is operated under difficult conditions. Such as extreme heat, dusty conditions, and daily use for extended period of time.

IMPORTANT: Use only quality lubricants at intervals specified in this manual.

PERIODIC SERVICE CHART

Air Cleaner(s) - Service per instructions in Engine Owner's Manual.

Engine Oil - Service per instructions in Engine Owner's Manual

Battery - Change as needed. Approximately every 3 years.

1ST USAGE

Hydraulic Oil - Attach any additional attachments first (Grapple, backhoe, 3 pt. hitch, etc.) Check level on a flat & level surface; with equipment on the ground (retract all possible cylinders), level should be showing in the window of the EOL™ Easy Oil Level System. Add additional fluid if needed.

Engine Oil - Check engine oil level before use to make sure oil level is at acceptable level on the dipstick. Add additional if needed.

Fuel - Add fuel to fuel tank per engine manual specs. **Unleaded 86 octane or higher** is recommended per HONDA. Verify fuel shut-off valve is in the open position.

EVERY TEN HOURS

Grease Fittings - Lubricate all grease fittings per location instructions in manual of each attachment you have mounted on your MAGNATRAC. Recommended grease: **Multipurpose NLGI 2 Grade Lithium Complex, ISO VG 220.**

A small breakdown of how many grease fittings are on the MH4900 and various Attachments is as follows:

MH4900: 14 (w/TSU551 Upgrade)

MH4900: 10 (standard equipment)

For a MH4900, all grease fittings will be on the outside of every idler axle, except for the Front Idler axle. On the Front Idler axle, it is on the *inside end* of the welded tube. **Hint: You may have to rotate the tracks to find these grease fittings. (See Photo MH-37)**

For all others, please see each individual attachment for the quantity of grease fittings. As a standard guide, there will be a grease zerk for each Axle/Pin that you see on a particular attachment. (See below).

HL900 Loader:	12
SWB54 6-Way Blade:	7
D108 Backhoe:	21
D1065 Backhoe:	18
RH65 Rear Hitch:	5
BG48 Brush Grapple:	2
CK29 Cylinder Kit:	2

Oil Cooler - With *low pressure* air, blow clean the "fins" of the oil cooler.

Fittings & Hoses - Check hydraulic fittings and hydraulic hoses for cracks, breaks, and leaks.

General Once-Over - Check for loose nuts and bolts and any signs of premature wear. Correct any problems immediately. **NOTE:** Check "NOTE" in **Service Section** of this manual for information on Track Idler wear!

EVERY FIFTY HOURS

Filters & Engine Oil - **HINT:** Write the date and # of hours on all filters to remember when to change in the future!

- A) Replace **Engine Oil Filter** & drain and replace **Engine Oil** with filter type recommended in Engine Owner's Manual. (See **Photo MH-10 & MH-12**)
- B) Replace **Engine Air Filter** with filter recommended in Engine Owner's Manual. (See **Photo MH-10**)
- C) Replace **Hydraulic Oil Filter** with a new Canister. (See **Photo MH-18 & MH-19**)
- D) Replace **Engine Fuel Filter** for dirt; if showing sediment, replace with new. (See **Photo MH-10**)

Track Tension - Maintain overall tightness of each track. When your tractor leaves our factory, the outside, black, **#234 Spring measurement is 4 1/2 in. The inside yellow, #233 Spring measurement WILL NOT be the same!** The most important thing is for the front axle to be square. In addition, check that the #235 Washer against the *front face* of each #215 Front Axle is not loose enough to be rotated with fingers. Check **Service section** of this manual for complete explanation and Track tensioning procedures. (See **Photo MH-38**)

Drive Chain Lubricating - Oil the #4007 (#60) Drive Chain and also the #1090 (#80) Drive chain as well. Working the oil in completely will help the chain from binding. Keeping these chains lubricated with chain

oil (**NOT GREASE!**) will greatly extend the life of your parts. Working in water and mud will dry them out. (See **Photos MH-32 and MH-33**)

Remove Lower Chain Guards - Your MAGNATRAC has #1212L and #1212R chain guards to protect the lower #80 drive chains. Although they do protect against rocks and other damaging materials. We do recommend to remove and let any loose material out of them every 50 hours. See Service Section of this manual. (See **Photo MH-40**)

EVERY 200 HOURS

Hydraulic Oil - Run the MAGNATRAC for approx. 5 minutes at idle, shut off. Completely drain system by removing plug in driver's left rear corner on underside of Crawler's Upper Frame. **NOTE:** Drain when fluid is warm; block up the right front corner of Crawler a few inches to get oil to flow completely to drain opening. Refill with approx. 12.5 gallons of hydraulic fluid fill the hydraulic reservoir to the proper level. (See **Photo MH-14**)

Hydraulic Filter - Replace Hydraulic Oil Filter with a new Canister. (See **Photo MH-19**)

Fuel Filter - Replace with new Fuel Filter at this time: Filters can be purchased through the Struck Corporation or through local engine dealers. (See **Photo MH-10**)

Fuel Tank - Remove and drain tank of any water or sediment. (See **Photo MH-16**)

Drive Chain Tension - Maintain chain tension in drive train. Check **Service section** of this manual for complete Drive Chain Tensioning procedures. (See **Photos MH-28 thru MH-35**).

Engine Spark Plugs - Replace **Engine Spark Plugs** with filter recommended in Engine Owner's Manual. (See **Photo MH-10 & MH-12**)

7- SERVICE

ENGINE

Your MAGNATRAC comes with a complete Engine Service Manual. Additional service or owner's manuals for the engine can be found on the HONDA website or through your local HONDA dealer. It provides troubleshooting tips along with complete rebuilding procedures. If further help is needed, contact your local Engine dealer. Search on the the HONDA engine website for a service center nearest you.

NOTE: Should service instructions within this manual conflict with the engine manufacturers service manual then default to the engine manufacturer's manual.

STARTER

IMPORTANT: Do not hold key in start position longer than 10 seconds at a time. If the Engine does not start within 10 seconds, wait 60 seconds before pushing starter button again. After a false start, **do not** turn key to start position until Engine has stopped turning.

If the starter will not operate or operates sluggishly, check for the following:

- 1) Run down battery.
- 2) Dirty, loose, or corroded cables and wires.
- 3) Engine oil viscosity too heavy.

BATTERY

Your MAGNATRAC has a 12 volt, negative-grounded system with one battery.

BATTERY PRECAUTIONS

 **CAUTION:** Sulfuric acid in batteries is a poison and could cause severe burns. Avoid contact with skin, eyes, and clothes. When you work around batteries, protect eyes and face from battery fluid and explosion.

Antidotes for Sulfuric Acid:

EXTERNAL

1. Flush skin well with water.
2. Flush eyes for 15 minutes.

3. Get medical attention immediately.

INTERNAL

1. Drink a large amount of water or milk.
2. Then drink milk of magnesia, beaten eggs, or vegetable oil.
3. Get medical attention immediately.



CAUTION: Keep flames and sparks away from batteries.

Do not use booster cables or adjust post connections unless you know the correct procedure.

When you charge a battery or use a battery in a closed space, be sure there is enough ventilation.

Keep batteries where children cannot reach them.

Keep vent caps tight and level.

COLD WEATHER BATTERY SERVICE

During cold weather, keep electrolyte in battery at correct level. Keep battery fully charged.

BATTERY STORAGE

If MAGNATRAC will be stored for more than 30 days, remove battery. Keep it fully charged.

BATTERY MAINTENANCE

- 1) Remove corrosion from terminals with a stiff brush.
- 2) Clean battery with a baking soda solution (1/4 pound in a quart of water).
- 3) Flush battery and compartment with clear water.
- 4) Check electrolyte level. (If so equipped) Fill each cell to bottom of filler neck with distilled water or clean, soft water (not hard water).
- 5) Put petroleum jelly on terminals. Maintain Protective Cover on "positive" (+) terminal of battery.
- 6) Replace battery approx. every 3 years.

#441 INTERLOCK SWITCHES

Two #441 Switches are used in the MH4900's electrical system as safety devices to detect if the operator is properly seated and that the Parking Brake is engaged **before** the Crawler can start. The **plunger** in each #441 Switch has to be depressed for the Switch to **close** and activate the electrical circuits; the **plunger** has to be released for the switch to **open** and safely deactivate the circuit.

To check either the #441 Seat Switch or the #441 Brake Switch, you must remove the electrical plug attached to each switch's two terminals and connect a continuity tester to its terminals (a simple flashlight type would be fine).

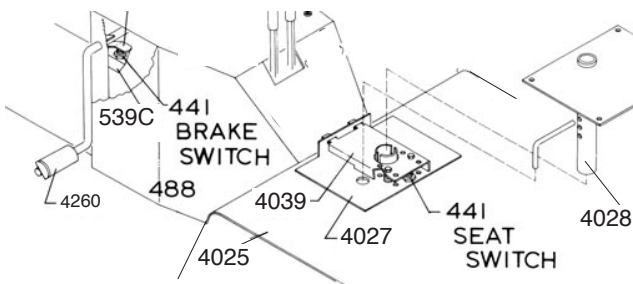

#441 SEAT SWITCH TEST:

NOTE: To make this Test and subsequent adjustments, remove the 5/16" Cap Screws that hold the #4025 Pan in place. Raise the Pan a few inches and reach underneath to remove the electrical plug attached to the #441 Seat Switch's terminals. With Plug removed, the Pan can be fully raised and removed for the following tests and adjustments.

A. With the #4039 (I) Treadle resting **flat** on #4027 Seat Plate, the #441 Seat Switch should be **closed**. A continuity tester, attached to the terminals of the Switch, should have its light on at this time!

B. With the #4039 (I) Treadle released and allowed to rise to the height permitted by the two **restraining** Cap Screws, the Switch should be **open**; the light should be **off**!

If **both** of the above conditions are not met, you must adjust the height of the #441 Seat Switch. The Switch is secured top and bottom of the #4027 Seat Plate with large hex nuts. Raise

or lower the Switch's height to meet requirements **(A)** and **(B)** in Seat Switch Test (above) by relocating these hex nuts.

When adjustment is completed, tighten both hex nuts. Terminals of Switch should point directly to the left. Remove continuity tester and return #4025 Pan back into position. Replace electrical plug on terminals of Switch and secure Pan with original Cap Screws.

At this time, following recommended safe starting procedures, start the Engine and check Switch's setting... readjust if necessary.

#441 BRAKE SWITCH TEST:

NOTE: For this Test remove the Cap Screws holding the #4048 Left and #4049 Right Side Panels. Remove the electrical plug from the #441 Brake Switch and connect a continuity tester to its two terminals.

A. Push #4260 Brake Pedal forward, lift on the #247 Pull Rod until the #401M Pin drops into the **notch** in the end of the #405 Bar, the #441 Brake Switch should be **closed** (from contact with the rotated #440 Leaf Spring); the light of the continuity tester should be **on**!

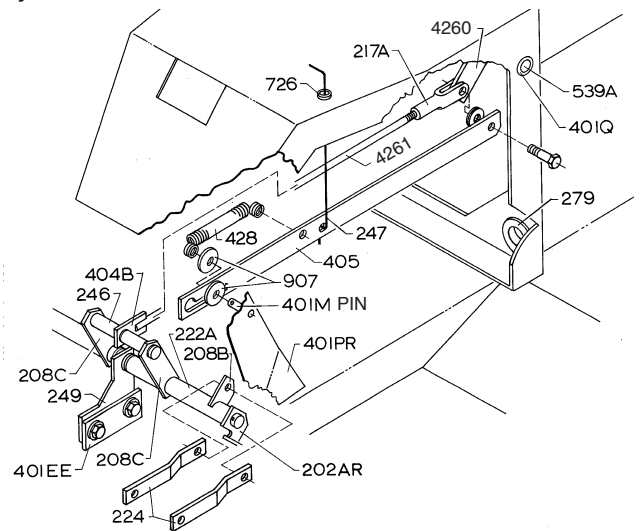

B. Push the Brake Pedal forward to **unlock** and allow it to travel rearward until stopped by the frame pin reaching the forward end of slot in #405 Bar, the #441 Brake Switch should be **open** (the #440 Leaf Spring would have rotated up and away); the light of the continuity tester should now be **off**!

If **both** of the above conditions are not met, you must adjust the height of the #441 Switch.

#440 Leaf Spring would have rotated up and away); the light of the continuity tester should now be **off!**

If **both** of the above conditions are not met, you must adjust the height of the #441 Switch.

The Switch is secured top and bottom of the #539C Bracket with large hex nuts. Raise or lower the Switch's height to meet requirements (A) and (B) in Brake Switch Test (above) by relocating these hex nuts. When adjustment is completed, tighten both hex nuts...terminals of Switch should point directly to the right. Remove continuity tester and replace electrical plug on terminals of Switch. Replace Left and Right Side Panels.

At this time, following recommended safe starting procedures, start the Engine and check Switch's setting...readjust if necessary.

SAFETY CIRCUIT TEST

The Safety Circuit is an electronic method to sense **safe starting** and **safe operating** conditions. The Circuit performs its **safe start** function by sensing the condition of the Seat Switch and Brake Switch. The Brake circuit switch must be closed in order for the engine to crank. The seat switch must be closed in order for the engine to turn over and run.

The **safe stop** function is accomplished by sensing the condition of the Seat Switch. Once the Engine is started, the operator must remain seated thereby keeping the Seat Switch **closed** or the Engine will shut down.

An added safety feature is its **closed to operate** function which ensures that the Crawler will not function if the switch leads are broken or become disconnected.

TESTING SAFETY CIRCUIT

Conduct the following tests to check proper functioning of Safety Circuit & related switches:

A. Following recommended safe starting procedures, and with operator seated but Parking Brake not applied, attempt to start Engine. The Engine should not start. If it does, readjust #441 Switch on #539C Bracket; Switch is mounted too high in its Bracket and is closing too soon. If readjustment doesn't solve the problem, test #441 Switch and replace if necessary.

B. Following recommended safe starting procedures, and with Parking Brake **locked** but with operator standing in the operator's compartment (not seated), attempt to start the Engine. The Engine should not start. If it does, readjust #441 Switch on #4027 Mount; it's mounted too **high** in its Mount and is **closing** too soon. If readjustment doesn't solve the problem, test #441 Switch and replace if necessary. Check "expanded" height of #506 Springs (see below).

C. Following safe starting procedures, with Parking Brake **locked** and operator properly seated, start Engine. Engine should start. If not, recheck settings of #441 Switches... Tests (A) and (B) above. Replace Module if necessary or see troubleshooting section of this manual.

SEAT WEIGHT ADJUSTMENT

The weight of the operator required to activate the #441 Seat Switch can be adjusted by moving the pair of #506 Springs back and forth in the three sets of mating 3/8" holes located between #4027 Mount and #4039 Treadle. (See Photo MH-5)

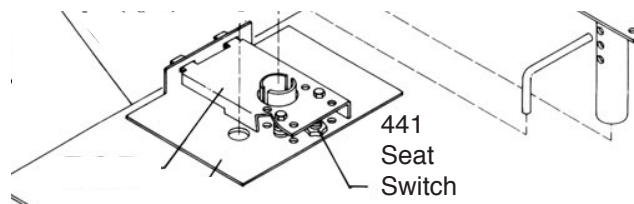

The drawing above shows Springs installed in the "mid-weight" range. Use the set of holes forward for the lighter operator; use the set of holes rearward for the heavier operator.

NOTE: When reassembling the #506 Springs to a new position, tighten each 3/8" Cap Screw such that it will allow each Spring to expand to only 1" high (measure Spring length only).

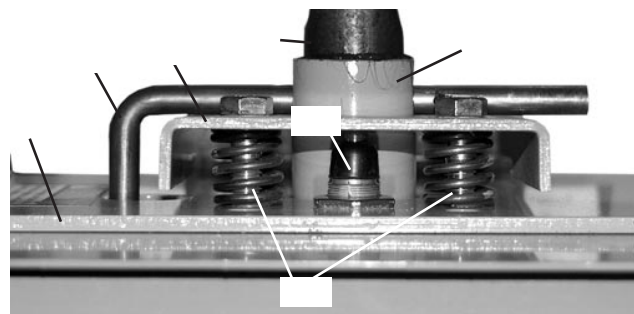

**Reference Photo for
DRIVE CHAIN TENSIONING**

4002R

4200

Loosen Three (3) 3/8" Carriage Bolts on left & right side of #4202R Motor Box... tighten securely after your Chain adjustment.

To Tighten #4007 Chain, you must move #4200 Shaft up to remove slack in Chain:

The #4202R Motor Box pivots on the 1/2 bolts shown.

Only If Necessary:
Loosen two 1/2" Cap Screws holding front end of #4202R Motor Box... tighten securely after your Chain adjustment.

4202R

436

201C

Loosen two 1/2" Machine Bolts

To Tighten #1090 Chain, you must move

1219
OR
4225

Remove #1908 Cotter Pin

1221

232 SHIMS

When Tensioning:
Add equal number of shims above the inner & outer #1211 Axle Supports.

1211

Loosen two (2) 3/8" Carriage Bolts

1210

**Reference Photo for
DRIVE CHAIN TENSIONING**

4002

4007

223

Loosen Three (3) 3/8" Carriage Bolts on left & right side of #4202R Motor Box... tighten securely after your Chain adjustment.

To Tighten #4007 Chain, you must move #223 Shaft *up* to remove slack in Chain:

The #4202R Motor Box pivots on the 1/2 bolts shown.

Only If Necessary:
Loosen two 1/2" Cap Screws holding front end of #4202R Motor Box... tighten securely after your Chain adjustment.

436

4001

201C

Loosen two (2) 1/2" Carriage Bolts

To Tighten #1090 Chain, you must move #214 Axle *down* to remove slack in Chain:

Remove #1908

214

232 SHIMS

1211

Loosen two (2) 3/8" Carriage Bolts

DRIVE CHAIN TENSIONING

(#4007 & 1090 Chains)

Tighten #4007 Drive Chain (#60 roller chain) by increasing the center distance between the **movable** #223 Shaft and the **fixed** #436 Shaft... make this adjustment to both sides of Crawler!



Consult the 2 “reference photos” (above) and part photos MH-28 through MH-35 noted in this Manual to assist in this procedure.

To tighten the #4007 Drive Chain, first remove #4025 Pan (See page 17)...remember to remove the electrical plug from #441 Seat Switch. Loosen the two 3/8” Bolts holding the #249 Support to the

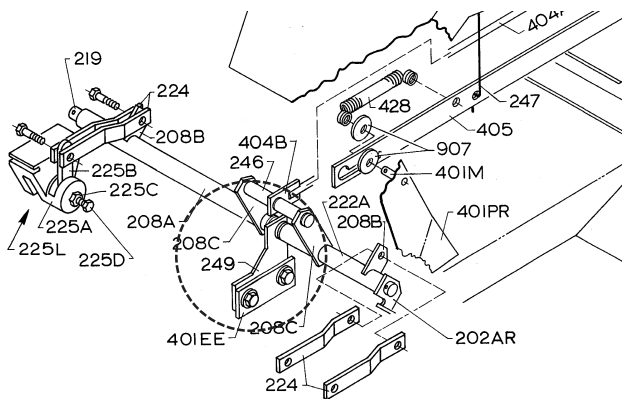

Frame...fully loosen, but don't remove the nuts.

Loosen the **six** 3/8” Carriage Bolts (**three** on the **outside** and **three** on the **inside**) of the #4202 Motor Box. Rotate the Motor Box upward (away from the #201C Box) until the **slack** has been removed from the Chain. NOTE: If the Motor Box does not move up with reasonable “ease” it will be necessary to also “slightly” loosen the two 1/2” Bolts on the front of Box.

Do not make Chain “bow-string” tight. Secure in position by retightening the six 3/8” Carriage Bolts and the two 1/2” Bolts if loosened above. Make this #4007 Drive Chain adjustment on **both** sides of Crawler!

Retighten the two 3/8” Bolts holding the #249 Support to the frame.

Replace #4025 Pan, electrical plug on Seat Switch and then start and operate Crawler. Check Drive Chain adjustment and readjust if necessary.

Tighten #1090 Drive Chain (#80 roller chain) by increasing the center distance between the **mov-**

able #214 Rear Axle and the **fixed** #436 Shaft...do this to both sides of Crawler.



Consult the 2 “reference photos” (above) and part photos MH-28 through MH-35 noted in this Manual to assist in this procedure.

Block Crawler “Lower Frame” from beneath so that Tracks are a few inches above the ground. Loosen and remove the two 1/2” Nuts on the ends of each #1030 Rod. Remove the #233 & 234 Springs and allow the #215 Front Axle to slide back to the end of its slot in the Track Frame. (Part Drawing MH-B).

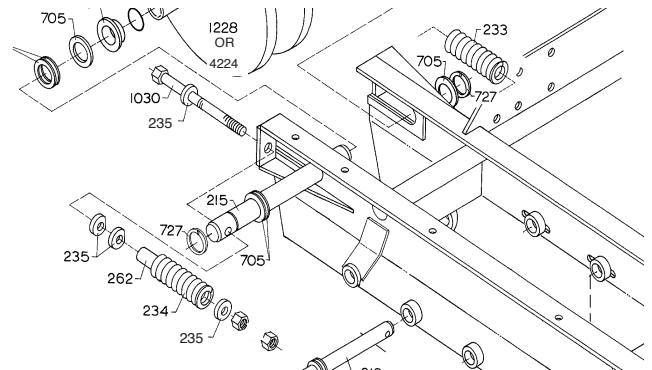

Remove the (3) 5/16” and (1) 1/2” Bolts holding each of the #1212R & #1212L Right & Left Guards mounted to the underside of the Lower Frame... save bolts for later reassembly!

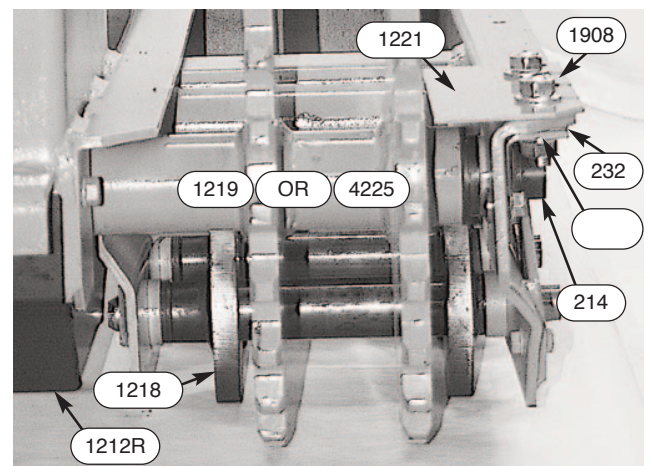

Thoroughly clean the #1212R & #1212L Guards and the interior compartments and roller chains they cover!

Fully loosen the (2) 1/2” Bolts and (2) 3/8” Carriage Bolts and fully remove the #1980 Cotter Pin holding each #1211 Axle Support...fully loosen Bolts so that #214 Rear Axle drops down evenly

Add additional #232 Shims to the existing **pack** of #232 Shims mounted *above* each #1211 Axle Support on each end of #214 Rear Axle. Add Shims until the #1090 Drive Chain is tight...you may lightly **tap** in the last shims but do not **drive** them in (that would indicate you are over-tensioning the Chain). If you've made this adjustment to the point where it doesn't take out the slack; then at this time install a new chain. **DON'T take a link out of the chain!**

NOTE: Add the same number of Shims on *each* end of *each* #214 Rear Axle to make sure the Rear Axle will stay horizontal. Replace #1908 Cotter Pins removed above and secure them. Tighten both 1/2" Bolts that secure each #1211 Axle Support. This tightening step will draw the Shim **packs** tight and create the proper slack in the #1090 Drive Chain.

REMEMBER to make this #1090 Drive Chain Adjustment to both sides of the MAGNATRAC!

Using original Bolts, replace the #1212R & #1212L Guards and tighten. **(See Photo MH-40)**

Follow Track Tensioning procedure in this manual and re-tension both Tracks. Remove MAGNATRAC from blocks and test run. Check Drive Chain adjustment and readjust if necessary.

PARKING/EMERGENCY BRAKE

The Parking/Emergency Brake provides a force approximately equal to the strength of the MAGNATRAC's drive system and is used in a number of ways. One way, is as a Parking Brake. In this capacity, it holds the MAGNATRAC in position when the Engine and drive system is shut off.

In addition, it provides a **safe start mode**, as

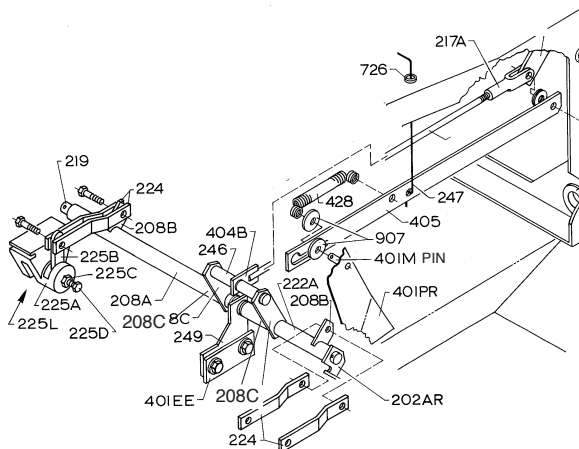

the Brake must be engaged before starting the Engine. If the operator inadvertently touches the Track Drive Controls during Engine starting, the Brake will severely load the drive system and potentially kill the Engine (unless the Track Drive Controls are released immediately).

The Brake's other use is that of an Emergency Brake. If you should ever lose Engine or drive system power, the Brake can be activated instantly to hold the MAGNATRAC safely in position.

DISK BRAKE ADJUSTMENT

CAUTION: Read the following Disk Brake and Disk Puck instructions in their entirety before attempting any Disk Brake adjustments!



Consult the part photos and drawings at the back of tractor manual to assist in this procedure. (Refer to Part Photo MH-6 & 7 and MH-26 though 30).

Release Parking Brake. Unscrew the #225C Jam Nut on #225R & #225L Right & Left Disk Brakes a few turns to release each Jam Nut's respective #225D Threaded Adjuster Pin.

Rotate the Adjuster Pin on each Disk Brake **in** (clockwise when viewing **face** of Brake) until it stops...don't overtighten, just tighten to the point where it stops and the **pucks** (brake linings) are tight on the Brake Disk.

Now counter-rotate (counter-clockwise) the Adjuster Pin of each Disk Brake exactly 180 degrees. The pucks should have lost their grip on their respective Disks and both Brake assemblies should be free to move.

Push forward on the #4260 Parking Brake and watch as each Disk Brakes' #225B Lever begins to rotate forward, and tighten the pucks of each Brake on their respective Disk. The #246 Evener Rod is the **central pull device** that connects the two Disk Brakes together, and it **must be kept parallel** to the #219 Pivot Rod.

If it is not parallel, determine which of the two #208C Levers (connecting the #246 Evener) is further rearward. Release the Brake. Rotate just a few degrees counter-clockwise, the Adjuster Pin of the Disk Brake that is closest to the most rearward #208C Lever. Push forward on Brake and recheck for parallelism of #246 Evener & #219 Pivot...readjust if necessary. When satisfied, hold each #225D Adjuster with wrench and tighten its

⚠ DANGER: The proper adjustment and maintenance of your Disk Brakes can not be overemphasized! Double check your work for safety. Always call our Service Department with any doubts or questions you may have!

Using a Spring Scale attached to #4260 Brake Pedal, pull the Scale fully forward with a force of approximately 90 pounds and lift up on #247 Brake lock handle to lock brake into Parking Brake Position.

At this point, the notch in “slot” in *lower rear* of #405 Bar should lift up and around mating #401M Frame Pin.

If it doesn't, then release “spring pressure” and disconnect 5/16” Cap Screw holding #217A Clevis on forward end of #404 Pull Rod... screw Clevis further *off* Rod. Remount Clevis and check. If notch lifts over Pin before a spring scale reaches 60 pounds, screw Clevis further on Rod and then reassemble and check.

When satisfied, secure 5/16” Cap Screw holding #217A Clevis and #405 Bar with 5/16” Lock Nut. Don't overtighten; Cap Screw must be able to rotate.

Release your Parking Brake by pushing Pedal fully forward until #247 handle drops (it may be necessary to push down on #247 to release brake). and check your final adjustment. It is **mandatory** that when the Brake Pedal is released, that each Disk Brake's **puck** is fully released and the Disk Brake assemblies are free to move without any appreciable **drag** on their respective Disks.

DISK PUCK WEAR

As the Brake System is your highest priority safety device, it is **mandatory** that you compensate for any Puck (brake lining) wear by repeating the DISK BRAKE ADJUSTMENT steps detailed above.

Check with factory Service Department with any questions you may have regarding when and how to replace Brake Pucks (brake linings) or other brake related parts.

TRACK MAINTENANCE

Before attempting to complete any of the three parts of this Track Maintenance section, it is recommended that you read all three parts completely to provide background on how the total Track System is adjusted and maintained.

Below are a series of drawings to aid you in parts identification as you follow the procedures described below. To aid clarity, only the parts described in the instructions are included in most of the drawings. In some cases, to lessen confusion, certain parts (such as Track Rods), do not appear in all drawings.



Consult the part photos and drawings at the back of tractor manual to assist in this procedure. (Refer to Part Photos MH-29 through MH-40).

NOTE: When working with the Tracks, you will be dealing with some significant weights and will be required to hold some specific alignments. Though the Tracks can be successfully put on (and off) by a single person, it's strongly advised to have an able-bodied “helper” available both for

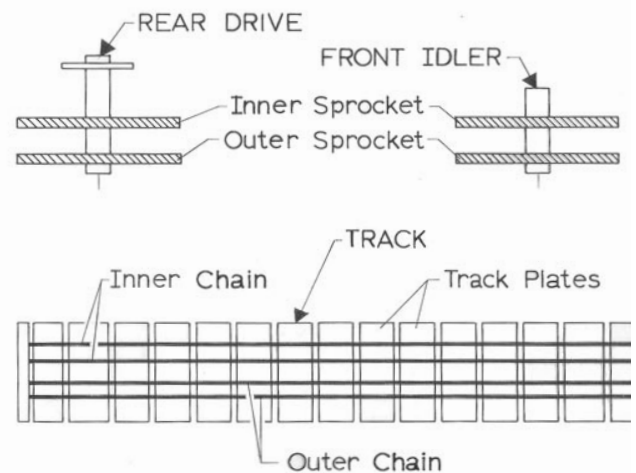

assistance and safety reasons!

TRACK REMOVAL

Drive your MAGNATRAC onto a firm, level surface. Shut off engine and dismount. From below, block the MAGNATRAC so that Tracks clear the ground by 2”. Use solid blocking and place it under the MAGNATRAC so that it will give the Tractor the greatest support left to right and front to rear. When placing your blocking, analyze the total weight and balance of the MAGNATRAC



CAUTION: When blocking the MAGNATRAC, do not put blocks under either Sprocket of either the Rear Drive “assemblies”!

NOTE: As you work with the Tracks, realize that the more you can support the “lower strand” of each Track and keep it flat and close to the center Idler Wheels (4.5” diameter), the more slack you will have in the “upper strand” of the Track to work with!

Remove the #1220 Spring Guard that covers the #234 Spring (black) on the Track you are preparing to remove...save Spin Lock Bolts and Nuts for later reassembly.

Loosen and remove one of the 1/2” Fine thread Nuts from the extreme end of each #001030 Rod that is tensioning the Track you wish to remove.

By rotating each #1030 Rod counter-clockwise, Loosen and remove each remaining 1/2” Nut and #235 Washer and its respective #233 or #234 Spring. Slide #215 Front Axle fully rearward.

With gloved hands begin to rotate the Track **forward**. Remember to periodically “rock” the Track’s Control Handles forward & back to relieve any internal pressure on the Track’s Motor. As the Track is rotated **forward**, insert the #1229 Track Rods (shipped with your MAGNATRAC), between alternate mating teeth of the Front Idler’s Inner & Outer Sprockets...keep Rods centered over their respective Inner & Outer Sprockets. **See Drawing below.**

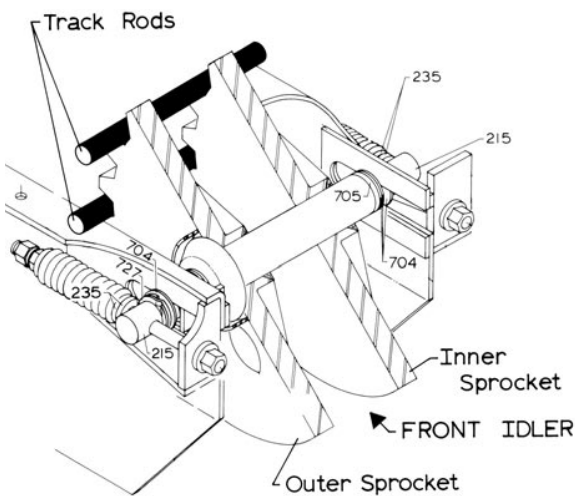

To ease Track rotation, insert the #1521 Lever Rod (shipped with your MAGNATRAC) between two Track Plates and fully engage the Rod’s end on the **bottom** of the tube of the #1228 Front Idler.

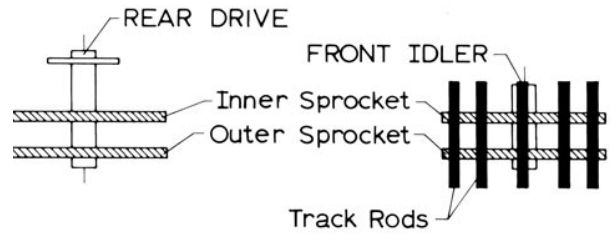

NOTE: Insert the #1521 Lever Rod between Track Plates located at about the 1:00 o’clock position and rotate Lever Rod downward.

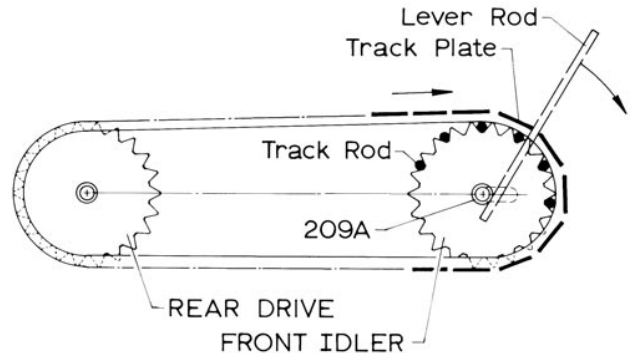

CAUTION: Remember to periodically “rock” the Track’s Control Handle forward & back to relieve any internal pressure on the Track’s Motor.

Depending on the amount of debris in your Track system, you should be able to insert 5 to 6 #1229 Track Rods between the alternate mating teeth of the Front Idler’s Inner & Outer Sprockets...keep Track Rods centered over their respective Inner & Outer Sprockets!

When the last #1229 Track Rod you installed has rotated to the 12:00 o’clock position, remove the #1521 Lever Rod and force the **forward end** of the Track outward by sliding on the Track Rods.

Stop sliding when the Track’s Inner Chain is centered **between** the Inner & Outer Sprockets of the Front Idler...see drawing below. **NOTE:** For the sake of clarity the Track Rods are not shown in the drawing below.

Now in a similar manner, using the #1521 Lever Rod on the Rear Drive, rotate the Track

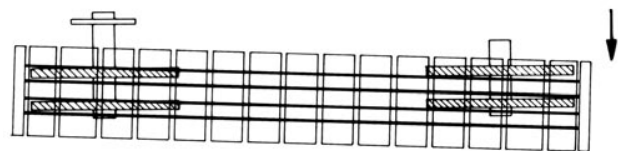

rearward and remove all the previously installed #1229 Track Rods making sure that the Track’s Inner Chain remains between the Inner & Outer Sprockets on the Front Idler.

With all the #1229 Track Rods removed from the Front Idler, continue rotating the Track **rearward** and in a similar manner as above, install the Track Rods between alternate mating teeth of the Rear Drive's Inner & Outer Sprockets...keep Rods evenly centered over their respective Inner & Outer Sprockets.

When the last #1229 Track Rod you have installed has rotated to the 12:00 o'clock position,

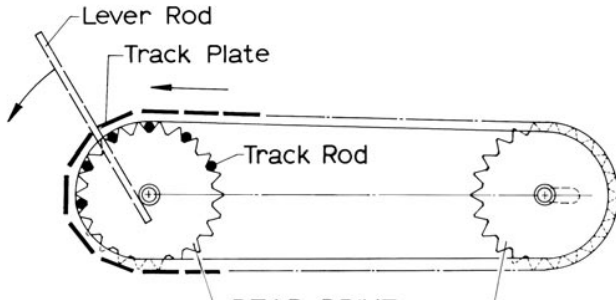

you can force the rearward end of the Track outward and totally off the Inner & Outer Sprockets of the Rear Drive.

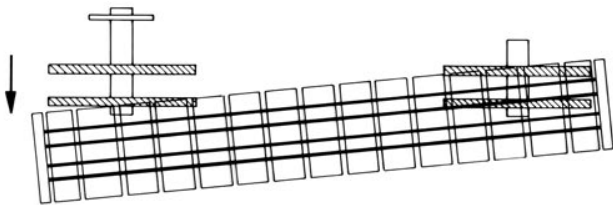

Pulling forward on the Track will allow you to loop the Track off the remaining Sprocket on the Front Idler allowing complete Track removal.

TRACK REPLACEMENT

Slip the **rearward end** of the Track around the Inner & Outer Sprockets of the Rear Drive engaging the Track's Inner Chain between the Inner &

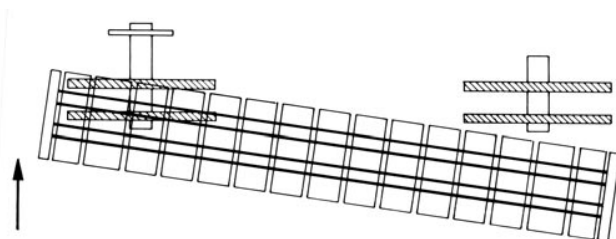

Outer Sprockets of the Rear Drive.

Loop the **forward end** of the Track around Inner & Outer Sprockets of Front Idler...push Track's Inner Chain against Front Idler's Outer Sprocket.

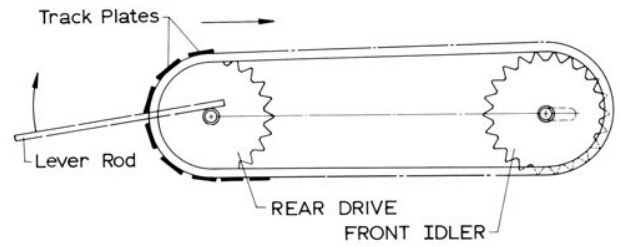

Using a #1521 Lever Rod on the Rear Drive, rotate the Track **forward** while "working" the Track's Inner Chain **up & over** the Front Idler's Outer Sprocket.

NOTE: The above step is probably the most difficult because the end of the Track you are working with is extremely heavy and except for your own lifting efforts is totally unsupported. Here is where your "helper" can be of assistance by using the Lever Rod or suitable crowbar to work the Track's Inner Chain over the teeth of the Outer Sprocket as you support it from above. Again, supporting the "lower strand" of the Track will give you additional slack to work with!

Stop when the Track's Inner Chain is located

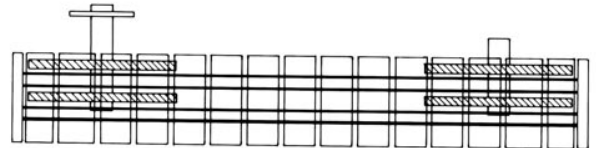

between the Inner & Outer Sprockets of the Front Idler and Rear Drive.

Relocate the Lever Rod and begin rotating the Track rearward. As the Track rotates rearward, insert Track Rods between the alternate mating

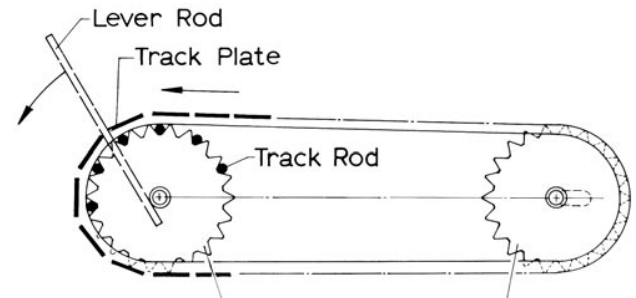

teeth of the Rear Drive's Inner & Outer Sprockets...keep Rods centered over their respective Inner & Outer Sprockets.

When the last Track Rod you inserted rotates to the 12:00 o'clock position, remove the Lever Rod and force the Track **inward** until the Track's

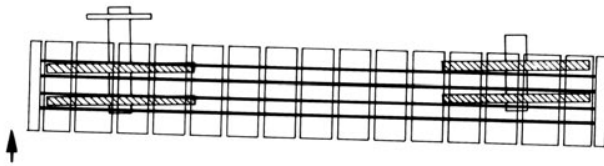

Reinsert Lever Rod and rotate the Track **forward**. Hold the above alignment and allow the Sprocket's teeth to enter their respective Track's Inner & Outer Chain. While rotating Track, remove all Track Rods as they drop free.

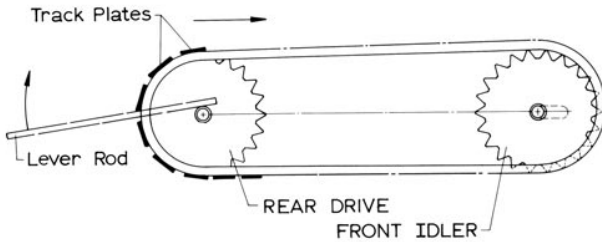

Continue rotating Track **forward** while inserting Track Rods into the alternate mating teeth of the Front Idler's Inner & Outer Sprockets...keep Rods centered over their respective Inner & Outer Sprockets.

When the last Track Rod inserted rotates to the 12:00 o'clock position, remove the Lever Rod and force the Track **inward** until the Track's Inner & Outer Chains align with their mating Inner & Outer Sprockets on the Front Idler.

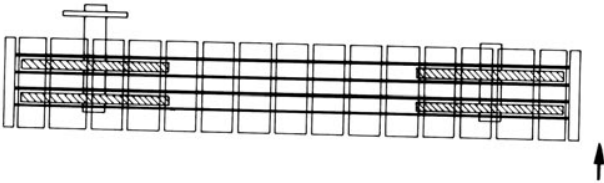

Rotate the Track **rearward** while holding the above alignment and allow the Sprocket's teeth to engage their respective Inner & Outer Track Chains. Remove all the Track Rods as they drop free; save them for next time.

Replace the #234 Spring (black) by slipping it over the end of its respective #1030 Rod (on outside of Track) and over its #262 Tube, which should still be in place on #1030 Rod. Secure Spring with a #235 Washer followed by a 1/2" Nut (fine thread).

In a similar manner replace the #233 Spring (yellow) over its respective #1030 Rod & #262 Tube (on inside of Track)...secure with #235 Washer followed by 1/2" Nut (fine thread).

By rotating each #1030 Rod **clockwise**, draw

the 1/2" Nut & #235 Washer (on each Rod's end) against its respective #233 or #234 spring. A set of pneumatic air tools will greatly aid in this process! The original factory measurement of the (black, outside) #234 Spring is 4.5 inches. The inside spring #233, will **NOT** be the same measurement. (Don't include the washers with this measurement). **Make sure the #215 Front Axle is square with the Lower Frame. Pick a point on both sides of the Lower Frame and measure to the closest point of the Front Axle. If the Front Axle is not square with the Tracks, they will work themselves off in either direction.**

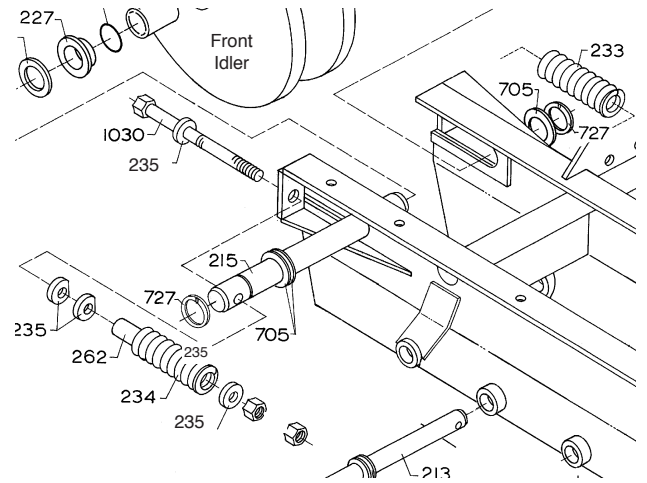

NOTE: If you don't follow these instructions, you may strip the threads on the #1030 Rods. Tighten the pair of #233 & #234 Springs 1/4" at a time. Tighten the #234 Spring (black) 1/4", then stop and go to the #233 Spring (yellow) and tighten it 1/4". Work back and forth from #234 Spring to #233 Spring 1/4" at a time. Once you have taken the slack out of the tracks verify that the front axle is square by using the method described above. (*Contact the factory with any questions!*)

At this time, slowly and safely remove all "support" blocking from underneath your Crawler so that the Crawler rests firmly on only its Tracks.

Go on to the next section for instructions on Track Tensioning.

TRACK TENSIONING

Before starting your tensioning procedure, make sure your Track System is relatively clean and free of debris...a high-pressure wash job is an excellent idea.

Drive your MAGNATRAC through a “clean” area to work out debris that may have lodged between Track Sprocket teeth or in the Track’s Chain Links. Park your MAGNATRAC on a firm level surface, shut off engine and dismount.

On the side of the Track you are going to tension, remove its respective #1220 Spring Guard...save Bolts & Nuts for reassembly.

Remove the 1/2” Nut at the extreme end of each #1030 Rod.

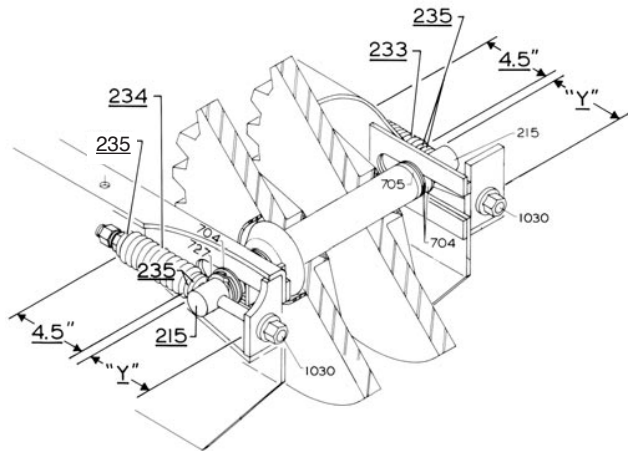

If your tracks have a lot of slack in them or if you have replaced a broken #1030 Rod, follow this procedure:

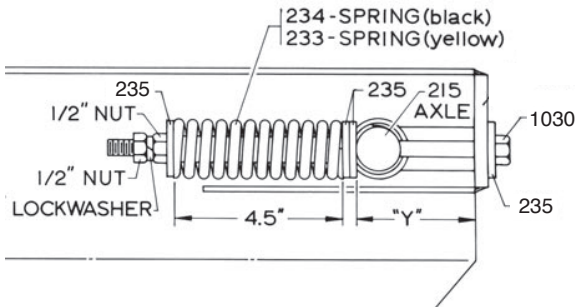

With a wrench or pneumatic tools (recommended); rotate each #1030 Rod so that its respective #235 Washer is drawn **forward** (or released **rearward**) thereby adjusting its respective #234 Spring (black) or #233 Spring (yellow).

Work back and forth tightening each Spring 1/4” at a time. (Follow the guidelines for tightening the springs in the Track Replacement Section above).

You want to take out the slack in the tracks, don’t over tighten. Make sure the front axle is square and that you are satisfied with the track tension.

At this time remount and safely restart your Crawler. Drive it approximately 25 feet forward and then go in reverse back to your starting point. Shut off the engine and dismount. Check the

overall length of your #233 & #234 Springs for any changes in length. Readjust if necessary. When satisfied, secure each 1/2” Nut (on end of each #1030 Rod) with another 1/2” Nut...fully tighten.

NOTE: To achieve ideal Track alignment, the “Y” distance (the distance from the rear face of the #215 Front Axle forward to the **rear face** of the frame block) should be equal on each end of the #215 Axle you are adjusting.

To accomplish this, loosen the 1/2” Nut on the end of the #1030 Rod holding the #233 Spring (yellow) and “fine tune” the overall length of the #233 Spring using the procedure described above.

When equal “Y” distances have been achieved, replace and tighten the 1/2” Nut on extreme end of #1030 Rod holding the #233 Spring (yellow).

Using original Spin Lock Bolts and Nuts, replace the #1220 Spring Guard removed above...tighten.

NOTE: To get the most life out of your tracks; you can take two track pads out of your tracks after a period of time where they have stretched to the max. Make sure you have tightened your springs as much as possible and that you have no more room in the slot where the #215 front axle sits. To do this, follow the steps in the Track Removal section of this manual and then put each track on end and grind down each pin head till it sits flush with the outer chain link. Using a vise-grip; secure it into a 1/4 punch or long 1/4 inch bolt and lock vise-grip into place. Use a lubricant, like WD40 to ease the pin out. With a hammer, carefully pound the pin through without hitting your hand or damaging the mating outer link and secure with new pins and cotter pins purchased from the factory. **NOTE: You need to match up an inner track link and an outer track link to make a connection to each other.**

Contact the factory with any questions!

TRACK SPROCKET & TRACK IDLER LUBRICATION

Lubrication of the center Idlers is accomplished by greasing through #2061 grease Fittings. The grease Fittings are “submerged mounted” in the outside ends of all eight of the #213 Idler Axles and the two #214 Rear Axles and

#213 Idler Axles and the two #214 Rear Axles and are lubricated from the sides of the Crawler (See Part Photos MH-32).

The Front Idler Sprocket assemblies have #1523 45 degree grease fittings mounted in their Tubes and are lubricated from the front of the track on the inside part of the tube by the yellow spring. The tracks may have to be rotated to find this 45 degree grease fitting. (See Photo MH-37). It is a good idea to clean out the track system of debris each time you lubricate to spot problems before they become expensive maintenance items.

TRACK IDLER MAINTENANCE

NOTE: The #1218 Track Idlers are made of a slightly softer steel than the Track Chain. This has been done to allow the inevitable wear to be concentrated on the less expensive Idlers thereby protecting and greatly extending the life of the much more expensive Track Chain.

The Track Idlers, after a few hours of running time, will have their inside walls **hard-peened** into a configuration that will precisely mate with the contour of the Track Chain they are guiding. This **peening** process creates not only a mating inside surface on each Idler, but also rolls a wider extended edge around each Idler's circumference. In addition, the Idler surfaces are "work hardened" by being **peened** against the harder Track Chain.

The #1218 Track idlers are equipped with two internal oilite bushings. As these bushings wear the idler will become loose on the axle. These bushings can be replaced to extend the life of the idler.

The 4.5" diameter flanges of the #1218 idlers will continue to wear over time. Individual idlers should be replaced when track chains begin wearing into the tube connecting the flanges.

TRACK SHOES

Your MAGNATRAC comes from the factory without any Track Shoes being installed unless you had them factory installed. You can safely run your Crawler without Track Shoes, but under average soil conditions you will be able to attain only about 80% of your MAGNATRAC's traction ability. For rocky conditions we advise to have some type

of a bolt on shoe for strength.

To gain more traction, you can add the TSO40 Grouser Shoes or the TSO45P Non-Marking Shoes. Under average soil conditions, the addition of Non-Marking Shoes to your Track will increase traction to approximately 80% of your MAGNATRAC's traction ability. Adding Grouser Shoes will give you the greatest traction ability your MAGNATRAC can deliver.

GROUSER SHOE INSTALLATION

Align 3/8" square holes in each Grouser Shoe with mating 3/8" square holes in *top outside face* of each Track Plate and secure with 3/8 x 3/4" Carriage Bolts and 3/8" Flange Lock Nuts.

Using pneumatic tools to do this installation will greatly speed up the process. In addition, securely blocking the tractor on its round steel tubing that goes through the undercarriage is a good place to block the tractor. Once you have the tractor up and well blocked, you can run the tracks around to help with the installation of the shoes. If you choose not to block the tractor and do the installation with the tractor firmly on the ground; you will have to run the tractor forward every couple of feet to do the installation.

NON-MARKING SHOE INSTALLATION

The method for blocking the tractor is the same. See the instructions for optional TSO45P Non-Marking Shoes.

8- TROUBLESHOOTING

Below are tips and guidelines for troubleshooting some problems or concerns, which may occur during the life of your equipment. Should these guidelines not solve a problem please contact the factory for further instruction.

Engine won't crank.

- There are **3 electrical safety switches** on every crawler (**seat safety switch, brake pedal safety switch and Auxiliary 1,2 safety switch**). If the safety switches are not in contact; the switches will prevent the tractor from cranking.
- With a continuity tester verify that the Brake safety switch is operating properly.
- Check to see if the solenoid is working. When you turn the key from run to off position you should hear a clicking sound. Have another person listen while an operator tries to start the unit.
- Verify that the wiring is in good condition. Check all wiring connectors and replace the Ignition Switch and wiring if needed.

Engine cranks but won't start or starts and stops running right away.

- Verify there is adequate fuel & that the fuel filter is in good condition. Take off the fuel filter and fuel line by the tank. Check to make sure the fuel line and/or tank is not clogged with any debris. Check hoses leading to the fuel pump and to the carburetor. Also, check that the fuel shutoff is in the open position.
- Verify seat safety switch is being engaged and operating properly. The connection may be loose.
- Replace with new fuel.
- Carburetor may be clogged and or new fuel pump may be needed.

Engine dies when not in the seat.

- This is a normal operating characteristic to safeguard against accidental engagement of the tractor and/or attachments while not properly located in the operator's seat.
- If the engine dies continuously, check the wire connections and verify wires are not frayed or damaged.

Do Not Bypass this safety feature.

Tractor drive and/or attachments behave erratically.

- Verify hydraulic fluid level is within the required operating range. Low fluid levels can result in air intake to the hydraulic system, which can result erratic operating characteristics.
- Verify the large suction lines are properly secured by their hose clamps. Loose suction lines can result in air intake and erratic operation.

Track tensioning adjustment has reached its limit, but tracks are still loose.

- It is possible to remove links from the track chain to shorten the track loop. See the Service section of this manual. Contact factory for details.
- Tracks need to be replaced.

One cylinder function of an attachment is not responding.

- A non-functioning cylinder can result from either a problem with the cylinder or the valve section operating the cylinder. To test, take the two hoses of the non-functioning cylinder and switch their connection at the operating valve with those of the adjacent valve section.
 - If the non-functioning cylinder continues to not operate the cylinder is faulty.
 - Should the cylinder now work, but the cylinder of the control that was switched stops working problem lies in the valve section.

Tractor has little power.

- Verify engine throttle is adequate; check the throttle connections.
- Verify hydraulic fluid level is adequate. It should be just showing at the bottom of the EOL™ Easy Oil Level window.
- Verify there are not external loads draining engine power (e.g. the PTO is operating although not needed).
- Move Auxillary 1 & 2 handles to the neutral position.

Tracks are making a popping sound.

- It is not uncommon in the initial operating hours for the track system to make popping noises as the initial wear in occurs.
- Debris (rocks, branches, etc...) drawn into the track system will most likely be crushed, broken, or shattered resulting in popping noises. Check for stuck items in the track chain like rocks or other debris.
- Verify the track tension on the front idler sprockets is evenly adjusted on the inside and outside of the track. Unequal tensioning can result in the front idler sprocket running at an angle not parallel to the track line. (See the Service section of this manual). This results in tracks riding up the teeth of the sprocket and snapping back down to produce a popping noise.
- Check track sprockets for heavily worn teeth that would allow the sprocket to jump inside the tracks.
- Verify that the tracks are tensioned. Excessively loose tracks can result in the drive sprocket jumping inside the tracks.

One track drive responds only intermittently.

- Inspect sprockets on the #4005 Disk Drive and #4006 Primary Drive for broken teeth. This can result from inadequate tensioning of the #60 and/or #80 drive chains, which allows the chains to ride up and break the tips of the drive train sprocket teeth. See the Service section of the manual or call the factory for repair instructions.

Tractor does not drive perfectly straight.

- Due to normal inefficiencies in the hydraulic system each track must be individually controlled to achieve a straight travel path. Operating both drive handles equal distance will naturally result in a “slightly” curved travel path. If this condition is extreme, contact the factory for possible problems

Tracks came off.

- Do NOT proceed operating the MAGNA TRAC. Lower all attachments and apply the parking brake. Inspect the area for causes. See the Service section of this manual for possible problems and fixes. Call the factory with questions.

MAGNATRAC is stuck.

- Use the down pressure of the attachments to loosen the tracks. Call the factory with any questions.
- To push or tow the MAGNATRAC: Lower all attachments so that they are **just above the ground**. Remove left side panel from the footwell area of the machine. The side panel is the panel that covers the tandem piston pump. As referenced in photo **MH-22 (Left View)**, insert a small screw driver in the hole on the nut and turn the nut cannot be turned anymore. This lets the oil flow back into the tank for “emergency movement” ONLY. Once machine is where you want it for maintenance, more the nuts back to their normal position.

No power to your backhoe or PTO.

- Make sure the auxiliary lever is pulled rearward in the Auxiliary-2 position to provide power to the backhoe or PTO.
- Check the condition of the attachment pump.

No power to any attachments.

- Check condition of the attachment pump.

Hydraulic Oil is overflowing from the hydraulic oil breather.

- Check the hydraulic level in the EOL™ Easy Oil Level System, level when full should show slightly at the bottom of the window. Drain oil out if necessary.
- Check the rating of your 3rd party attachment to make sure it will work with our units. Call the factory with questions.
- Check the hydraulic oil temperature. Don't allow the temperature to get hotter than 180 degrees, damage may result. Allow a cool down if your temperature gauge is over 180 degrees.

Loader or other attachment will not stay in the upward position when handle is pushed.

- Check the relief valve fitting on the attachment valve. Call the factory for help.

9- SAFETY & WORK PROCEDURES for MAGNATRACS



The following material is designed to familiarize you with the basic characteristics of a MAGNATRAC (tracked Vehicle). Its purpose is to teach you how a MAGNATRAC responds in comparison to the more familiar wheeled tractors. In addition, it outlines safe and efficient work procedures for a compact crawler tractor equipped with standard attachments (loaders, backhoes, blades, etc.)

Each MAGNATRAC operator encounters dramatically different working conditions than another. For this reason the following drawings and descriptions are general in nature. They illustrate general points rather than details which may apply to only one operator's working conditions. You are encouraged to contact the factory at anytime for help or advice for any job you have in mind.

A tracked Vehicle, by its very nature, requires the use of operating techniques and procedures that are unfamiliar to most people used to driving wheeled vehicles.

This means that a person intending to operate a Tracked Vehicle must allow himself ample opportunity to familiarize himself with the controls and characteristics of the machine.

It is the purpose of this booklet to inform and instruct prospective Track Vehicle operators in an effort to help them use it safely.



SAFETY WARNING: NO PERSON SHOULD ATTEMPT TO OPERATE A TRACKED VEHICLE BEFORE READING THIS BOOKLET THOROUGHLY. IF ANY PORTION OF THIS BOOKLET IS NOT CLEARLY UNDERSTOOD, WRITE TO US AT THE ADDRESS ON THE FRONT COVER.

TRACKED VEHICLE CHARACTERISTICS

Tracked vehicles possess certain inherent features not found on standard four-wheel vehicles. For instance, a standard vehicle will hit bottom when the wheels on either end are driven over a drop-off. In most cases this will stop vehicle motion and give immediate warning.

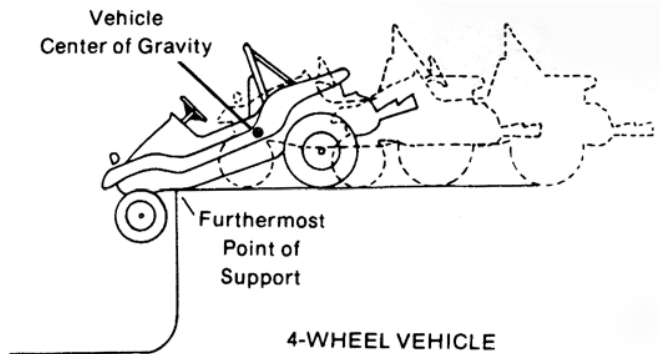

A tracked Vehicle, however will continue on without any warning until its center of gravity passes across an imaginary line drawn straight up from the furthest point of support with ground. It will drop **SUDDENLY**. (See illustration upper right). **THIS WILL HAPPEN EVEN AT THE**

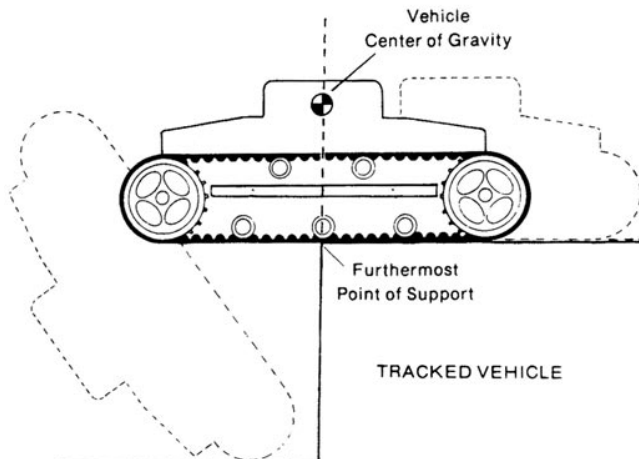

VERY SLOWEST SPEEDS.



SAFETY WARNING: ANYTIME A PORTION OF THE TRACK IS NOT IN CONTACT WITH THE GROUND, STABILITY IS REDUCED. NEVER ATTEMPT TO 'JUMP' A TRACKED VEHICLE OVER DROP-OFFS, HILL CRESTS, OR OTHER OBSTACLES. THIS CAN BE EXTREMELY HAZARDOUS.

A Tracked Vehicle can climb or descend steep slopes, so

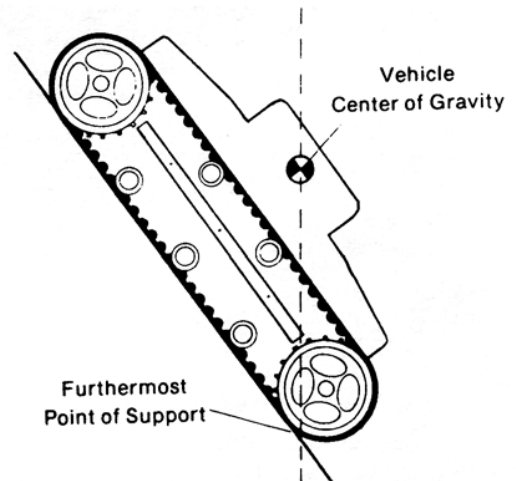

steep in fact that the vehicle can tip over forward or backward, before it loses traction.

Tipover occurs when the Vehicle's center of gravity passes across an imaginary line drawn straight up from the furthest point of support with ground.

When the vehicle's center of gravity passes this point, the vehicle will tip over **SUDDENLY**.

TRACKED VEHICLE OPERATION

A Tracked Vehicle, by its very nature, is a vehicle requiring a great degree of care and judgment during operation. It should be kept in mind that while your Tracked Vehicle is designed to operate in rough terrain, this same fact allows for the possibility of a hazardous condition developing at any time. Safe operation of your Tracked Vehicle must be based on the understanding of the vehicle's limitations, thorough knowledge of the controls and their functions, and the operator's good judgment and experience.



SAFETY WARNING: WHERE THE OPERATOR IS NOT CERTAIN OF THE VEHICLE'S ABILITY TO TRAVERSE AN OBSTACLE OR TERRAIN SITUATION, OR, IS NOT CERTAIN OF HIS OWN ABILITY TO SAFELY OPERATE THE VEHICLE, AN ALTERNATE ROUTE MUST BE TAKEN.

OPERATION ON SLOPES

Tracked Vehicle operation on slopes presents an obvious opportunity for the vehicle to tip over. This type of operation demands constant attention to changes in terrain and the ability to anticipate and avoid possible hazards.

This ability can only be developed through careful study of the points noted in this section and a slow, planned effort on the operator's part to become proficient.

The most effective guard against hazards while operating on slopes, especially during downhill operation is to keep vehicle speed very slow.



SAFETY WARNING: WHEN OPERATING ON SLOPES VEHICLE SPEED SHOULD BE KEPT VERY SLOW AND THE OPERATOR SHOULD BE EXTREMELY ALERT FOR CHANGES IN TERRAIN.

Vehicle stability on a hill, for example, is determined not only by the general slope of the hill but also by terrain conditions (rocks, ditches, logs, drop-offs, etc.) and by the nature of the hill surface (gravel, sand, grass, snow, rock, etc.), the payload which the vehicle is carrying, the manner in which the payload is distributed within the vehicle, attachments and accessories which have been added to the vehicle, and so forth.

Similarly, driving technique and its effect on vehicle stability enters into any determination of what constitutes a safe slope. Excessive speed, sudden braking, choice of path - all can be critical.

UPHILL OPERATION

The following illustrations depict some situations in which a Tracked Vehicle can be expected to tip over.

Variations in speed, loading, terrain and vehicle condition must all be analyzed to determine whether or not a specific obstacle can be traversed. If in doubt, do not attempt.

SAFETY WARNING: ON STEEPER SLOPES SMALLER OBSTACLES WILL CAUSE A TRACKED VEHICLE TO TIP OVER.

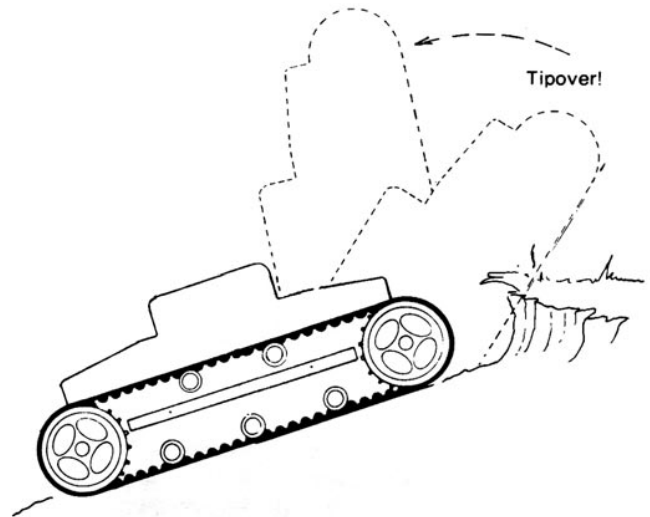

It is common to see a situation where a natural erosion has caused the very top of a bank or hill to rise sharply. Always check for this condition before attempting to climb any such type of terrain. A Tracked Vehicle could climb up to a point at which it falls over backward.

It is also very important to check for this terrain condition before going down over the edge of a bank or dropoff.

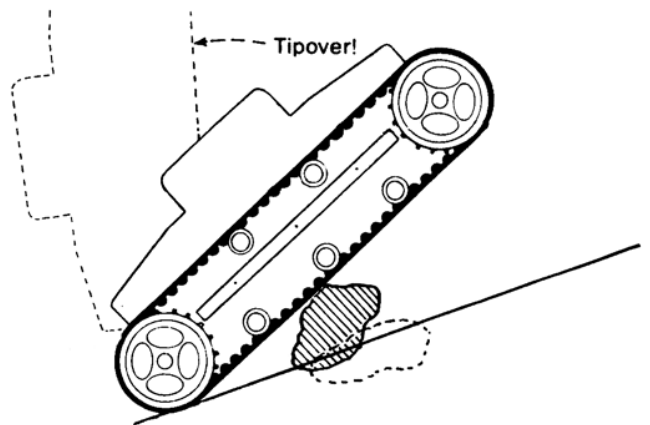

The same situation can occur where an embedded object is pulled from the ground. The vehicle track may 'grab' a rock or log. As the object emerges from the ground, rolling under the track, the vehicle could climb to the point at which it falls over backward.

DOWNHILL OPERATION

SUDDEN STOPS

If a Tracked Vehicle is driven down a slope and the tracks are stopped suddenly, the vehicle's exceptional traction may cause it to tip over forward.



SAFETY WARNING: IF VEHICLE MOTION IS ABRUPTLY DECREASED OR STOPPED, A TRACKED VEHICLE CAN TIP OVER FORWARD. THIS POSSIBILITY BECOMES GREATER AS THE VEHICLE SPEED AND/OR DOWN SLOPE INCREASES.

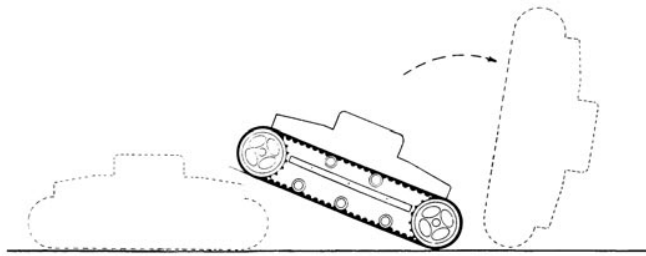

CROSSING OVER AN OBJECT

This illustration is drawn to depict an obstacle situation in which a Tracked Vehicle can be expected to tip over. Variations likely to occur in natural terrain, the approach to the obstacle, operator skill and loading of a Tracked Vehicle may reduce the size of obstacle or steepness of the slope required, which could cause tipover.

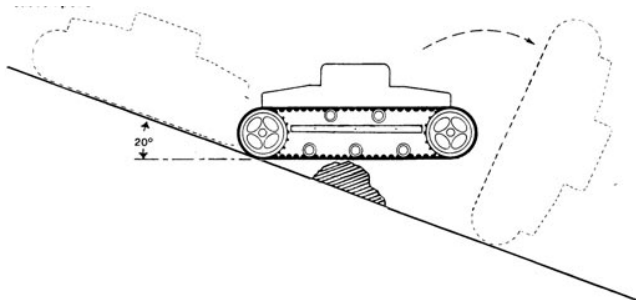

SAFETY WARNING: IF THE VEHICLE'S CENTER OF GRAVITY PASSES THE POINT OF SUPPORT, A TRACKED VEHICLE WILL BEGIN TO TIP. UNLESS THE TERRAIN ON THE DOWNSIDE OF THE OBJECT PROVIDES A NEW POINT OF SUPPORT, FAR ENOUGH AHEAD OF THE VEHICLE CENTER OF GRAVITY TO NEGATE THE EFFECT OF INERTIA, A TRACKED VEHICLE WILL TIP OVER FORWARD.



SAFETY WARNING: ON STEEPER SLOPES, SMALLER OBSTACLES WILL CAUSE A TRACKED VEHICLE TO TIP OVER.



SAFETY WARNING: OBSTACLES, SOME OF WHICH MIGHT BE DRIVEN OVER SAFELY WHILE ON LEVEL TERRAIN, CAN CAUSE A HAZARD WHILE OPERATING ON SLOPES.

DROPOFFS

This illustration is drawn to depict a dropoff situation in which a Tracked Vehicle can be expected to flip. Variations occurring in natural terrain, the approach to the obstacle, operator skill, and loading of a Tracked Vehicle may reduce the size of the dropoff or the steepness of the slope, which could cause tipover.

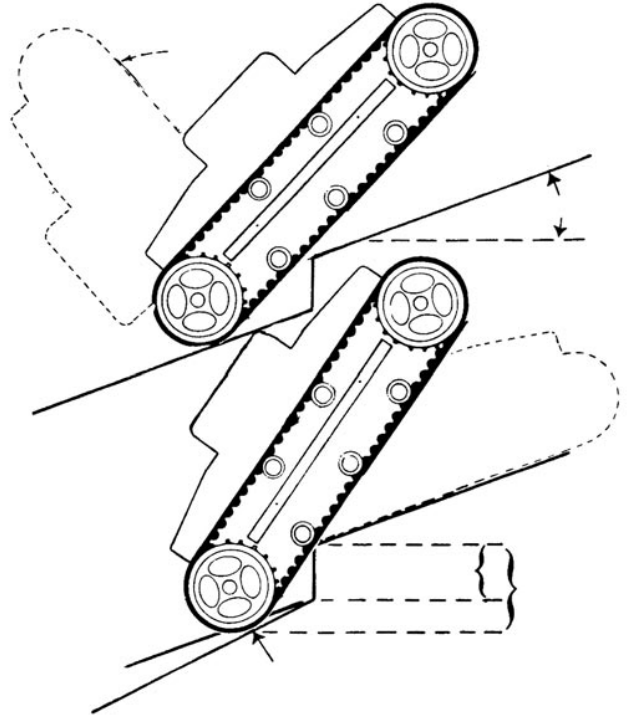

SAFETY WARNING: A TRACKED VEHICLE MUST BE OPERATED WITH GREAT CARE AT ALL TIMES AND ON ANY SLOPE. SLOPES STEEPER THAN 20° SHOULD BE REGARDED AS ULTRA-HAZARDOUS AND APPROACHED WITH EXTREME CAUTION. EVEN ON SLOPES OF LESS THAN 20°, A TRACKED VEHICLE CAN BE TIPPED OVER BY A SUDDEN STOP, EXCESSIVE SPEED, UNEVEN TERRAIN, OR OTHER SPECIAL CONDITIONS OR COMBINATIONS OF SUCH CONDITIONS.

An important variable in determining if a give obstacle will cause a Tracked Vehicle to tip over is the vertical distance between the last point of contact and the new point of support. Note that the new point of support can be on level ground, a downhill slope, or a steeper downhill slope. The apparent size of the obstacle or dropoff is not the same as the drop it causes. Among the many other

variables are the steepness of the slopes, size of the obstacle causing the drop, the shape of the last point of support, the load on the Tracked Vehicle, initial speed, tightness of the track, traction, symmetry of the obstacle to the Tracked Vehicle and operator skill and judgment.

SIDEHILL OPERATION

The illustrations show how driving over an obstacle with the uphill track or into a hole with the downhill track will cause the vehicle to tip over sideways.

A slippery surface, like snow, ice, frozen sand, and loose gravel can also be dangerous. It is possible to slide into a tree or rock or to slide off the edge of a cliff.



SAFETY WARNING: REGARD ALL OPERATIONS ON SLOPING TERRAIN AS HAZARDOUS.

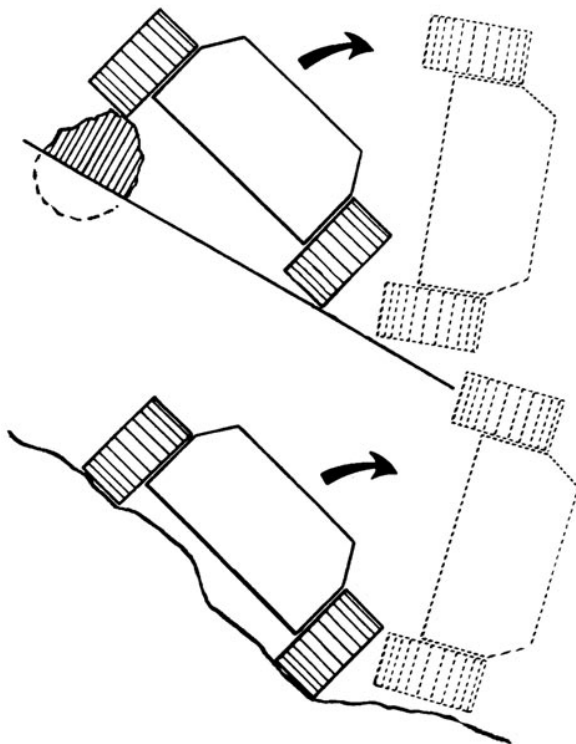

PARKING THE VEHICLE

When a Tracked Vehicle is parked on a sufficient slope, failure to engage the parking brake, or failure of the parking brake to function properly-can result in the vehicle rolling down the slope, out of control.

OPERATING SAFETY PRECAUTIONS

1. Keep hands and feet inside vehicle.
2. Never attempt to operate the vehicle from anywhere other than the driver's seat.
3. Avoid unnecessary quick stops.
4. Avoid quick turns.
5. Shut off engine and engage parking brake when leaving vehicle.
6. Park sideways on slopes.

LOADER OPERATION

Suggested operating techniques for loader operation are outlined in this section. Practice the lever movements as you operate the loader through the various jobs described.

Filling the Bucket

Set the bucket to the level position. Approach, then enter the pile.

Ease the control levers to lift and roll back the bucket.

Lift and roll back of the bucket will increase efficiency because a level bucket throughout the lifting cycle resists bucket lift and increases breakaway effort.

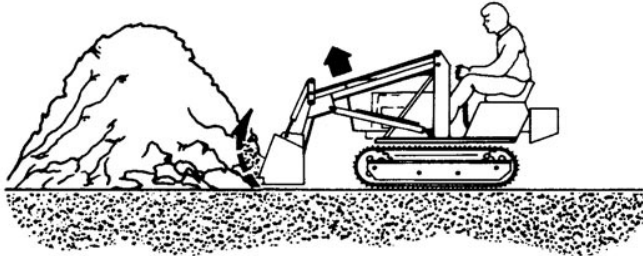

NOTE: Do not be concerned if the bucket is not completely filled during each pass. Maximum productivity is determined by the amount of material loaded in a given period of time. Time is lost if two or more attempts are made to fill the bucket on each pass.

LIFTING THE LOAD

To lift and carry the load, without spillage, fully roll the bucket back after filling and before moving the unit.



NOTE: Do not attempt to lift bucket loads in excess of loader capacity.

PEELING AND SCRAPING

Use down pressure and a slight bucket angle to start long cuts. Make a short angle cut and break out cleanly.

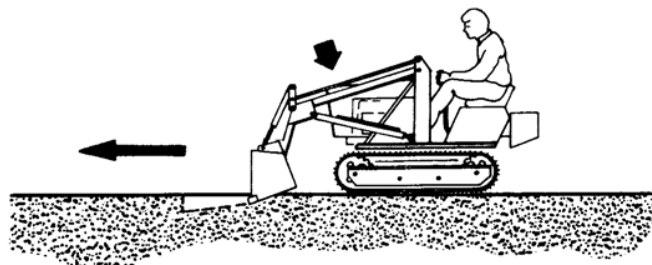

With the bucket level, start a cut at the notch approximately 2 inches (50.8 mm) deep. Hold the depth by feathering the bucket to adjust the cutting lip up or down. When the front of the tracks enter the notch, adjust the lift arms to maintain the proper depth.

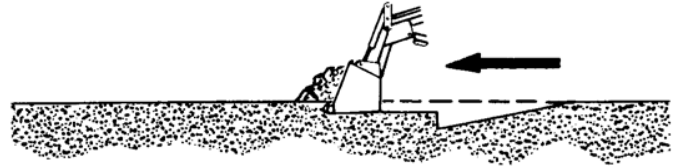

Make additional cuts until the desired depth is reached.

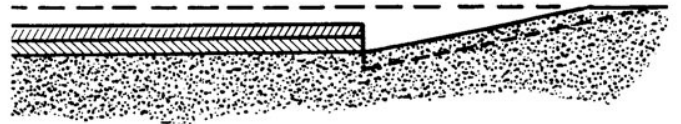

After reaching the desired depth, actuate the loader control lever to compensate for bucket lip action only; do not move the lever for lift cylinder action. Doing this allows you to concentrate on maintaining a precise cut.

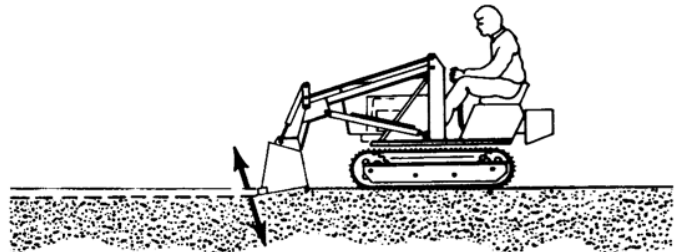

If the lever is moved for lift cylinder action without controlling the bucket angle, the bucket may gouge and leave a series of ruts in the surface.

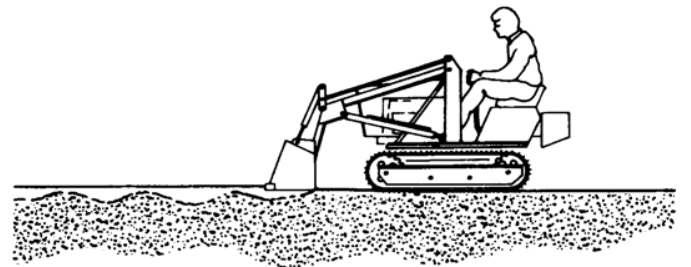

OPERATING WITH FLOAT CONTROL

During hard surface operation, place the control lever in “float” (held by the detent), and keep the bucket level. This will permit the bucket to “float” on the contour of the working surface. If hydraulic down pressure is exerted, the bucket will wear faster than normal.

The ‘float’ position will prevent the mixing of surface material with stockpile material. It will also reduce the chance of surface gouging when removing snow or other material.

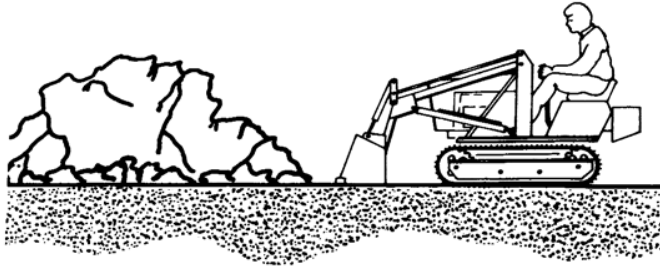

CARRYING THE LOAD

Position the bucket in the full roll back position and the lift arms as low as possible for maximum stability and visibility whether the bucket is loaded or empty.

CAUTION: When operating on a hill or slope, keep the bucket as low as possible. This keeps the bucket center of gravity (C/G) as low as possible, giving maximum stability.

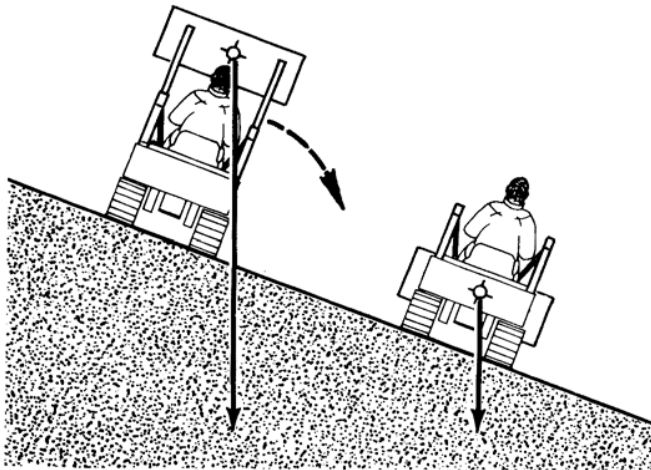

When transporting the load, keep the bucket as low as possible to resist tipping, in case a track drops in a rut.

DUMPING THE BUCKET

Lift the bucket high enough to clear the side of the vehicle. Move unit in as close to the side of the vehicle as possible, then dump the bucket.

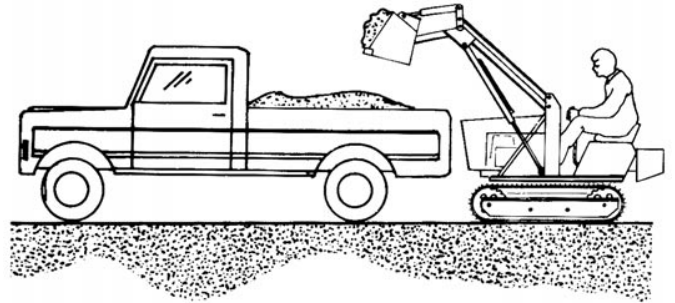

After the bucket is dumped, back away from the vehicle while lowering and leveling the bucket.

BACKFILLING

Efficient backfilling occurs by pushing maximum amounts of soil without losing speed or “stalling.” If a “stall” occurs, downshift or reduce the depth. If the unit is not working at capacity in the gear selected, increase the depth of the cut.

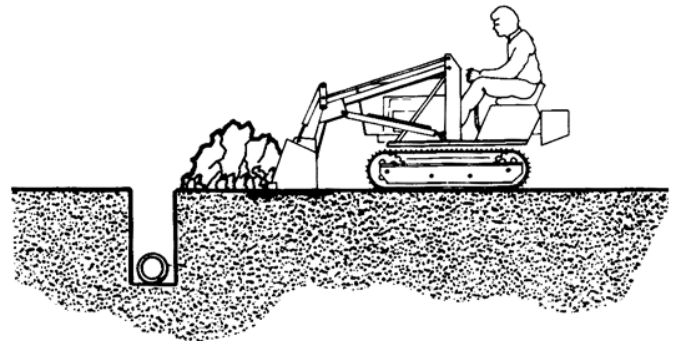

Approach the pile with a level bucket. When adjusting the depth of cut to a load that can be handled without going into a “stall,” actuate the control lever for lift and bucket action simultaneously, or separately as required, to maintain a level bucket.

Leave the soil in the bucket, as dumping on each pass is time consuming. Lift and level the bucket for the next pass while backing from the excavation.

Operate at right angles to the ditch.

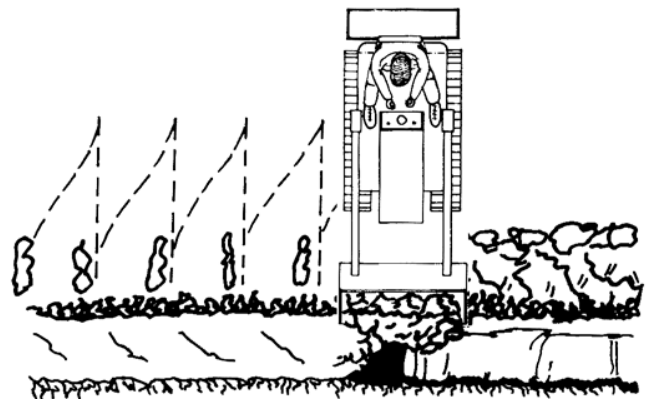

Leave soil that drifts over the side of the bucket for final cleanup.

One lengthwise cleanup pass will usually leave the backfill at an acceptable grade.

When backfilling from a large pile, shovel off the top of the pile, pushing toward the excavation. Drag some soil rearward to form a work ramp of convenient grade.

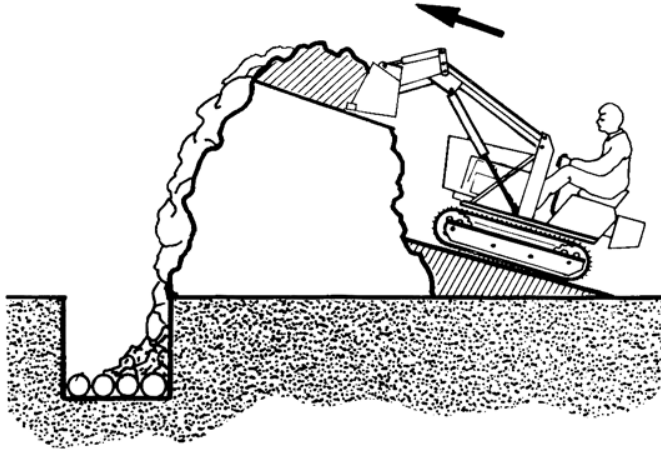

When backfilling on a slope, have the soil piled on the high side for easier backfilling.

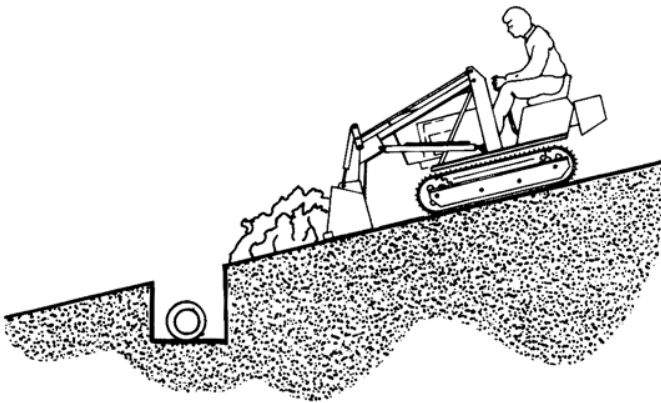

LOADING FROM A STOCKPILE

Initially approach the stockpile with the bucket approximately 6 inches (152.4 mm) off of the ground. Lower the bucket to ground level when the stockpile height has been reduced so the bucket will break out easily.

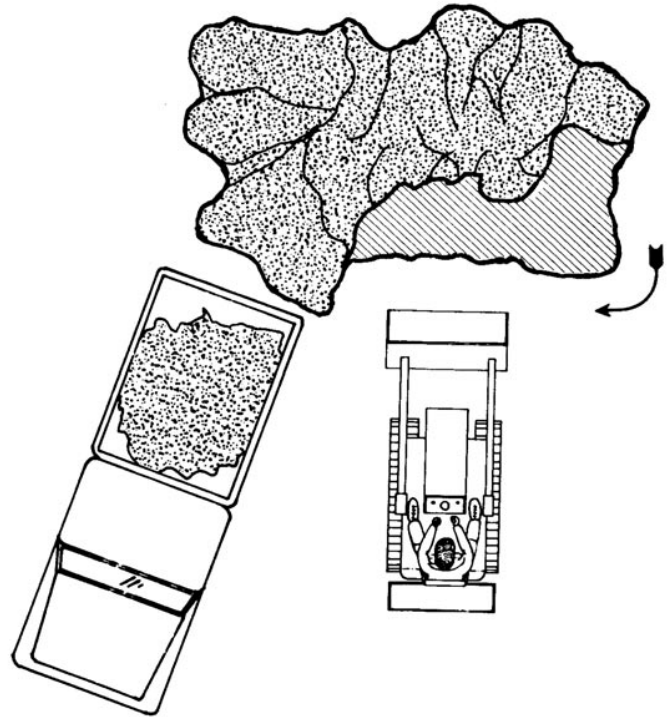

Keep an area clean so the truck or trailer can back in close to the work area. This will minimize travel distance from the pile to the truck. Keep the truck in close and work around the pile.

LOADING FROM A BANK

Select the highest forward gear that provides the most efficient loading operations without going into a "stall."

For faster loading, maintain a 45° turn angle, and work as close to the truck as possible.

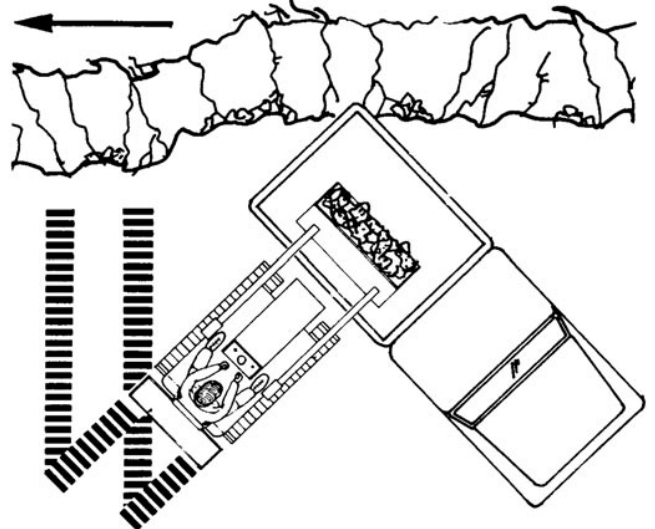

Always keep the truck close to the operation and keep cutting depth half the length of the truck bed.

Backgrade with the bucket occasionally, and approach the bank with the bucket flat. Slight down pressure with the bucket level helps keep the working area smooth. Use the heel or low rear edge of the bucket for back-grading ruts, etc.



If the pile sides are too high and are likely to cave in, use the loader to break them down.

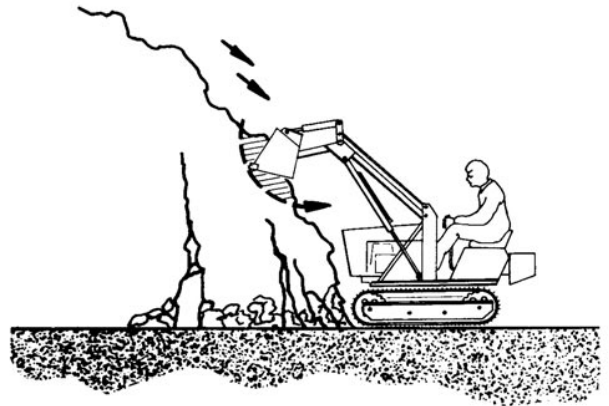

CAUTION: Exercise care when undercutting high banks. Soil slides can be dangerous. Load from the banks as low as possible for maximum efficiency. Remember that loader lift and break-away capacities diminish rapidly as loading height is increased.

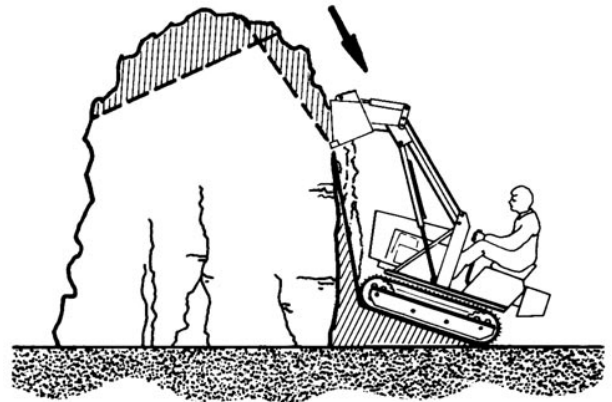
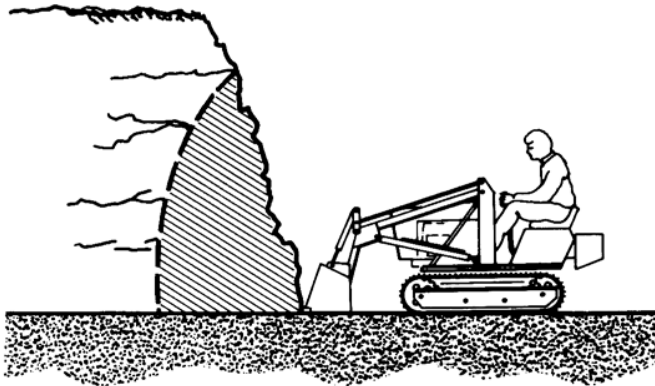

Then, build a ramp by shovel-loading material from the top until a work area is cut through the pile.

If stuck in a ditch...

...dump the bucket and apply down pressure to lift the front of the tracks from the ditch. Actuate the bucket as engine power is applied to move the unit backward.

BREAKING AND SPREADING LARGE PILES.

Side-cutting is a good technique for cutting down a large stockpile.

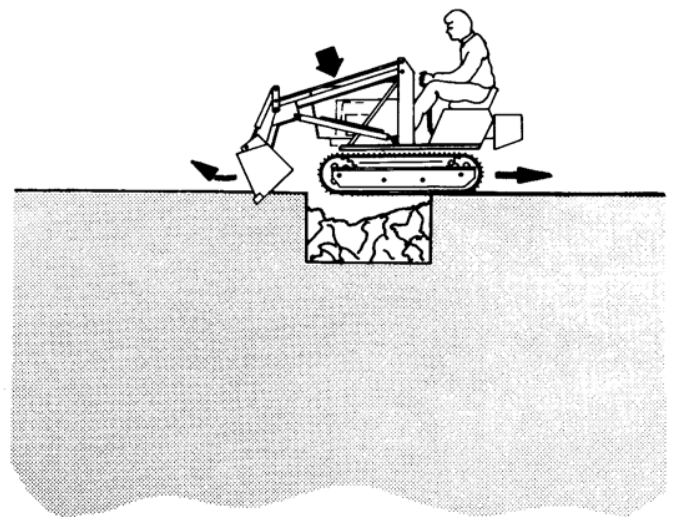
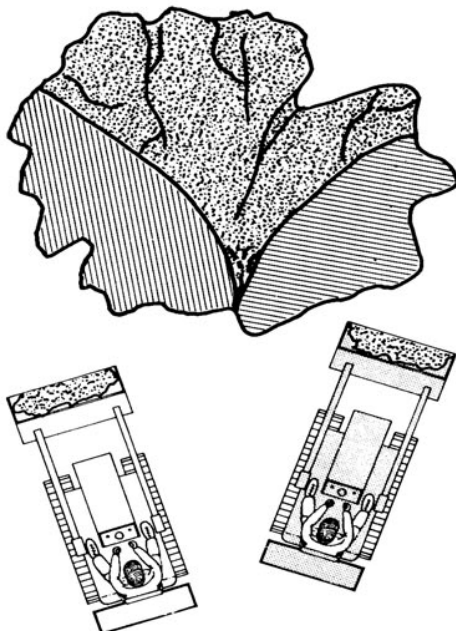

BULLDOZING

DOZER EXCAVATION

When dozing out a pit with a blade or bucket, make cross cuts working from South to North in overlapping swaths. When the bucket or blade fills, lift and push contents over the undug ground which will later be dozed to the opposite side and then out.

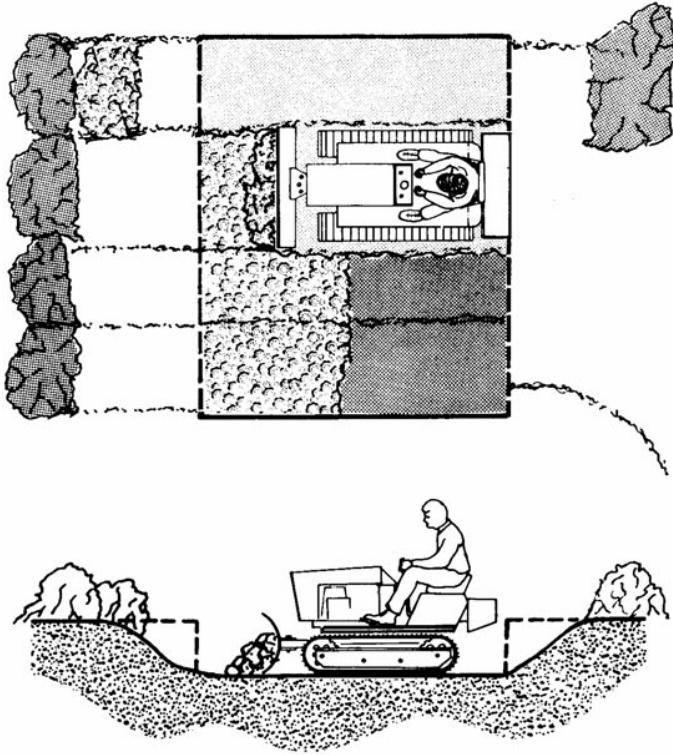

You have to work down from ramps on either side of opening until the desired depth and area are achieved. You should leave one ramp intact so that trucks can deliver foundation materials where they will be used. If soil is excessively hard, loosen it with a ripper or plow. The remaining ramp can be cut out with either a backhoe or by hand.

When regular loading tools are not available it is possible to utilize bulldozers for filling tracks and trailer. Inclined ramps, built of earth, steel or wood, are a means to assist loading economically when level terrain predominates.

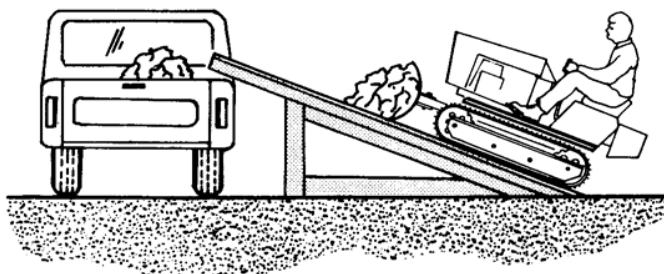

DOZER DITCHING

A dozer and blade can dig wide, shallow ditches effectively as shown in the following illustrations. When the limits for side excavation are reached (A)...

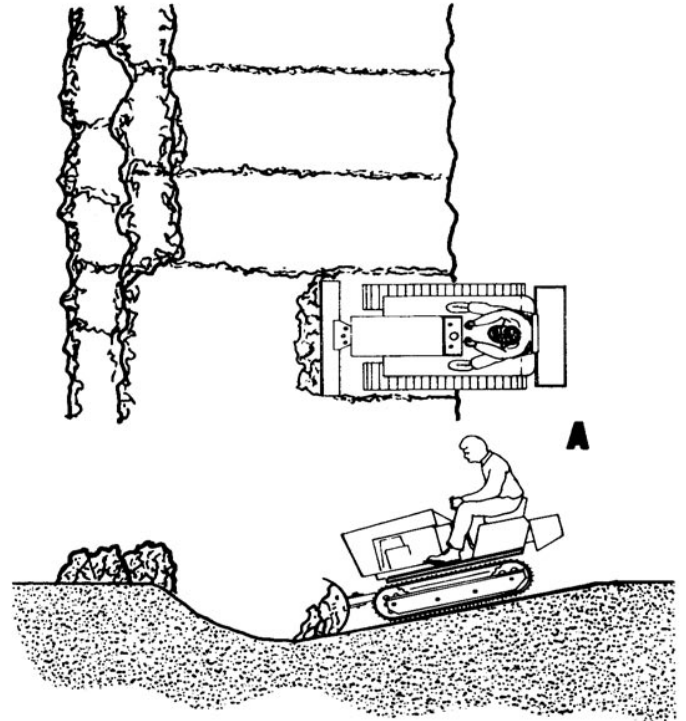

...the unit can work in the trench pushing the material forward into mounds (B), that can then be pushed to the side (C).

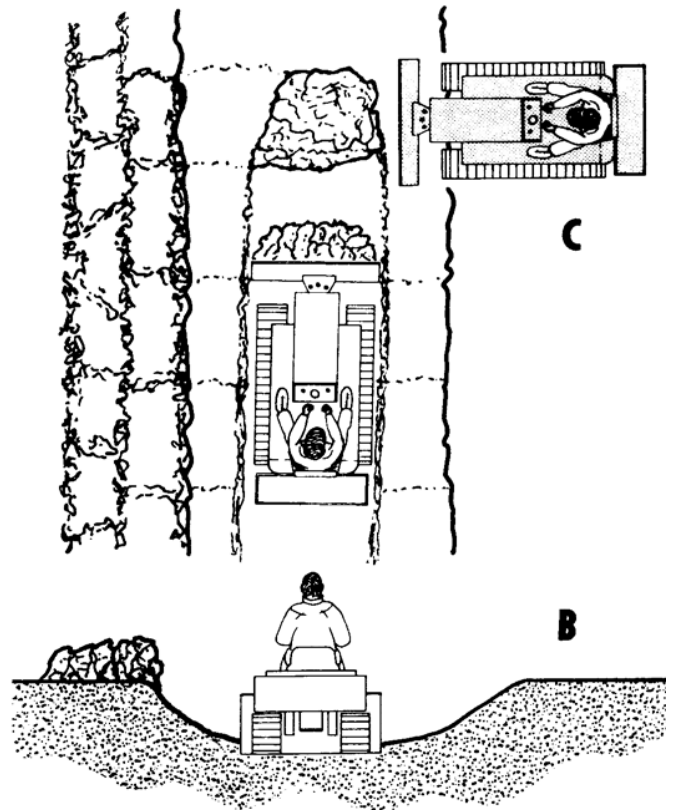

SIDE HILL CUTS

Always start or pioneer all side hill cuts from the top of hills and then work your way down with the cut. It may be necessary to reach the starting point by climbing up a more gradual slope on the opposite side of the hill. Working downhill gives you the advantage of gravity.

1. Working from above

On average terrain start cuts working straight down the hill making short passes to bench out an area (A) large enough so that the tractor can eventually turn and work parallel to the road (B).

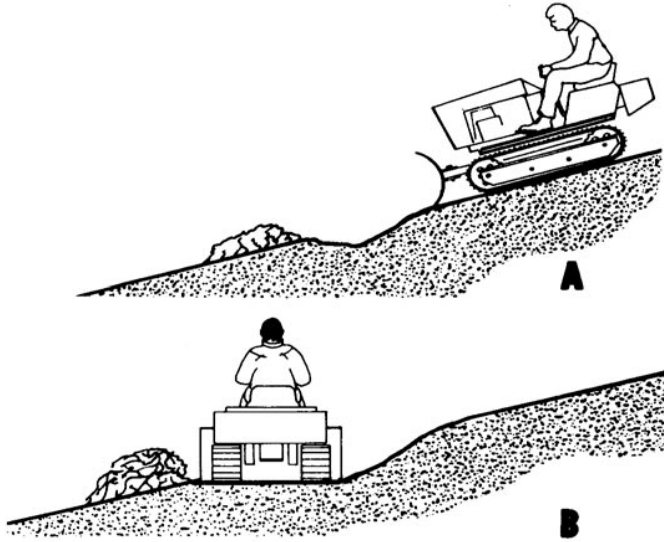

Keep pioneering cuts sloping into the uphill side (C) for maximum earthmoving efficiency.



Make short swinging passes as you work downhill to drift material over the side of the cut (D).

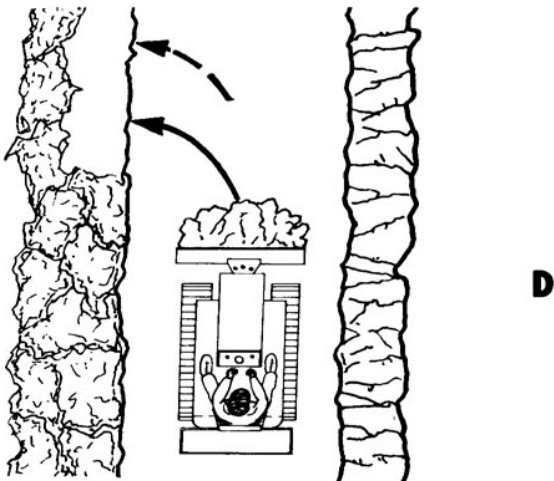

2. Working from Side (only)

A short, wide shelf may also be cut in a hillside, working from the side only as illustrated below.

The first cut (A) is made parallel to the hillside, followed by a second cut (B) in which the tractor's inside track rides in the trough formed by the previous cut. This tilts the tractor to a more level position (depending on depth of trough) and allows succeeding cuts C, & D to be made parallel to the desired finish level.

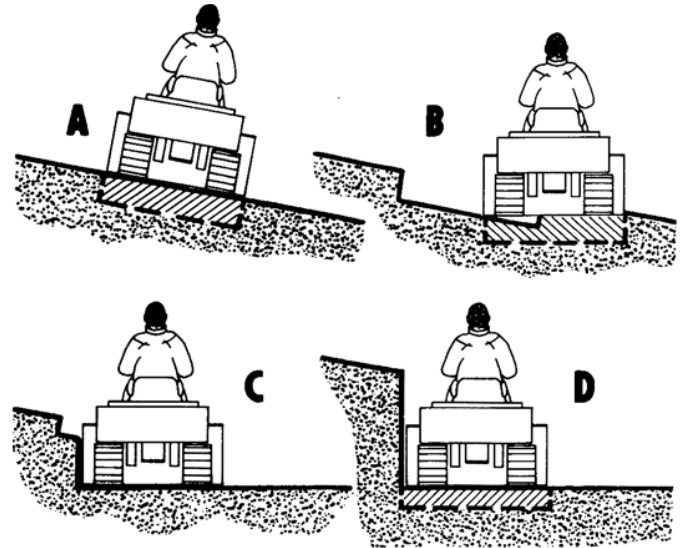

Always keep the fill end high, as the tractor will mire less if it can back up going down grade.

Do not push material further than absolutely necessary in order to stay on firm footing. When backing up, do not raise blade. Raising the blade puts extra weight on the front idlers causing greater track penetration. Let blade float as you back away from the edge of soft fills.

EARTH MOVING

When stripping soil from a road or driveway, either push it forward and angle it to the side (A) or push it forward, then perpendicularly push it to the side (B).

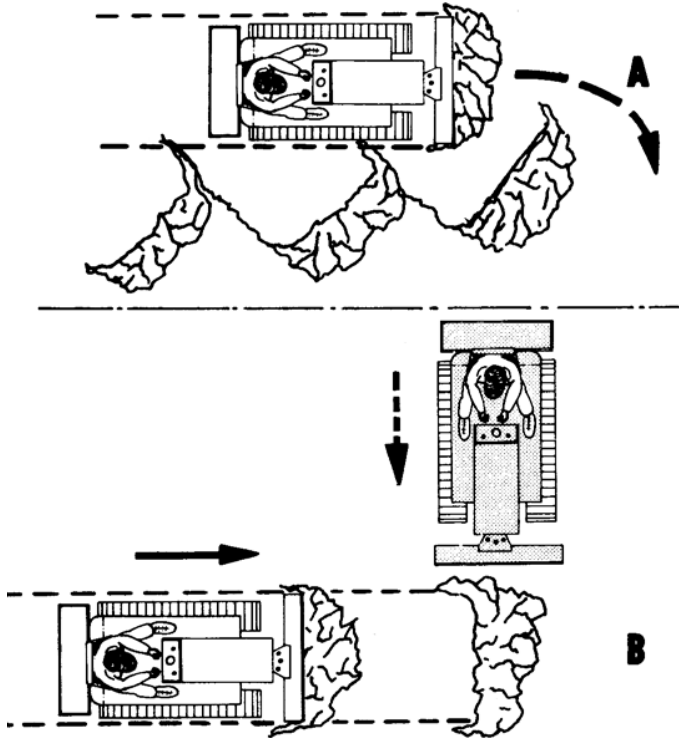

Dirt can be piled by dropping successive loads together, then leveling this material and repeating the process at a higher plane (A). In the alternative, loads can be dumped in the opposite direction, creating the new plateau while pushing loads forward (B).

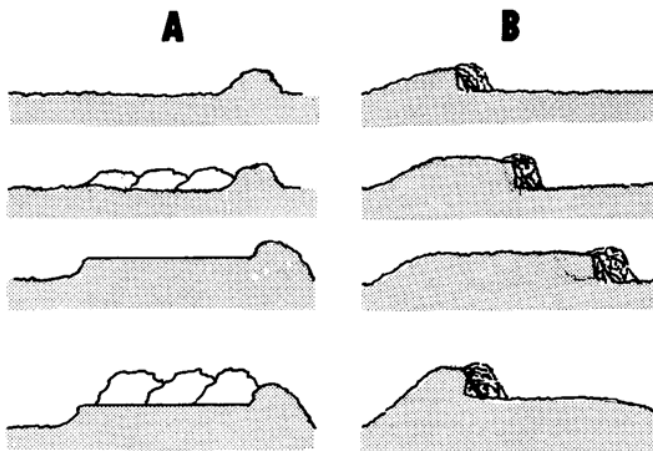

Both methods will work. When working in heavy growth or particularly hard soils, plow or rip the area prior to dozing.

BACKFILLING

Angling blade bulldozers are excellent for backfilling ditches as they can drift material into the trench while maintaining forward motion.

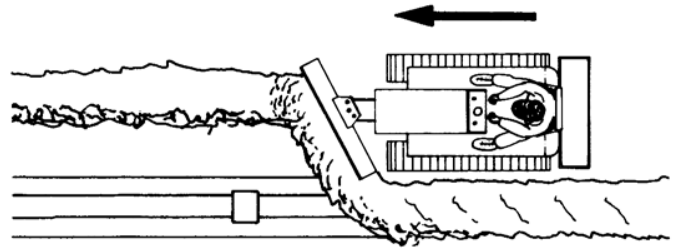

With straight blade dozers, approach at an angle and end up each pass by swinging into the structure or culvert for smooth, fast results.

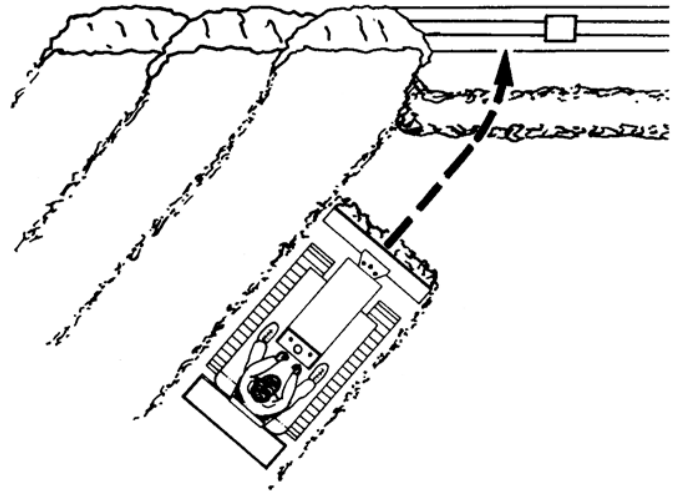

FINISH DOZING

Side slopes can be finished with a dozer by starting at the top and traveling parallel to the right-of-way. Earth from each pass will fall to the lower side of the blade and form a windrow. This material is then picked up on succeeding passes filling up irregularities in terrain. Don't allow blade corner to dig as the slope will steepen beyond job specifications.

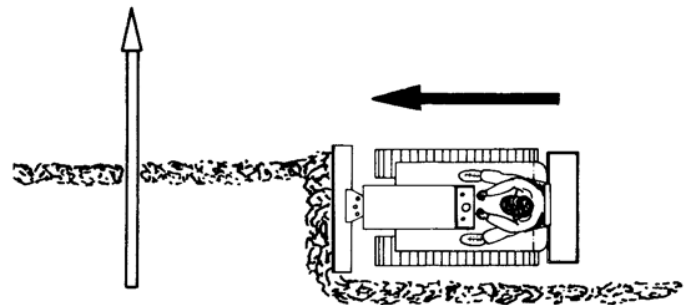

Another method commonly used: Start at the bottom and travel diagonally up the slope. In this way a windrow will be continually drifted to one side and will tend to fill low spots or irregularities.

When finishing in non-solid materials, such as earth, drag the blade backwards for a smooth job. Rock, of course, may damage the blade base, so such practice is not to be recommended where abrasive material is common.

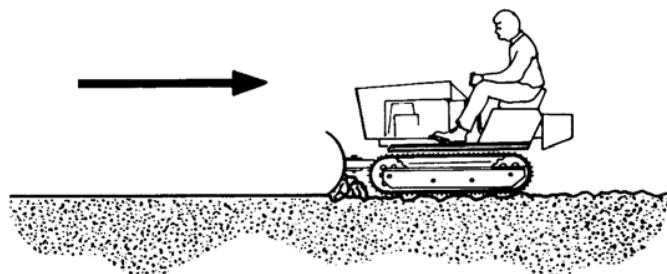

CRAWLER TIPS

For Safety & Dozing Success

Don't back up further than necessary and don't push earth for greater distances than required. These are common faults of inexperienced operators. Always have a plan of operation!

When dropping down a steep hill or over the side of a fill, use blade for a brake.

When traveling, carry the blade low. This practice helps protect drivetrain and other vital parts of the tractor.

If possible "slot doze" to keep load from spilling around the sides of the blade.

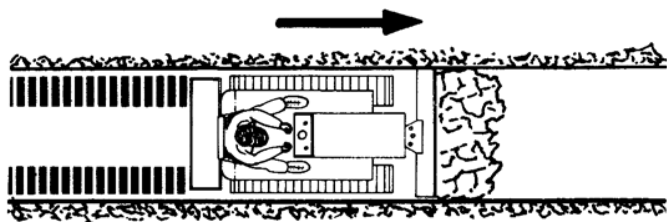

TECHNIQUES FOR COMPLETING VARIOUS PROPERTY IMPROVEMENTS

When enlarging ponds or streams, leave a ridge between the water and the excavation. When a desired depth is reached, dig out the ridge.

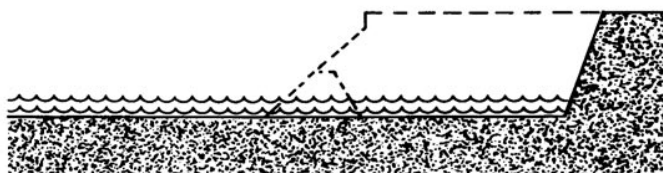
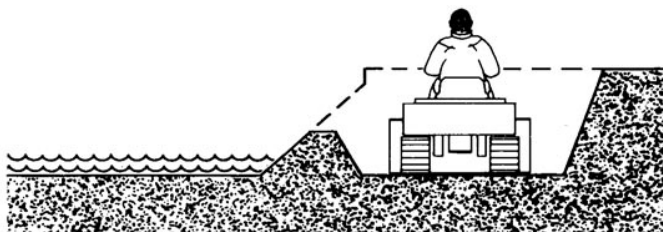
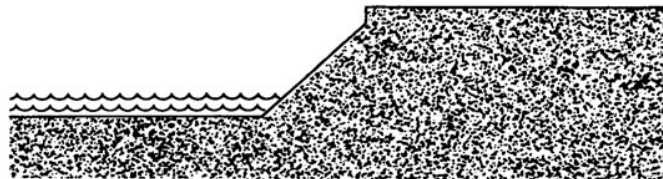

When excavating ponds or streams, leave a ridge between the water and the excavation. When a desired depth is reached, dig out the ridge.

When excavating wet soupy material construct a dry soil dike and place watery mud behind this structure to keep it from running back in the work area.

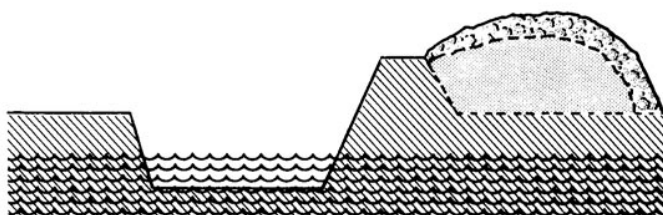
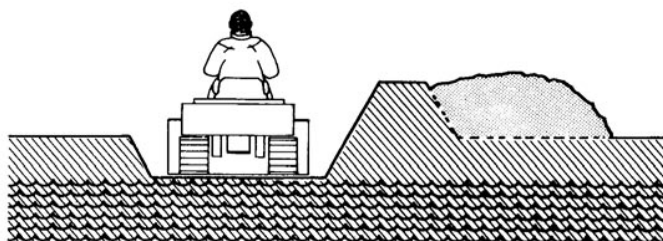
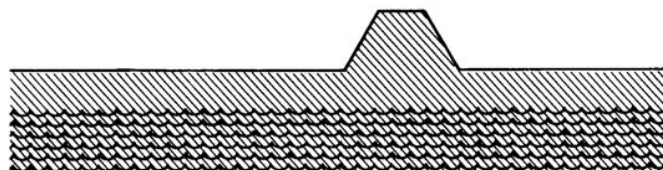

BACKHOE OPERATION

TERMINOLOGY

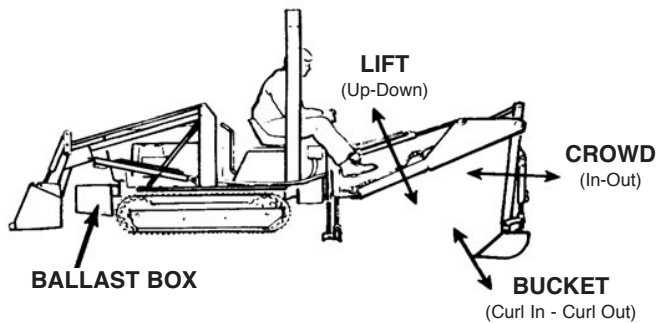
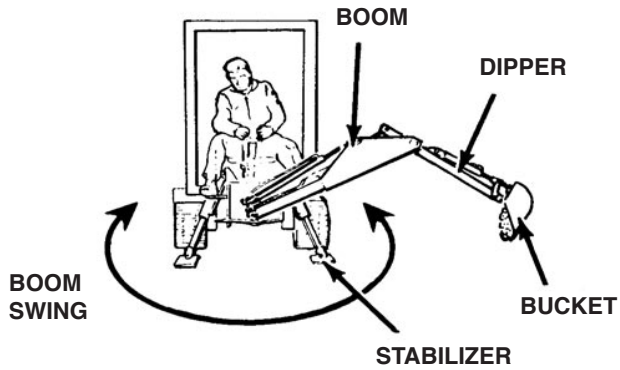

STABILITY

Stability is the key to backhoe performance. The following information and illustrations pertaining to stability should be carefully studied prior to operating the backhoe.

To increase stability for a digging operation, position the loader bucket flat on the ground. Apply sufficient down pressure on the bucket to transfer weight from the front of the tractor to the loader bucket.

IMPORTANT: The loader bucket must be flat on the ground. Rolling the bucket forward so the cylinders are extended may cause bucket cylinder or rod damage.

During normal digging, as the bucket penetrates the ground and is filled, there is a tendency for the rear of the Tractor to raise off the ground and move toward the bucket. Properly set, the stabilizers anchor the Tractor and prevent it from moving toward the bucket. The ability of the stabilizers to hold depends on the amount of weight

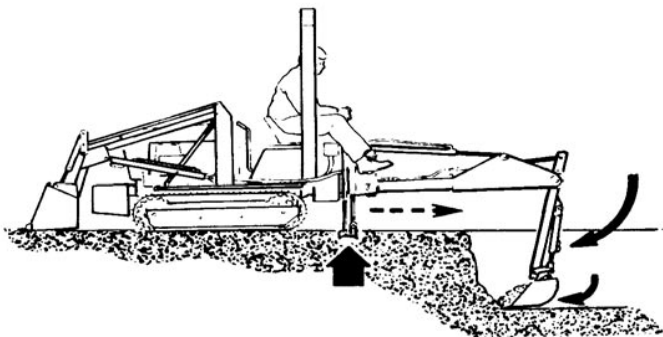

acting on them.

When lifting a full bucket, there is a tendency for the front of the tractor to rise. Counterweight in the form of a ballast box is required to overcome this tendency. The backhoe should not exert more lift force than the effective counterweight can balance. Effective counterweight is the weight of the tractor from the stabilizer pads to the loader.

Set the stabilizers to remove weight from the rear track wheels. The tracks are to remain touching the ground as this provides for the widest stabilizer stance and the lowest center of gravity. Raising the tracks off the ground will not only reduce stability and digging depth, but will impair performance and impose unnecessary stress on the unit.

Stability is particularly important when operating the backhoe at the extreme swing positions, because the ten-

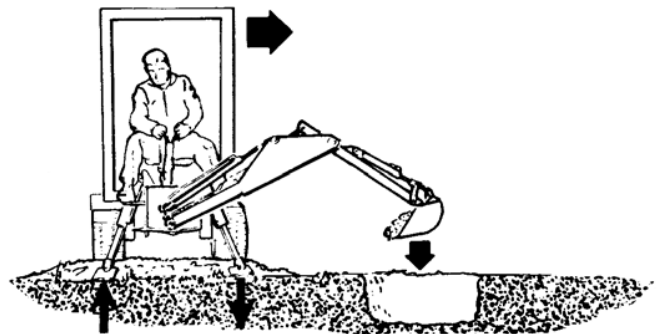

dency is to lift one stabilizer and transfer the total weight of the unit to the other stabilizer.

FILLING THE BUCKET

Operate two or more levers at the same time through-

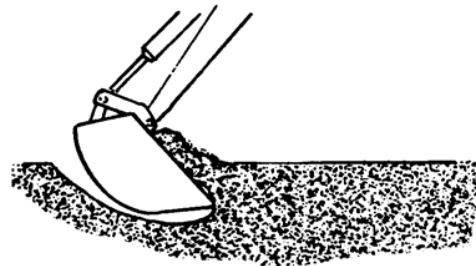

out the filling cycle for smooth action and maximum performance.

Control the bucket attitude throughout the digging cycle to keep the teeth at the proper angle for best penetration. This will minimize dragging and scraping the bucket through the ground.

When digging in hard-packed soil, bucket penetration can be increased by applying down pressure with the boom while crowding in and curling the bucket. If the crowd

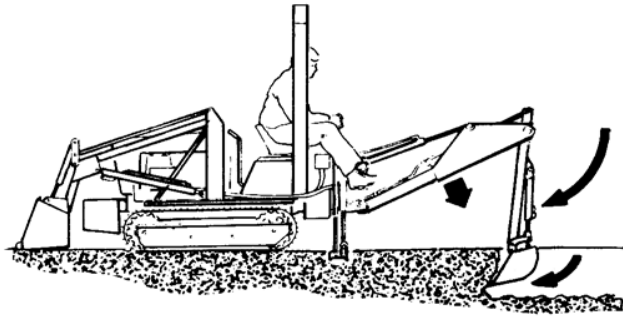

during the digging cycle to correct the bucket depth.

To obtain a cleaner trench and avoid the buildup of material directly in front of the backhoe, crowd out and completely curl the bucket while starting to lift it from the excavation. In this way, excess material will fall back into

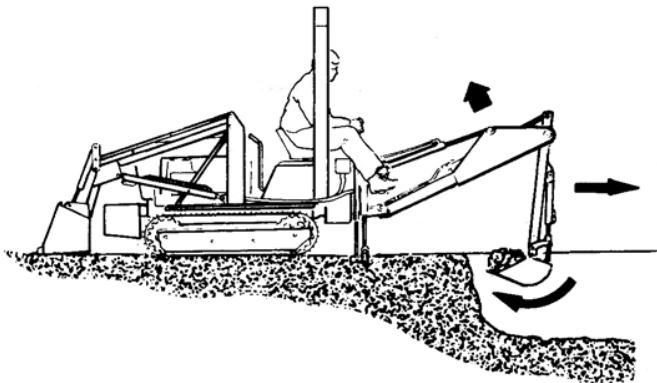

the excavation.

MOVING THE TRACTOR TO THE SIDE

Lift stabilizers clear of the ground, curl the bucket approximately halfway and crowd in so the dipstick is nearly vertical.

NOTE: The dipstick pivot, bucket pivot, and the point where the bucket contacts the ground should be aligned to reduce stress on the bucket and crowd cylinders.

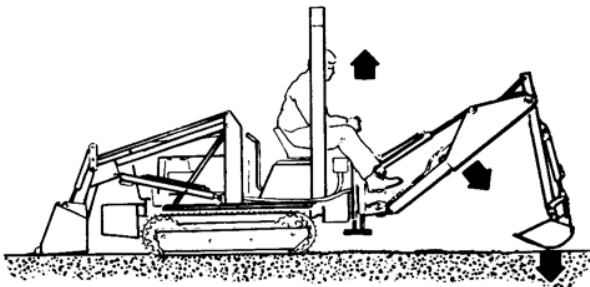

(Bucket forward of the boom-to-dipstick pivot).

Apply sufficient down pressure with the boom to raise the rear of the tracks off the ground. Slowly actuate the swing control lever to move to the right or left as required. Reset stabilizers and continue digging.

DUMPING THE BUCKET

To dump the bucket at the end of the digging cycle, lift the bucket clear of the trench while crowding it out and swinging it to the spoil pile.

As the pile is approached, dump the bucket. When the bucket is empty, the dipstick and bucket are in position to resume digging upon return to the trench.

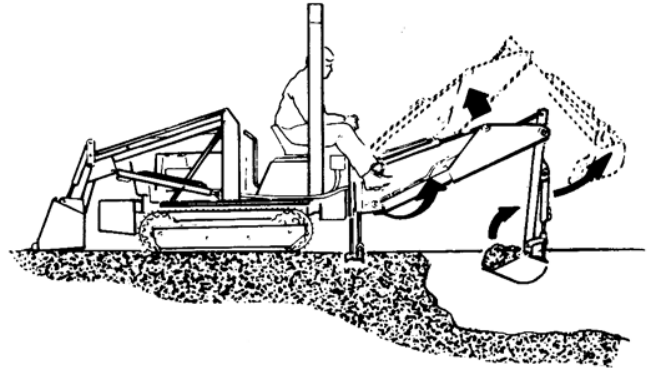

IMPORTANT: Avoid constant jarring or hammering type contact between the spoil pile and the loaded bucket as this may cause premature wear to the backhoe pins and bushings.

TRENCHING

Trenching is the most basic backhoe digging operation. Other digging operations are merely variations of this basic function (i.e. filling the bucket, dumping the bucket, and moving the unit forward).

While trenching, it is generally important to maintain a level trench bottom. This is accomplished by setting the bucket at the proper angle of approach. As the bucket is crowding in, continuously push on the bucket lever to maintain the correct cutting angle. At the same time, pull on the lift lever to relieve down pressure and keep the bucket in the same plane.

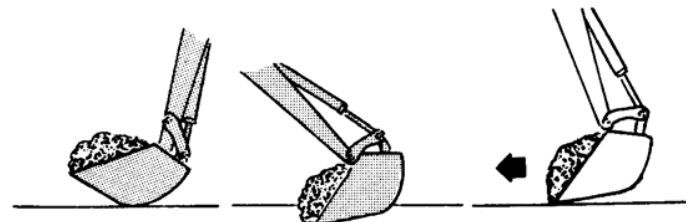

TRENCHING BETWEEN A BUILDING AND OPEN EXCAVATIONS.

Start the trench at the building. Trench out halfway to the excavation. Then, start trenching from excavation to the first trench. Dig toward the first trench until there is just enough room to move the unit out from between the two trenches.

Position the unit so the backhoe swing post is over the centerline of the trench connection. Dig with the backhoe at extreme swing position, and in close to the

stabilizers as possible. Pile the spoil on the opposite side of the trenches.

Continue the trench by moving the Tractor forward.

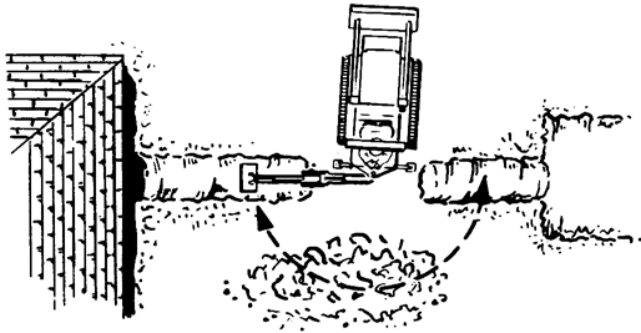

Moving too far will require excessive down pressure for digging, plus hand clean-up of the trench bottom. It is better to move a lesser amount than to move too far.

Position the unit forward so the two trenches can be connected. Pile the spoil on the opposite side of the trench.

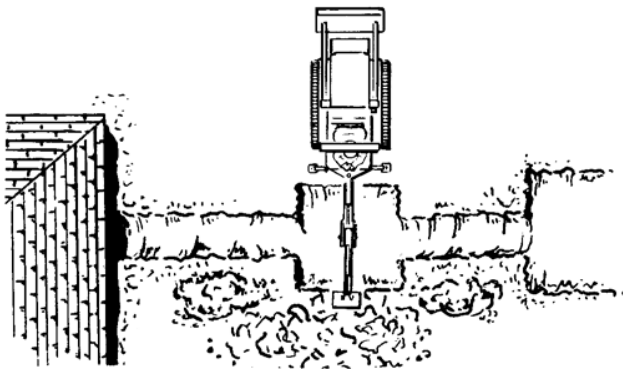

SIDE SLOPE EXCAVATING OR TRENCHING

Dig with the backhoe uphill whenever possible.

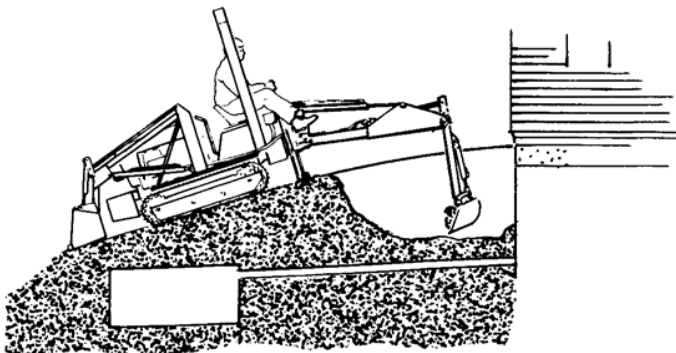

Level the backhoe on slopes with the stabilizers to dig plumb trenches, or...

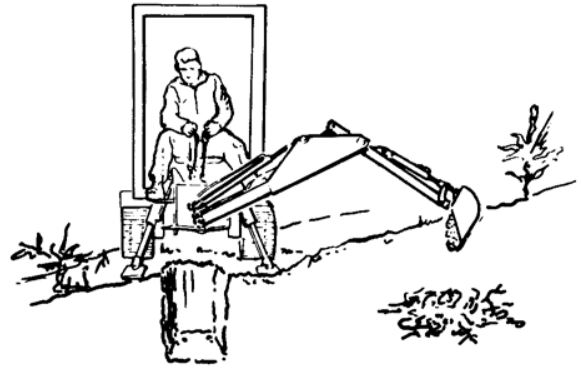

...use the backhoe or loader to cut a level slot for the uphill track and stabilizer. Pile ten spoil from the slot on the low side.

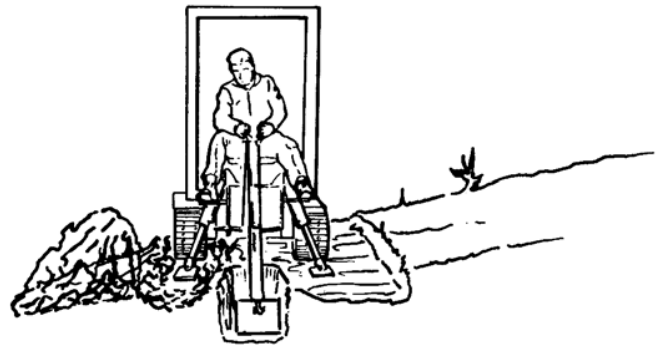

When on the side of a steep slope, cut a level surface along the uphill side of the trench with the loader. Pile the spoil of the cut downhill. When digging, pile the spoil

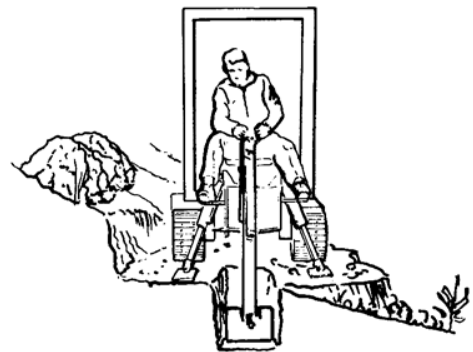

of the trench uphill.

Dig field tile trenches progressively. As soon as one trench is completed, have the workmen lay the tile. Start the next trench, using the spoil to fill the previous trench.

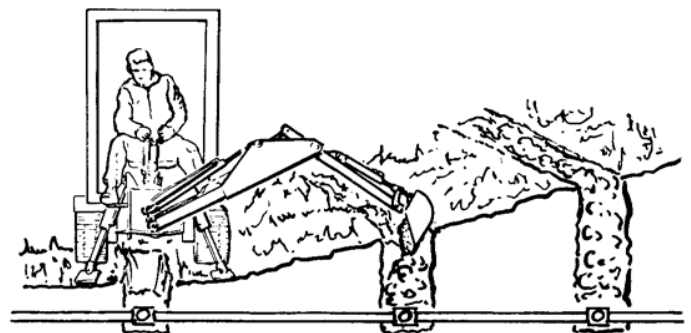

CONTINUOUS TRENCHING WITH SPACED BELL-HOLES

Begin by digging the trench to the desired grade. Progress along the trench to the bellhole locations and dig as much of the bellhole as possible without moving the backhoe from the trench line setting.

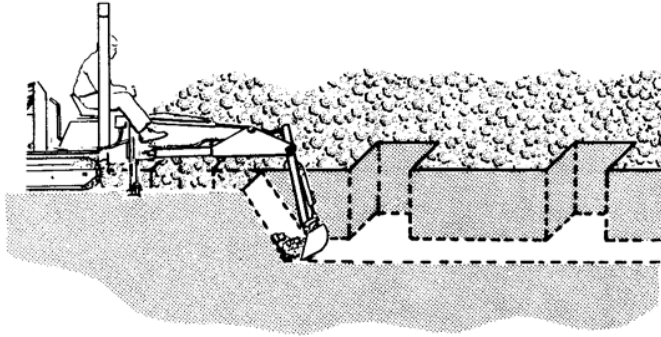

Move to the side as previously described and complete the bellhole. Realign the backhoe with the trench, and proceed trenching to the next bellhole.

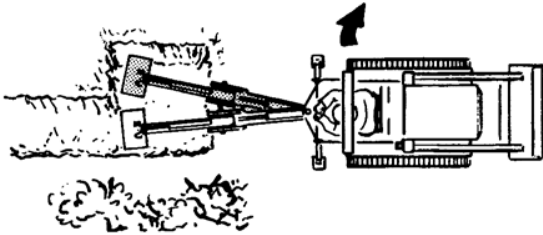

When finishing straight walls or bellholes in sandy soil, use a platform under the rear of tracks and the stabilizers. The platform distributes the load over a larger area and lessens the possibility of a cave-in. The platform also tends to keep the unit from creeping rearward if hard digging is encountered.

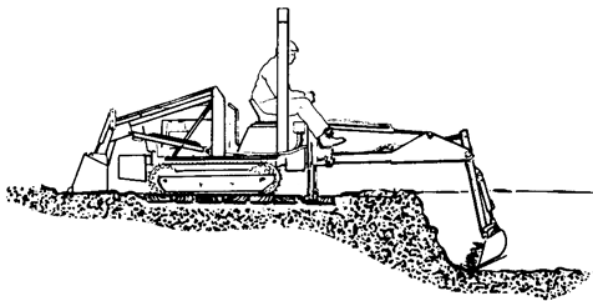

DIGGING STRAIGHT WALL SHALLOW BASEMENTS

Begin at one corner, removing as much material as possible to grade level. Then, reset the unit forward and continue digging to grade. Progress around the edge of the basement, finishing each corner as you come to it.

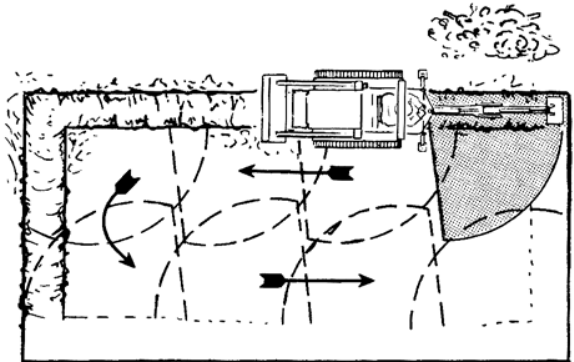

DIGGING UNDER A SIDEWALK OR CURB

To continue a trench or excavation under a sidewalk or curb, position the backhoe as shown.

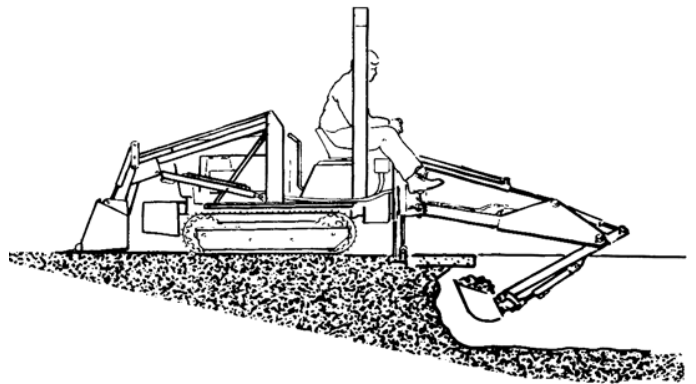

GRAVE DIGGING

For the best grave digging position, back the tractor straight in toward the grave site.

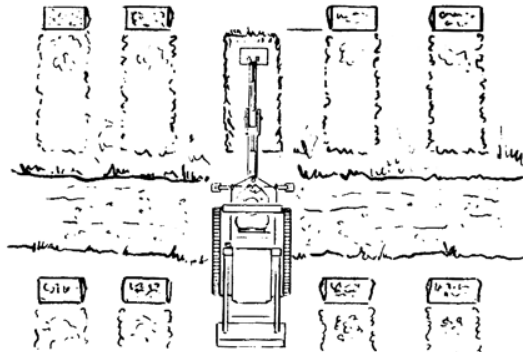

When grave markers prevent a straight-in position back the tractor in at a 45° or 90° angle to the grave site.

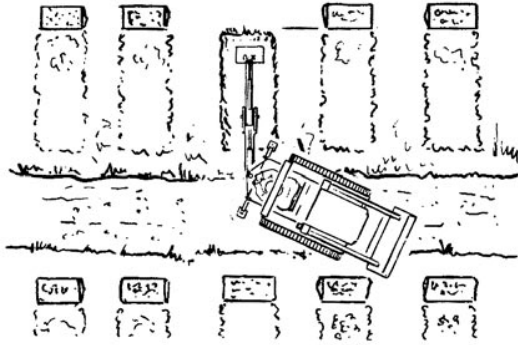

Position the tractor close enough to the grave to dig a full depth straight wall at the far end of the grave.

Start digging in the middle of the grave. At first, take shallow bites around the edges to avoid damage to the surrounding sod. After a one-foot (304.8 mm) depth is reached, full buckets can be removed, wherever possible.

When the desired depth is reached, finish the end walls. Finish the far wall by crowding out and forcing down.

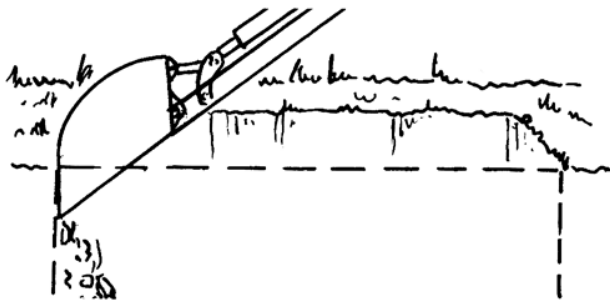

Lift up and crowd in to finish the close end wall.

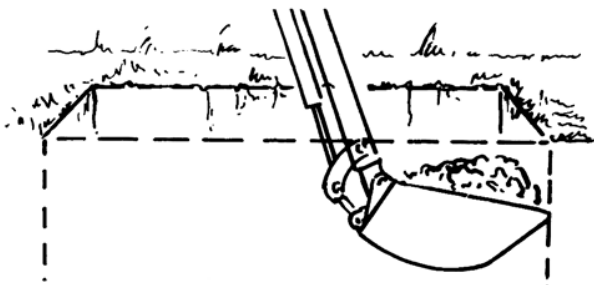

PIPELINE LEAK REPAIR

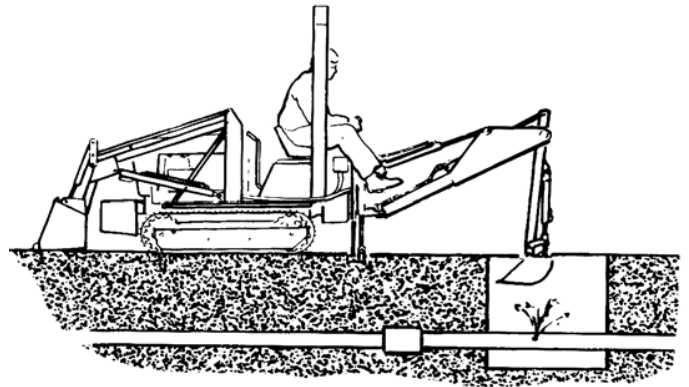

Locate the pipeline with a bellhole about six feet (182 cm) wide and ten feet (304 cm) long. Then dig lengthwise along the pipeline to locate the leak.

When the leak is located, position the unit to dig at grade level on both sides of the pipeline.

If a length of pipe must be replaced, strip the soil from both ends of the bellhole. Dig the bellhole or trench large enough to allow the workmen adequate space in the leak area.

BACKFILLING

Backfill by lifting the bucket over the spoil pile and then crowding in. Pull both the crowd and lift levers for smooth, even backfilling.



IMPORTANT: Do not backfill by using the swing circuit and dragging the bucket sideways. Doing so can cause damage to the dipstick, boom, swing cylinders, or main-frame.

MISCELLANEOUS

SNOW PLOWING

Snow is bulkier than dirt and its slippery consistency diminishes traction. When clearing snow, it is important to push the load to the back of the piling area because it cannot be reached again.

When snow is particularly heavy, paths can be cut with a straight blade in a herring bone pattern. Passes can be curving to the sides or straight and are stopped as soon as the load gets too heavy to push.

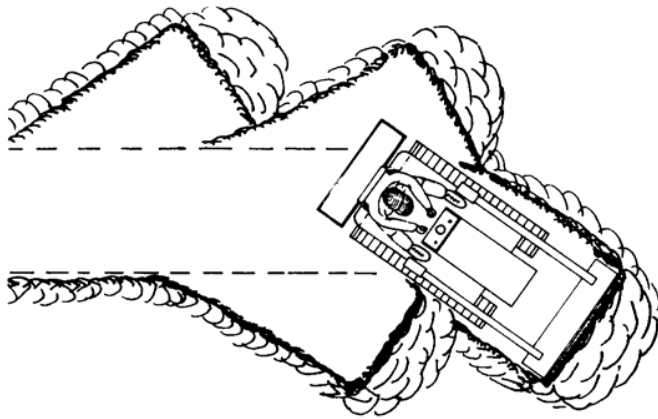

When plowing a garage drive, make consecutive passes to the side of the garage entrance, the obvious objective being to avoid piling snow against the door.

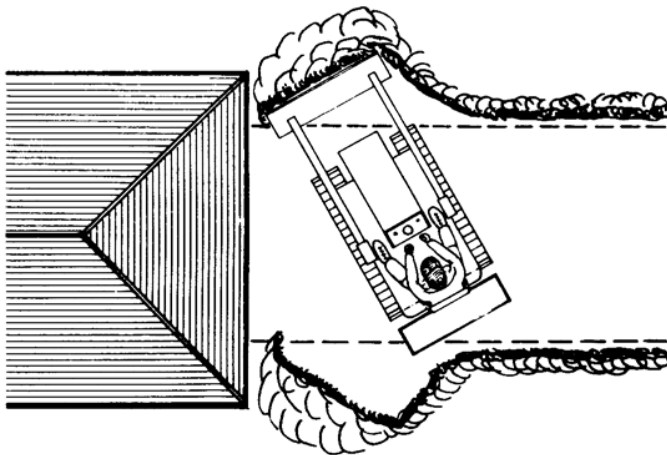

TREE REMOVAL

Light trees and brush are removed by lowering the blade a few inches into the ground just enough to strike and cut roots...usually done in first or second gear. An occasional backing up may be necessary to clear the blade so it can always cut cleanly. Otherwise the blade will slide over root and accomplish little.

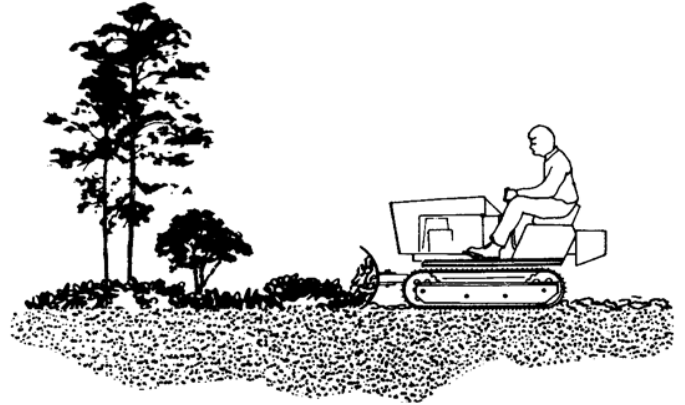

Heavier trees and brush require more care and time to uproot. First contact tree with blade high and centered for maximum leverage. Make contact gently...push a few times at half throttle while watching the top carefully. Look for dead limbs - they're widow makers! If tree seems in good condition open the throttle and try again.



Lower blade into the ground and doze exposed roots and tree completely clear of the ground.

To remove the larger trees follow a 3 step procedure: First, determine the direction of fall...usually in the direction of lean...and then make a few passes on the opposite side to a depth of say, 2 feet, or enough to cut some of the larger roots.

Second, cut roots on both adjacent sides in a similar manner.

Build an earth ramp up to the starting side of the tree to get still more leverage and then push. As the tree

starts over, reverse tractor quickly, for the roots pulling out of the ground may damage the machine. Next fill stump hole and then lift entire root section clear of the ground.

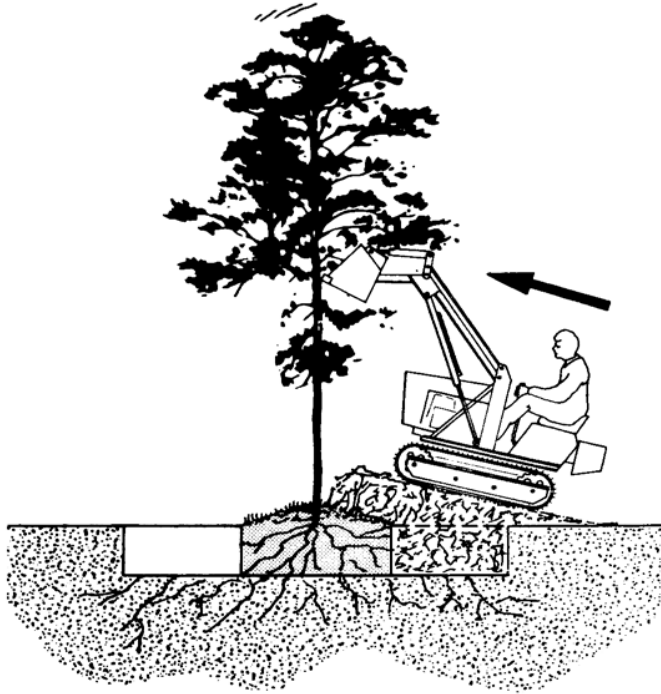

When the tree is too large to lift in a bucket, dig around the tree (as previously described) and then push it over the ground to its new destination. (Note below)

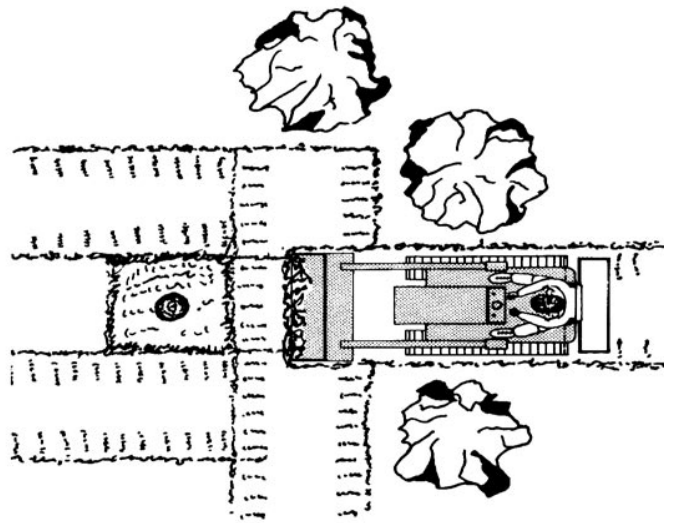

LOGGING

When pulling timber or poles, the front end should be lifted to maintain traction and reduce drag.



DON'T charge into big trees at full throttle. And don't push too long at a time. Track spinning is wasted effort.

TRANSPLANTING

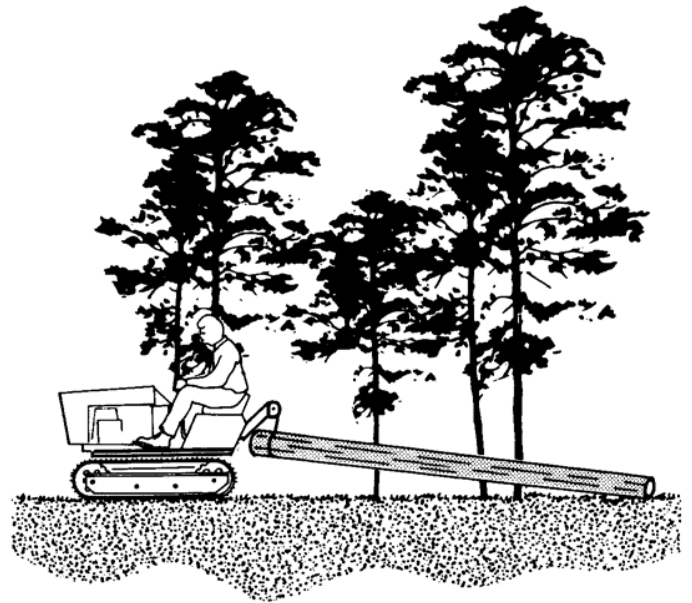

When transplanting trees of suitable size, place bucket under the dirt ball and lift it to a new site - securing the trunk to the bucket.

MOVING BOULDERS AND STONE

Dozers can move large rocks on firm ground perhaps several times its own weight. If the stone is too large for direct pushing, it can be pushed first on one side and then on the other.

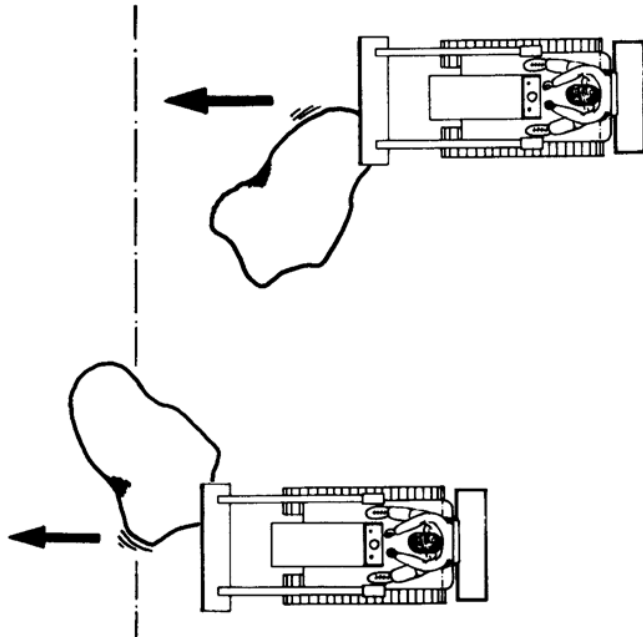

ROCKS

When a large rock is imbedded in a group of smaller ones, loosen and remove the smaller ones before attacking the big one. Operators should remember that if a rock doesn't move, something is holding it. Before proceeding, find cause and remedy it to prevent machine damage.

Many rocks such as shale and sandstone are found in tipped position. Always dig under the outcrop, lift, and break it out rather than try to penetrate from the opposite side. Sometimes driving a tractor on top will crush such rocks making removal easy.

STUMPS

Small dozers can tackle big stumps if you dig first. Make consecutive cuts around the stump until it is loose enough to pull out by a chain or blade.

Notch the stump and leverage it out using a log or railroad tie.

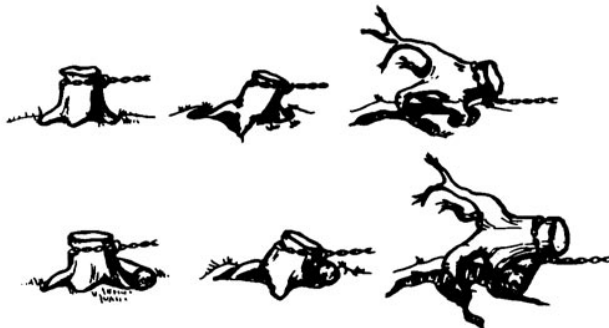

Part Number	Description	Qty
000060	Cap 830-FS-10	2
000070	Fitting, 844-FS-10	1
000114	Brace, Left	1
000115	Brace, Right	1
000208	Rocker Assembly, left	1
000213	Center Axle only (MH4800, MH5000, MH6000, MH7000, MH8000)	6
000214sfp	Rear Axle only (MH4800, MH5000, MH6000, MH7000, MH8000)	2
000215sfp	Front Axle only	2
000217A	#PK-5181 Yoke End 5/15-24 x 2-1/4" (If looking for pin that goes though yoke, see part #0025)	1
000219sfp	Pivot Rod	1
000222	Rocker Assembly, Right	1
000224sfp	Pull, brake, unpainted	4
000225L	Brake Caliper Assembly-Left	1
000225R	Brake Caliper Assembly-Right	1
000229L	Cover, Left	1
000229R	Cover, Right	1
000232sfp	Drive Chain Shim	24
000233	Spring, front axle, inside yellow, 4 3/4in. lng.	2
000234	Spring, front axle, Outside, Black, Green, 5in. lng.	2
000235sfp	Washer, 1-9/16" OD x 7/16" ID	16
000240	O-Ring, 1-1/8 "OD x 7/8" ID	36
000242	Washer, Steel, 1-1/2" OD x 7/8" ID x 18 gauge.	36
000243A	Shell	8
000243B	Bearing, 1-1/4" ID & Set Screw	4
000244	Pin, spring, 1/4" dia x 1-1/2"	6
000246sfp	Evener Rod, unpainted	1
000247	Pull Rod	1
000249	Support	1
000252A	Shell (single pc), 3 3/4" OD	4
000252B	Bearing with Collar & Set screws, 1" ID x 2" OD	2
000262sfp	Tube, spring stop, unpainted	4
000278	Grommet, 1"	3
000279	Grommet, Rubber 1 1/2"	2
000405	Bar (Replaces #272)	1
000413	Battery Strap	1
000428	Spring (4 1/2 long) MH4800, MH5000, MH6000, MH7000, MH8000)	1
000430	Choke Cable Assembly	1
000433	Clip, Coated	2
000436sfp	Shaft, 1-1/4" diameter	2
000440	Leaf Spring	1
000441	Switch, Sensing (interlock switch)	2
000442	Battery, 12 Volt, 350CCA, (MH5000, MH4800, MD567, MD200, MD750, RS1000)	1
000504sfp	Seat Pin, unpainted	1
000506	Spring, Compression	2
000515	Hose Assembly 1" x 14"	1
000522	Fitting, Barb, o-ring, 90 degree elbow	2
000527	Fitting, Straight, 848-FSO-10x10	2

000611	Fitting, 45 deg swivel, 889-FS-08	1
000616	Breather/Filter	1
000619	Fitting, KF10-06PS90	1
000622	Fitting, Barb, KF04-02PS	6
000676	Fitting, 90 deg, 879-FS-06	1
000704	Washer, Steel, 1-3/16" ID x 1-7/8" OD x 18 Gauge (REAR)	30
000705	Washer, Steel, 1-3/16" ID x 2-1/8 OD x 1/16, Hardened (FRONT)	20
000714	Key, 1/4" square x 1-3/4"	2
000716	Washer, Steel, 1" ID x 1-1/2" OD	50
000722	Guard	2
000723	Washer, steel, 1-1/4 ID x 1-7/8 OD x 18 gauge.	30
000727	Snap Ring, 1-3/16" ID	6
000728-C	Snap Ring, 7/8" ID (Coiled - Type) (used on MH Series)	6
000817	Fitting, "T", 871-FS-06	1
000851	Fitting, 90 deg. 849-FSO-10X10	5
000872	Roll Pin, 1/4 x 2, double roll	4
000873	Roll Pin, 3/16" x 2" Coiled Spring	2
000874	Key	2
000904	Foot Pad, Non-skid	4
000931	Hose Clamp, 5/8"	2
000932	Hose Clamp 1"	6
000933A	Seat only - 7.5 x 7 Bolt Pattern (Z bracket is needed to match the 8 x 10 design)	1
000973	Fitting 854-FS-06x04	1
001030sfp	1/2" Track Tension Rod - 12 1/4" long from end to end, 11 9/16" long from bottom of nut to e	4
001041R-2	Salami- R20276730 - KIT TRASFORMAZIONE DA CE A CW (BACK-UP ALARM TRANSFORMER)	1
001043	#16-16MP Fitting, Barb	1
001083	Tee, 1-1/4 x 1/2 x 1	1
001090	80HZ-030 Roller Chain does not include Connector Link	2
001091	#80 Master Connector Link	2
001122	Fitting, 879-FS-10	3
001124	Fitting, 848-FSO-10 x 08	2
001204Csfp	#CA557 Track Section	4
001210	Lower Track Frame	1
001211	Axle Support for Rear Axle (MH5000 Serial #'s H1380 and after, MH4800, MH7000, MH8000)	4
001218XX	Center Idler, 4 1/2", with bushings, (MH4800, MH7000, MH8000) - (MT2000, MT3000, MH500)	6
001221	Cover	2
001235	Snap ring, 1/2 in	4
001251	Fitting, 4603-16x12	1
001364	Rubber Hood Latch	2
001457	1/8" TEE - BIP	1
001523	Zerk, 1/8" NPT, 45 Degree	2
001870	Rivet, 3/16, (.126-.250) (.192-.196), AD64ABS200	4
001905	Clamp, vinyl coated, 1"	2
001908	3/16 X 1 3/4 Cotter Pin	4
001990	Hose Clamp	2
002061	Zerk, grease fitting, 1/8 NPT	8
002071	Protective cap, red, battery	2

002583	Thin shim washer - 5/8 x 1" 18GA	27
004002L	004002L Left Brake Mount	1
004002R	004002R Right Brake Mount Painted	1
004005	Disk Drive	2
004006	Primary Drive	2
004007	#60 Chain including Connector Link	2
004008L	004008L Left Rear Fender Support, painted	1
004008R	004008R Right Rear Fender Support, painted	1
004009L	004009L Front fender support, left, painted	1
004009R	004009R Front Fender Support, right, painted	1
004013	004013 Valve Angle	1
004014	004014 Valve mount plate, painted	1
004015L	004015L Left side panel, painted	1
004015R	004015R Right side panel, painted	1
004021	004021 Side shield, painted	1
004022	004022 Valve cover, painted	1
004023	Rear gas tank bracket, painted	1
004024	Front Mount, painted	1
004025	004025 Seat pan, painted	1
004029	004029 Oil Filter Mount	1
004039	004039 Treadle	1
004048	004048 Side Panel, left	1
004049	004049 Side Panel	1
004062	Cable Tie, 40" Long	2
004162	3/16" Fuel Line Hose for Gas Tank	1
004163	Hose Clamp	2
004196	1/8" Closed Nipple - BIP	1
004198	Right Angle Reducing Tee - BIP 1" x 1" x 1/2"	1
004199	3/4" - 90 Degree - BIP	1
004200	Hub Shaft for Flo Torq Motor	2
004201L	Flo Torq Motor Mount, Left, painted	1
004201R	Flo Torq Motor Mount, Right, painted	1
004202L	Flo Torq Motor Box, Left, no pin, painted	1
004202R	Flo Torq Motor Box, Right, no pin, painted	1
004203	New Upper Frame, MH4900, Painted	1
004204	Mount, MH4900, Painted	1
004205	Plate, MH4900, Painted	1
004206	Leg, MH4900, Painted	2
004207	Floor, MH4900, Painted	1
004208	Mount, MH4900, Painted	1
004209	Pivot, MH4900, Painted	1
004210sfp	Threaded Rod, Unpainted	1
004211	Link, MH4900, Painted	1
004215sfp	Hub, Unpainted	1
004216	Dash Control Mount, MH4900, Painted	1
004218	Dash Enclosure, MH4900, Painted	1
004221	Lever Assembly, MH4900, Painted	2

004223L	Left Fender, painted (MH4900)	1
004223R	Right Fender, painted (MH4900)	1
004224	Front Idler, 1/4", w/paint, bushings and grease fitting, (MH4900)	2
004225	Rear Drive, 1/4", painted, bushings, grease fitting (MH4900)	2
004228XX	Red wire, + battery to starter, 6 GA red x 43"	1
004229XX	Black wire, 6 GA x 36" - Battery to Engine ground	1
004230	Oil Temp Sensor	1
004231	Oil Temp Gauge	1
004232	Key, 3/8 x 3/8 x 1-3/8"	1
004233sfp	Hub, Unpainted	1
004235	Flo-Torq Hydraulic Motors	2
004236	5 Gal Low Profile CARB Tank Assy Kit Honda Tank Kit Packed 1 kit per box	1
004237	Honda GX690 (MH4900)	1
004238	#TF-GBBB-GBBA-46PL Hydrogear Tandem Pump (MH4900)	1
004239	#MA-4-213336 Heat Exchanger (Oil Cooler - MH4900)	1
004240	#10312-816-45 Vonberg Check Valve	1
004241	Turollo Gear Pump - 10GPM -(MH4900)	1
004242	Hydraulic Filter (MH4900)	1
004243	#P166417 Filter Head	1
004244	#M30011612 Magnaloy Hub (Engine Side)	1
004245	#M300A1316C Magnaloy Hub (Pump Side)	1
004246	#M370H5 Coupling Insert	1
004248	Throttle Handle	1
004249	Disc Spring	2
004250	Plastic Washer	2
004252	Rubber Bumper	4
004254XX	Soft Hose, tank suction to attachmnet pump, 1" x 6 1/4"	1
004255XX	Soft Hose, piston pump case drain, 5/8" x 4 1/2"	1
004256XX	Soft Hose, breather to tank vent, 1/4" x 27"	1
004257XX	Soft Hose, breather to rear tank vent, 1/4" x 36"	1
004258	Hose 5/8" x 27 3/4", Check Valve to Oil Cooler	1
004259XX	Soft Hose, oil cooler to tank dump, 1" x 25"	1
004260	Pedal Assembly, Painted	1
004261	Pull Rod Assembly, Painted	1
004265	Seat Post Upper - painted	1
004266	Seat PLate Lower - painted	1
004279	Hose, Rear attachment to HC74 "T" fitting, 1/2-13 1/2"	1
004280	Hose, Left track top piston pump to left track 1 port, 1/2-22"	1
004281	Hose, Left track bottom piston pump to left track 2 port, 1/2-19"	1
004282	Hose, Right track top piston pump to right track 3 port, 1/2 x 9 1/2"	1
004283	Hose, Right track bottom piston pump to right track 4 port, 1/2 x 11 1/2"	1
004284XX	Soft Hose, track motor case drain, 1/4" x 6 1/2"	2
004285	Hose, check valve to piston pump, 1/4" x 9 1/2"	1
004286	Hose, Attachment pump to attachment valve, 1/2 x 42"	1
004300	Fitting 848-FSO-10X16	1
004301	Fitting, 6815-16x16	1
004302	Fitting, 849-FSO-10X16	2

004303	4601-16-16	1
004304	Fittings 60SB-08X06	1
004305	4503-16X12	1
004306	Fitting, 849-FSO-10X08	2
004307	848-FSO-06X06	1
004308	1027V	2
004309	8160V	3
004331XX	Attachment /loader valve assembly, (5 bank, MH4900 with relief valve)	1
004332	Hose, Attachment valve to HC74 "T" fitting, 1/2 x 40" (HC74 hose)	1
004335	Hose, Aux - 2 on attachmnet valve to rear attachment, 1/2 x 47" (HC74 hose)	1
004361XX	Blue wire, oil temp gauge to oil temp sensor, 14 GA x 6 (MH4900)	1
004362XX	Green wire, oil temp sensor to ground, 14 GA x 18" (MH4900)	1
004363XX	Black wire, oil temp gauge to ground, 14 GA x 39" (MH4900)	1
004364XX	Gray wire, seat to black/yellow wire on honda harness, 14 GA x 60" (MH4900)	1
004365XX	Gray wire, seat to ignition, 14 GA x 60" (MH4900)	1
004366XX	Yellow wire, attachment valve safety switch to brake safety switch, 14 GA x 19" (MH4900)	1
004367XX	Yellow wire, ignition switch to brake safety switch, 14 GA x 65" (MH4900)	1
004368XX	Yellow wire, attachment safety switch to Honda wire harness, 14 GA x 70" (MH4900)	1
BOLT-1/2-133	1/2-13X1 SPIN LOCK BLT	13
BOLT-1/2-134	1/2-13X1 1/2 SPIN LOCK BLT	8
BOLT-1/2-31	1/2 - 13 X 1 G5 BOLT	4
BOLT-1/2-92	1/2-13X1 1/2 G5 CARR BLT ZC	4
BOLT-1/4-118	1/4-20X 1/2 HX SPIN LOCK BLT	10
BOLT-1/4-119	1/4-20X 3/4 HX SPIN LOCK BLT	2
BOLT-1/4-3	1/4-20X 1 G5 BOLT	4
BOLT-1/4-4	1/4-20X 1 1/4 G5 BOLT	1
BOLT-10-24-189	10-24X 3/4 HX HD MACHINE SCREW	1
BOLT-3/8-127	3/8-16X3/4 SPIN LOCK BLT	14
BOLT-3/8-128	3/8-16X1 SPIN LOCK BLT	6
BOLT-3/8-186	3/8-16 X 1/2" HH Machine Screw	2
BOLT-3/8-24	3/8 - 16 X 2 G5 BOLT	2
BOLT-3/8-28	3/8 - 16 X 4 G5 BOLT	2
BOLT-3/8-87	3/8-16X3/4 G5 CARR BLT ZC	38
BOLT-3/8-88	3/8-16X1 1/4 CARR BLT ZC	4
BOLT-5/16-11	5/16 - 18 X 2 1/2 G5 BOLT	3
BOLT-5/16-12	5/16-18 X 3 G5 BOLT	1
BOLT-5/16-121	5/16-18X 3/4 SPIN LOCK BLT	56
BOLT-5/16-121	5/16-18X 3/4 SPIN LOCK BLT	23
BOLT-5/16-124	5/16-18X 1 1/4 HX SPIN LOCK BLT	6
BOLT-5/16-125	5/16-18X 1 1/2 HX SPIN LOCK BLT	5
BOLT-5/16-127	5/16-18 x 1/2 Spinlock Bolt	10
BOLT-5/16-14	5/16-18 X 4 G5 BOLT	2
BOLT-5/16-19	5/16 - 18 X 1/2 G5 BOLT	4
BOLT-5/16-193	5/16-18X 3/4 HX W/HD THRD CUT TYPE F SELF TAPPER	4
BOLT-5/16-7	5/16-18 X 1 G5 BOLT	2
BOLT-5/16-83	5/16-18X3/4 G5 CARR BLT ZC	21
BOLT-5/16-84	5/16-18X1 G5 CARR BLT ZC	1

BOLT-5/16-9	5/16-18 X 1 3/4 G5 BOLT	3
BOLT-5/16-9	5/16-18 X 1 3/4 G5 BOLT	1
BOLT-8-32-303	8-32X 1/2 Bolt	8
BOLT-M8-1.25-290	8mm x 1.25 pitch (30mm) Socket HEX HD - Plain	3
DEC-MH4900	DECALS FOR THE MH4900	1
MAT-000274	Black Edging with steel insert/per foot	1
NUT-1/2-211	1/2-20 G8 HX FINE THREAD NUT	8
NUT-1/2-234	1/2-13 SPIN LOCK NUT	20
NUT-1/2-244	1/2-13 DOT LOCK NUT	4
NUT-1/4-220	1/4-20 NYLON LOCK NUT	5
NUT-1/4-230	1/4-20 SPIN LOCK NUT	6
NUT-1/4-230	1/4-20 SPIN LOCK NUT	6
NUT-10-24-219	10-24 NYLON LOCK NUT	1
NUT-3/8-222	3/8-16 Nylon Lock Nut	2
NUT-3/8-232	3/8-16 SPIN LOCK NUT	66
NUT-3/8-243	3/8-16 DOT LOCK NUT	2
NUT-5/16-221	5/16-18 NYLON LOCK NUT	10
NUT-5/16-231	5/16-18 SPIN LOCK NUT	80
NUT-5/16-231	5/16-18 SPIN LOCK NUT	22
NUT-8-32-218	8-32 NYLON LOCK NUT	4
SETSCW-1/4-177	1/4-28X3/8 SET SCREW	4
SETSCW-3/8-174	3/8-16X1/2 SET SCREW	2
SETSCW-5/16-178	5/16-24X1/2 SET SCREW	2
WASH-1/4-260	1/4 FLAT WASHER	1
WASH-3/8-282	3/8 Star Washer	4
WASH-3/8-286	3/8 X 1 1/2 FEND WASHER ZC, (BIGGER OD)	2
WASH-5/16-261	5/16 FLAT WASHER	3
WASH-5/16-261	5/16 FLAT WASHER	14

Photos

Left side is referenced as **driver's left side** of the MAGNATRAC.

Right side is referenced as **driver's right side** of the MAGNATRAC.

Photo Number	Description	Photo Number	Description
MH-1	Overview - no attachments	MH-21	Hydraulics - right side (closeup)
MH-2	Overview - right side	MH-22	Hydraulics - piston pump (left & right)
MH-3	Overview - left front	MH-23	Hydraulics - filter assembly
MH-4	Console View	MH-24	Hydraulics - attachment valve
MH-5	Seat View	MH-25	Hydraulics - hydraulic diagram
MH-6	Parking Brake - drawing	MH-26	Drive - top rear view
MH-7	Parking Brake - right view	MH-27	Drive - motor view (closeup)
MH-8	Throttle Linkage view	MH-28	Drive - top right side view
MH-9	Engine - front view	MH-29	Drive - inside right view
MH-10	Engine - left view	MH-30	Drive - disk drive view
MH-11	Engine - top view	MH-31	Drive - primary drive view
MH-12	Engine - right view	MH-32	Drive - outside right view
MH-13	Engine - fan view	MH-33	Drive - inside right view
MH-14	Electrical - behind dash view	MH-34	Track - lower frame view
MH-15	Electrical - wiring diagram	MH-35	Track - upper & lower box view
MH-16	Fuel - tank view	MH-36	Track - right outside view
MH-17	Fuel - carbon filter view	MH-37	Track - right front view
MH-18	Hydraulics - left side view	MH-38	Track - right side view
MH-19	Hydraulics - upper left side view	MH-39	Track - right rear view
MH-20	Hydraulics - right side view	MH-40	Track - left inside view