



# MAGNATRAC®

## Compact Crawler Tractors

### BUYER'S GUIDE - MH Series

# MH4900

# MH8000

## MH4900 - Homesteader

**MAGNATRAC® MH4900** - Assembled.

Includes 690cc (**approx. 22 HP**) HONDA Engine. "V" twin cylinder air cooled gasoline engine with overhead valves, electric starting, and 17 amp alternator. Tandem piston pump hydrostatic drive system with standard 5 bank Attachment Control Valve and standard-duty seat. Standard-duty track system with 3 idlers per side and CA557 track chain.

Track Shoes **not** included - see Track Shoe Kits for the most traction (page 2). [NOTE: *Track System Upgrade* available... **TSU551 - Track System grade Upgrade**, and anniversary upgrade available... **UG50 - 50th Anniversary Upgrade**, see the MH4900 brochure or speak with a sales rep for more information on these upgrades.] MH4900 shown with optional TSO40 Grouser Track Shoes and UG50 50th Anniversary Upgrade.

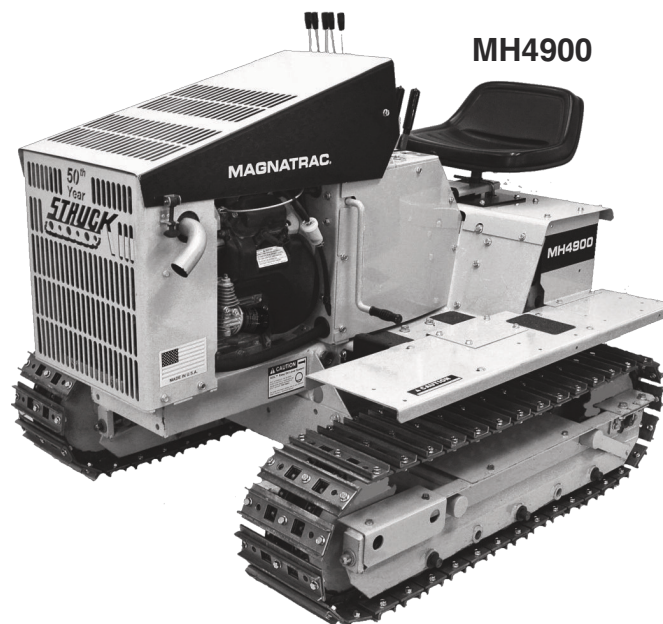

**MH4900 - Magnatrac Hydro** (Base weight only). . . . . 1,700 lbs.

MH8000

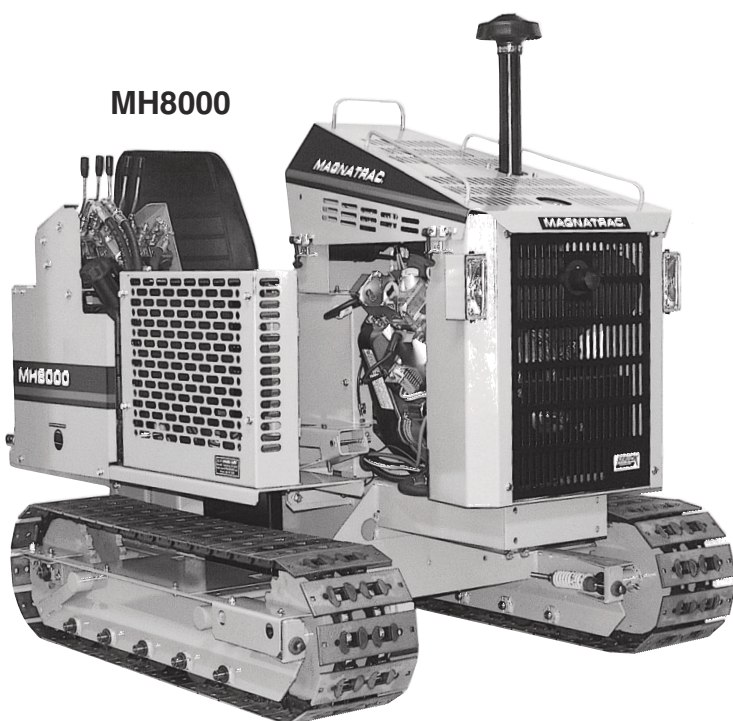

## MH8000 - Contractor

**MAGNATRAC® MH8000** - Assembled.

Includes 895cc (**approx. 31 HP**) Briggs & Stratton Vanguard Commercial Engine. "V" twin cylinder air-cooled gasoline engine with overhead valves, electric starting, 20 amp alternator, full pressure lubrication, and 5" centrifugal multi-stage air cleaner. Dual pump hydraulic system with standard 5 bank attachment control valve and high back contractor grade seat. Hour meter, hydraulic oil temp gauge, amp meter, and dual halogen headlights included. Heavy-duty track system with 5 idlers per side, protective idler collars and heavy-duty CA551X track chain for rocky and sandy environments.

Track Shoes **not** included - see Track Shoe Kits for the most traction (page 2). [NOTE: *35 HP Briggs & Stratton Vanguard Engine Upgrade* available... **ENG35 - 35HP Engine Upgrade**, page 2.]

**MH8000 - Magnatrac Hydro** (Base weight only). . . . . 2,100 lbs.



# Accessories & Track Shoes



ENG35

## ENG35 35HP Engine Upgrade Package

- Assembled.

35 HP Engine Upgrade Package provides maximum workpower! It also boasts full pressure lubrication, cast iron cylinder sleeves, commercial grade starter, 20 amp alternator and a 5" Donaldson multistage air cleaner. **[MH8000 only]**

**ENG35 35HP Engine Upgrade**

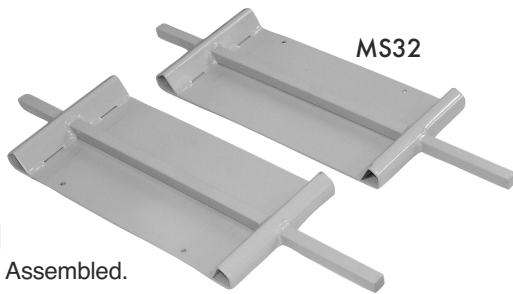

MS32

## MS32 Mud Scrapers

- Assembled.

Replaces standard track covers with heavy-duty covers incorporating 1" thick solid steel bars to prevent mud and ice build-up between track sprockets.

**MS32 Mud Scrapers Kit** . . . . . 85 lbs.

## HC74 Hydraulic Circuit - Assembled.

Standard on MH8000. Optional on MH4900. Complete with hoses, fittings, power beyond plug, rotary valve and all mounting and electrical safety switch hardware. This Hydraulic Circuit is required for operation of PTO70 POWER TAKEOFF and SKID STEER ATTACHMENTS and can also be used for powering NH3A REMOTE AUGER DRIVE or other 3rd party attachments...check with factory for proper applications.

**HC74 Hydraulic Circuit Kit** (not shown) . . . (Factory Option Only) . . . . . 21 lbs.

**NOTE:** Though Track Shoes are **strongly recommended**, and provide greatest traction and stiffen Track Pads for working in rock, Magnatracs not so equipped will still pull about 80% of crawler's rated drawbar ability.

## TSO40 Steel Grouser Track Shoe Kit

Replaceable, channel-shaped Steel Grouser Shoes provide the ultimate in traction. These all-steel shoes will go through mud and bite into the hardest ground for maximum traction. **[Factory assembly available]**

**TSO40 Steel Grouser Track Shoe Kit** . . . . . 75 lbs.

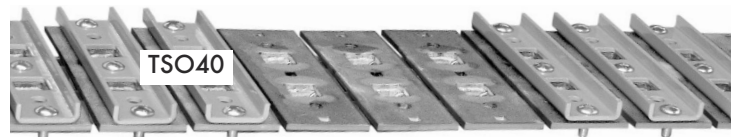

## TSO45P Non-Marking Track Shoe Kit

Made of 3/4" thick blocks of UHMW Polyethylene encased in all-steel channels, Non-Marking Track Shoes give you traction in soft going while protecting concrete and asphalt. **[Factory assembly available]**  
**NOT RECOMMENDED FOR USE ON ICE & SNOW.**

**TSO45P Non-Marking Track Shoe Kit** . . . . . 118 lbs.

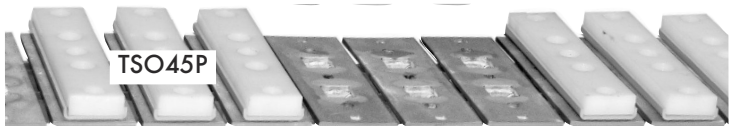

## TK551X Track Set Kit & TK557 Track Set Kit

Set of *Original Equipment* Tracks. Buy a second set of Tracks for complete versatility. Today you need the tough bite of Grouser Shoes, next week the forgiving touch of Non-Marking Shoes. Switch Tracks, not Shoes!

**TK551X Track Set Kit** (pair) (MH4900 or MH8000). . . . . 220 lbs.

**TK557 Track Set Kit** (pair) (MH4900). . . . . 190 lbs.

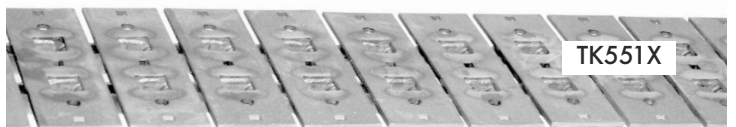

ROPS85

## ROPS85 Roll-Over Protective Structure

- Assembled.

**\*\* According to Federal Laws, no tractor can be operated by employees without a Roll-Over Protective Structure!**

Safety-First! Even a MAGNATRAC'S low center of gravity and ground-gripping traction are no substitute for Roll Over Protection (ROPS) on slopes and uneven ground. Includes: seat belt, installation hardware and special seat pan and mount to accommodate the ROPS to the rear of the MAGNATRAC.

**ROPS85 Roll-Over Protective Structure Kit** . . 465 lbs.

For operator safety, a **ROLL-OVER PROTECTIVE STRUCTURE** is strongly recommended for all MH Series MAGNATRACS!



# Specifications & Ratings

## MH4900

## MH8000

<b>Engine</b>	688cc, 22 HP Honda GX690, "V" twin cylinders [Gasoline Engine]
<b>Air Cleaner</b>	Paper element, oiled foam precleaner
<b>Track Drive</b>	1.33 in <sup>3</sup> per rev., Dedicated 19.6 GPM @ 3600 RPM
<b>Attachment Pump</b>	0.66 in <sup>3</sup> per rev., Dedicated 10 GPM @ 3600 RPM
<b>Fuel Tank</b>	Remote with fuel pump, 5+ gal. capacity,
<b>Hydraulic Oil Cooler</b>	Internally mounted, engine fan cooled 9" Fan with 425 CFM.
<b>Attachment Valve</b>	Five (5) bank sectional valve
<b>Track Motors</b>	125cc or 7.67 in <sup>3</sup> per revolution
<b>Travel Speeds</b>	Variable Regular Drive.....0 - 2.5 MPH
<b>Instrumentation</b>	Optional (See UG50 50th Anniversary Upgrade)
<b>Chain Sprockets</b>	Induction hardened steel
<b>Track Sprockets</b>	1/4" thick AR200 pre-hardened steel, plasma cut
<b>Track Rollers</b>	4-1/2" diameter, 5/8" thick flanges, Solid steel (3) per side
<b>Track Chain</b>	Double lengths #CA557 Chain, 30,000 ultimate strength per Track (Upgrade available - See TSU551)
<b>Track Shoes</b>	9-1/2" wide, 7/16" diameter overall laminated thickness Grouser and Non-Marking options
<b>Primary Drive Chain</b>	60R, 9,200 lbs. tensile strength
<b>Final Drive Chain</b>	80HK, 22,046 lbs. tensile strength
<b>Axle Diameters</b>	7/8" dia. on Idlers; 1-3/16" diameter on Track Sprockets
<b>Park &amp; Emgr. Brake</b>	Dual 8" diameter disk type
<b>Battery</b>	295 CCA
<b>Base Weight</b>	1,700 lbs. with no attachments
<b>Track Tensioning</b>	Industrial grade coiled steel springs (4)
<b>Track Ground Contact</b>	5.36 sq. ft.
<b>Seat</b>	Standard-duty, Rotatable, height settings with Pin.
<b>HC74 Hydro Circuit</b>	Optional
<b>PTO</b>	Optional, 1 3/8" dia., 6 splined, 540 RPM, approx. 15 hp

895cc, 31 HP Vanguard, "V" twin cylinders [Gasoline Engine] (35 HP Upgrade available)
5" Donaldson cyclonic multi-stage
1.01 in <sup>3</sup> per rev., 15.7 GPM @ 3600 RPM
0.500 in <sup>3</sup> per rev., 7.8 GPM @ 3600 RPM
Remote with fuel pump, 5+ gal. capacity
Externally mounted, engine fan cooled 16" Fan with 1550 CFM.
Five (5) bank sectional valve
160cc or 9.6 in <sup>3</sup> per revolution
Variable Regular Drive.....0 - 2.4 MPH
Variable Hi Drive.....0 - 3.5 MPH
Hydraulic oil temp. amp & hour gauges
Induction hardened steel
5/8" thick AR200 pre-hardened steel, plasma cut
4-1/2" diameter, 5/8" thick flanges, Solid steel (5) per side
Double lengths #CA551X Chain, 40,000 ultimate strength per Track
9-1/2" wide, 7/16" diameter overall laminated thickness, Grouser and Non-Marking options
60R, 9,200 lbs. tensile strength
80HK, 22,046 lbs. tensile strength
7/8" dia. on Idlers; 1-3/16" diameter on Track Sprockets
Dual 8" diameter disk type
750 CCA
2,100 lbs. with no attachments
Industrial grade coiled steel springs (4)
5.36 sq. ft.
Contractor grade, Rotatable, height settings with Pin Included
Optional, 1 3/8" dia., 6 splined, 540 RPM, approx. 25 hp

	<b>Dimensions</b>							
	<b>A</b>	<b>B</b>	<b>C</b>	<b>D</b>	<b>E</b>	<b>F</b>	<b>G</b>	<b>H</b>
	<b>4900</b>	55-7/8"	62-1/2"	44-1/2"	14-1/4"	48-7/8"	9-1/2"	6"
<b>8000</b>	55-7/8"	62-1/2"	52"	14-1/4"	48-7/8"	9-1/2"	6"	18"

The Struck Corporation has a policy of continuous product improvement and reserves the right to change its products, specifications and dimensions at any time without notice or obligation. All dimensions and specifications are based upon best possible performance using the highest performance components available and running at 100% efficiency. Results will vary due to changes in size of engine and components, component wear, oil temperature, etc. If a particular specification or dimension is critical to your application contact the factory for more detailed information. Prices do not include transportation charges or any state or local taxes. 1% Cash discount offered when paying by cashier's check, money order or wire transfer.

**IMPORTANT: Though the MAGNATRAC 4900, and 8000 are offered completely assembled, it's still the customer's responsibility to provide competent service ability! The servicing can be provided either by the mechanically inclined customer, or by a local mechanic. Loaders, 6-Way Blade, backhoes, rear hitch with PTO and roll-over protective structures (ROPS) are shipped assembled. Some attachments may be on extra pallets. Other attachments and accessories are shipped in an easy-to-assemble "semi-kit" form for lowest cost shipping. We provide manuals & illustrations for complete service and repair so that anyone with reasonable mechanical skill can perform all required service work. Check the MAGNATRAC Specifications & Ratings (above) for a list of all standard features.**





# Front Mounted Attachments

## SWB54 Six-Way Blade - Assembled.

Extra heavy-duty, fully reinforced 54" wide x 22" high x 1/4" thick solid steel 6 way blade with 3/4" thick x 4" wide heat-treated "plow steel" cutting edge. Mounts directly to lower track frame for superior support. Complete with lift, tilt, and angle cylinders, hoses, fittings, mounting hardware. Features an extra heavy-duty front hitch system with total control of : lift, float, down-pressure, 25° left & 25° right angling and 9° of tilt above and 9° below horizon. Must completely remove the HL900 Loader to use. Works best when used together with the RH65 Three Point Hitch or no other rear attachment. **(Use MDB154 or MDB154S Angling Blade Kits for "dozing" in Loader applications.** Blade fully assembled on unit, unless HL900 is purchased as well. Your choice of which attachment gets mounted to the unit: SWB54 Blade or HL900 Loader.

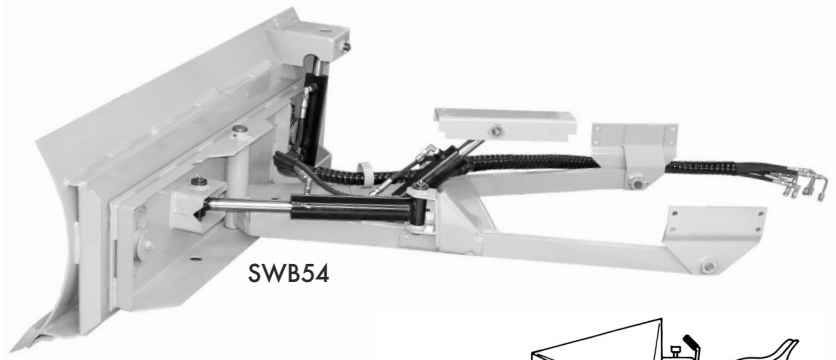

SWB54

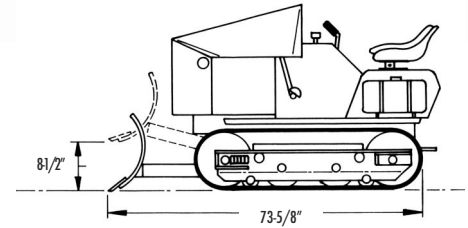

SWB54 Six-way Blade Kit . . . . . 525 lbs.

## SWBB Blade Extension & Weight Box - Assembled.

Blade extension increases blade height capacity by 9"; perfect for dozing bark chips, grain, snow, etc. Weight Box and included steel "ballast" increases Blade's down pressure by 221 lbs. A must if using the SWB54 Six Way Blade with a D1065 or D108 Backhoe. **Factory recommends using the SWB54 Six Way Blade with the RH65 Three Point Hitch or no other rear attachment for best results.**

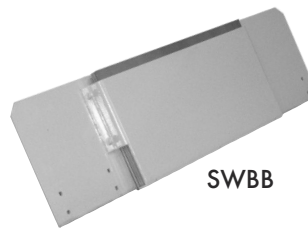

SWBB

SIX-WAY BLADE SPEC'S	
BLADE WIDTH	54"
TILT ANGLE (above/below horizon)	9°
BLADE ANGLE (left/right)	25°
LIFT (above/below grade)	8-1/2"/4"
LIFT FORCE (at cutting edge)	255 lbs

SWBB Blade Extension / Weight Box Kit . . . . . 221 lbs.

## HL900 Loader - Assembled.

93" Lift, 2300 lbs bucket breakout, 800 lbs maximum lifting capacity at full height. All-hydraulic bucket curl/dump, lift, float and down pressure functions. Lift cylinder safety lock included to hold loader arms up for maintenance. Bucket **not** included; choose from selection (see page 5). FB150 Ballast Box loaded with RW150 Ballast kit if Loader is used without D1065 or D108 Backhoes mounted to Magna-trac. Loader fully assembled on unit, unless SWB54 is purchased as well. If you purchase both: Your choice of which attachment gets mounted to the unit: SWB54 6-Way Blade or HL900 Loader. **(Add L5 Leveling Gauge Kit (below) for operator bucket leveling system on HL900).**

HL900 Loader Kit. . . . . 570 lbs.

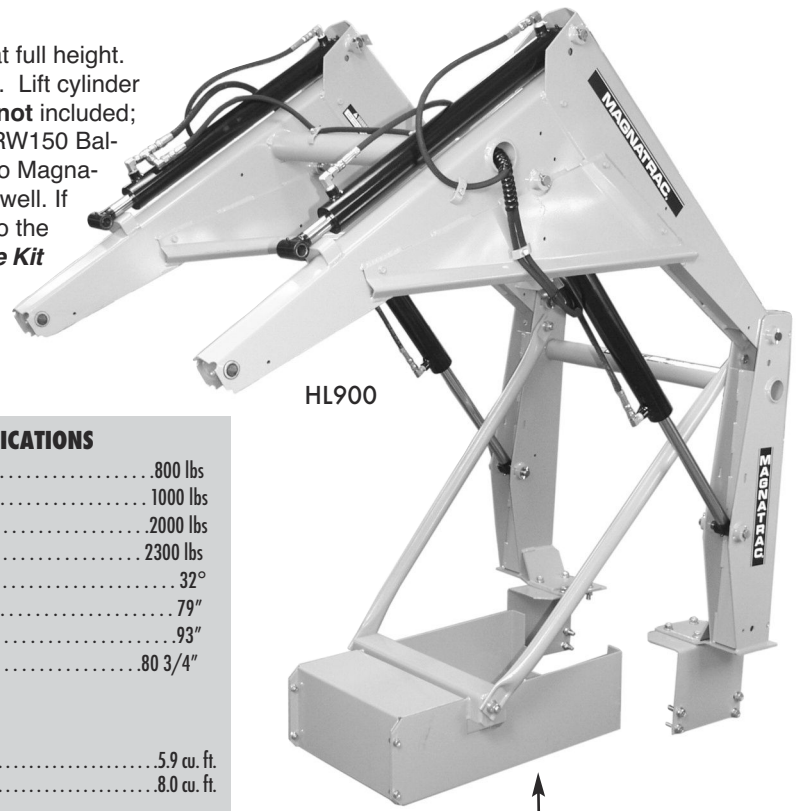

HL900

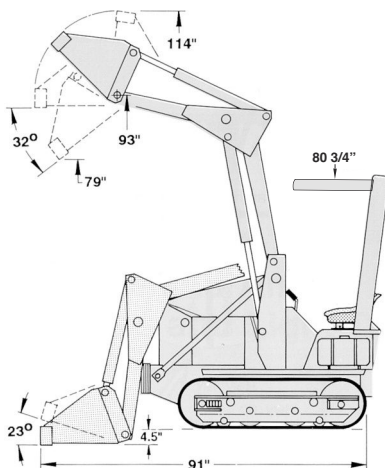

LOADER SPECIFICATIONS	
OPERATING CAPACITY	800 lbs
TIPPING LOAD	1000 lbs
BREAKOUT - LIFT	2000 lbs
BREAKOUT - BUCKET	2300 lbs
DUMP ANGLE	32°
DUMP HEIGHT	79"
LIFT HEIGHT	93"
ROPS HEIGHT (with track shoe)	80 3/4"
<b>Bucket Capacity (heaped)</b>	
EB460	5.9 cu. ft.
SB480S, SB480TS	8.0 cu. ft.

## L5 Leveling Gauge - Assembled.

Shows bucket level. Mounts to loader & bucket. **Customer marks with paint or tape for optimal position.**



L5 Leveling Gauge Kit . . . . . 1 lb.

**Note:** Shown with weight box that comes with D108 Backhoe. Ballast weight not included. (See FW20 Ballast Kit). Standard loader support brace included with loader if D108 backhoe not purchased. (Not shown).



# HL900 Loader Attachments

## Standard Pin Mount

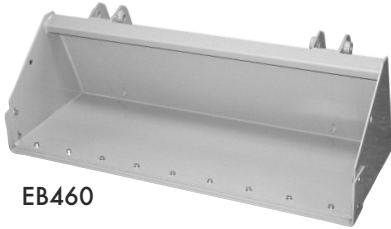

EB460

### EB460 Excavating Bucket Kit

48" wide x 15" high x 19" deep excavating bucket. Attaches with four Pins. Has bolt-on replaceable cutting edge. For tougher work add T10 Tooth Bar (see right).

EB460 Excavating Bucket Kit . . . 135 lbs.

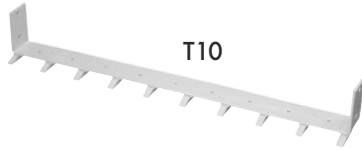

T10

### T10 Tooth Bar Kit

Bolt-on replaceable bar with 10 hardened "plow steel" teeth. Gives EB460 Excavating Bucket (see left) greater digging ability.

T10 Tooth Bar Kit . . . . . 15 lbs.



MDB154

### MDB154 Angling Blade Kit

Mounts to Loader in place of Bucket with 4 pins. Loader's hydraulics control blade's lift. Adjust 3 position blade's angle with single pin - no tools!. **[Add CK29 Cylinder Kit (below) for hydraulic angling]**. Blade is 54" wide, 17" high and 3/16" thick.

MDB154 Angle Blade Kit . . . . . 230 lbs.

### CK29 Cylinder Kit



CK29

CK29 Cylinder Kit . . . . . 20 lbs.

## Speed Hitch Mount

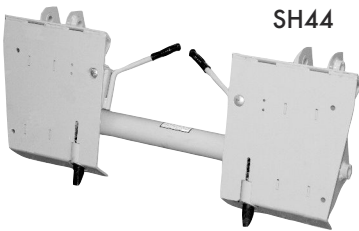

SH44

### SH44 Speed Hitch Kit

Universal Mounting Hitch allows HL900 Loader to quickly change out attachments below and **utilize third party skid steer attachments including augers, tillers, trenchers, snow blowers, grapples, pallet forks, and many more!** Check with attachment manufacturer for requirements.

SH44 Speed Hitch Kit . . . . . 105 lbs.



SB480S

### SB480S Material Bucket Kit

Heavy-Duty 48" wide x 19" high x 21" deep excavating bucket for use with SH44 Speed Hitch on HL900 Loader. Has beveled, heat-treated, "plow steel" cutting edge welded to bucket forward edge. **[SH44 only]**

SB480S Bucket . . . . . 170 lbs.

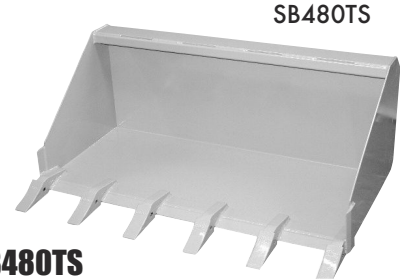

SB480TS

### SB480TS Excavating Bucket Kit

Heavy-Duty 48" wide x 19" high x 21" deep excavating bucket with six professional-quality replaceable teeth made of special "abrasive resistant" cast steel. Tooth adapter welded to bucket edge. **[SH44 only]**

SB480TS Bucket . . . . . 200 lbs.

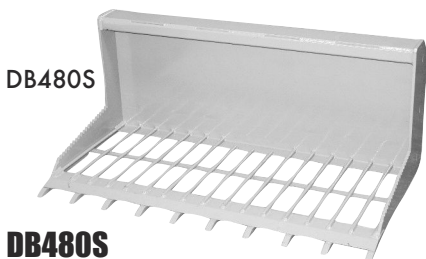

DB480S

### DB480S Debris Bucket Kit

Heavy-duty 48" wide x 19" high x 21" deep stone and debris bucket. 1/2" thick steel sidewalls cut to form teeth that grip logs & brush. 1/2" steel rod bottom allows dirt and debris to fall through. **[SH44 only]**

DB480S Bucket . . . . . 200 lbs.



BG48 Grapple Kit

BG48

Mounts to **[DB480S, SB480TS, & SB480S]** Buckets. Consists of four solid steel tines robotically welded to heavy-duty frame developing over 1,000 lbs of clamping force. Retracts completely to allow normal loader operations without removal.

BG48 Grapple Kit . . . . . 145 lbs.

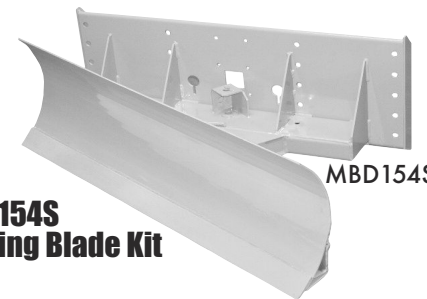

MDB154S

### MDB154S Angling Blade Kit

Uses Loader's hydraulics to control blade's lift. Adjust 3 position blade angle with single pin - no tools required. **[Add CK29 Cylinder Kit (above) for hydraulic angling]** Blade is 54" wide, 17" high and 3/16" thick. **[SH44 only]**

MDB154S Angle Blade Kit . . . . . 250 lbs.

# Rear Mounted Attachments

## D108 Backhoe - Assembled.

Backhoe with 8 ft. digging depth, 164° swing arc. Complete with cylinders, hoses, fittings, and six section hydraulic valve. Mounts to the rear of the unit and connects w/ 2 hoses and a few bolts. Does **not** include "Wobble Controls", Bucket or Accessories below. (See WC10 Wobble Controls [below], B808, B816, & B824 Buckets, Log Fork, Ripper [below]. Backhoe fully assembled, but on secondary pallet, unless a factory pick-up.

HL900 Loader (loaded with FW20 Ballast Kit) or equivalent counterweight must be mounted to front of Magnatrac for proper balance.

**D108 Backhoe Kit** . . . . . 865 lbs.  
**FW20 Ballast Kit** . . . . . 625 lbs.

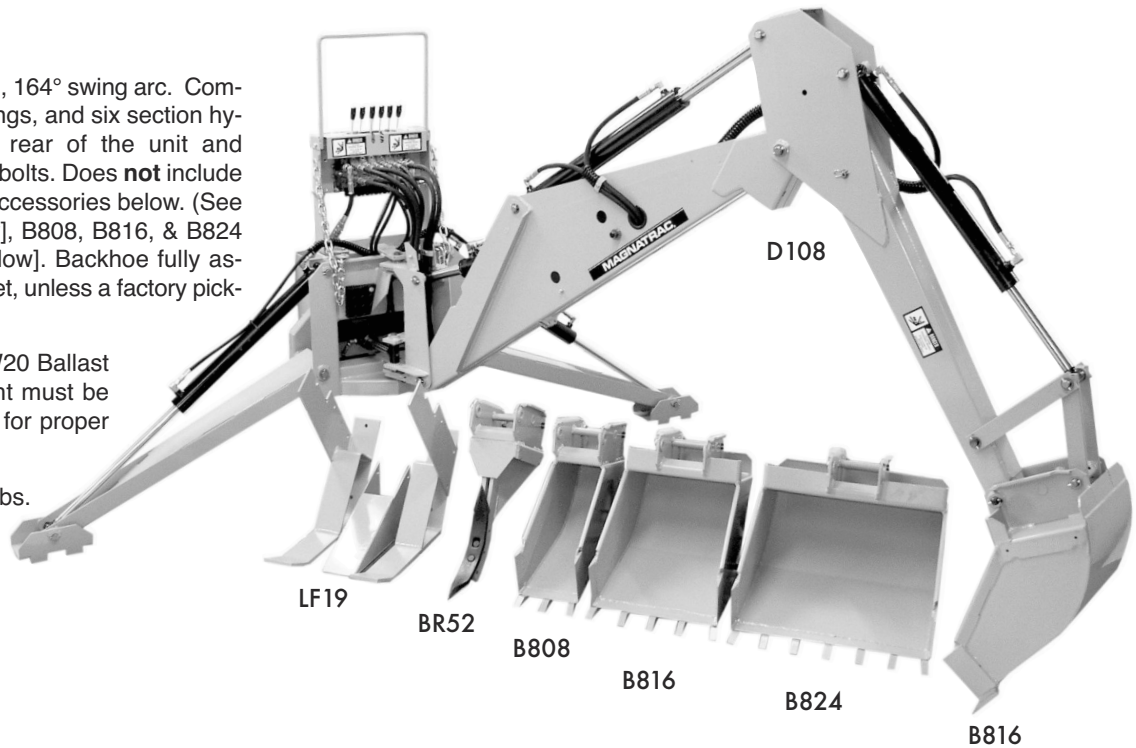

## D108 Backhoe Buckets & Accessory Kits

**WC10 Wobble Controls Kit** - Easy to use joystick control. Operator controls all four digging operations with only two control handles. . **(Factory Option Only)**

- B808 8" Bucket Kit** - Eight inch digging width . . . . . 55 lbs.
- B816 16" Bucket Kit** - Sixteen inch digging width (Most common size).. . . . . 75 lbs.
- B824 24" Bucket Kit** - Twenty-four inch digging width . . . . . 95 lbs.
- LF19 Log Fork Kit** - Two "forks" that bolt to interior of B816 or B824 Buckets (above) and an adjustable "thumb" mounted to the Backhoe's dipper. [Requires drilling ten 1/2" holes in Bucket.] . . . . . 85 lbs.
- BR52 Frost / Chisel Tooth Ripper Kit** - Heavy-duty single tooth ripper with two replaceable teeth: (1) 16" x 2" x 1/2" thick "plow steel" tooth for stone & frost picking & hardpan penetration to 18"; the other 15" x 2" x 1/2" thick tooth, allows root cutting to depths of 18". Mounts in place of Bucket on Backhoe Dipper. . . . . 35 lbs.

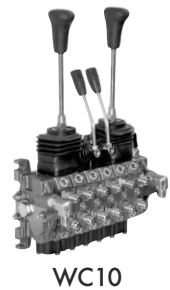

## FB150 Ballast Box Kit

Required rear weight box for counter balance when using HL900 Loader without a backhoe or without a RH65 with any 750 lb. rear tractor attachment. Comes with both rigid tractor mount (shown at right) and with special RH65 three point hitch mount as well. FB150 Ballast Box not required if HL900 Loader and D1065 or D108 Backhoe are mounted simultaneously.

Does **not** include steel ballast - order RW150 or purchase counter weight locally.

**FB150 Ballast Box Kit** . . . . . 102 lbs.  
**RW150 Ballast Kit** . . . . . 750 lbs.

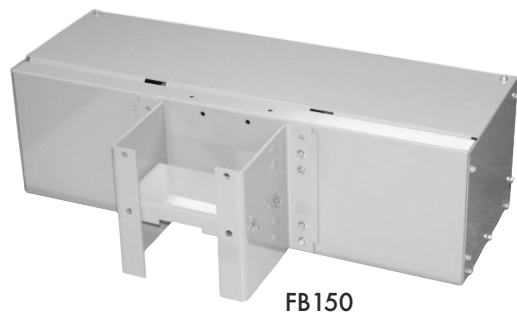



# Rear Mounted Attachments

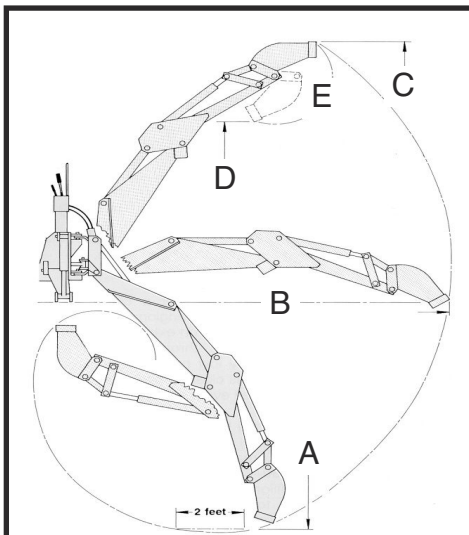

### BACKHOE DIMENSIONS

	A	B	C	D	E
<b>D1065</b>	80"	114"	103"	75"	162"
<b>D108</b>	99"	140"	118"	85"	200"

### BACKHOE RATINGS

	<b>D1065</b>	<b>D108</b>
<b>BUCKET FORCE</b>	2500 lbs	3200 lbs
<b>DIPPER FORCE</b>	1250 lbs	2250 lbs
<b>LIFT (@ bucket pivot)</b>	135 lbs	250 lbs
<b>LIFT (@ dipper pivot)</b>	210 lbs	400 lbs
<b>SWING ARC</b>	120°	164°
<b>STABILIZER SPREAD</b>	41-1/2"	119"
<b>TRANSPORT WIDTH</b>	41-1/2"	48-1/2"
<b>BUCKET CAPACITIES</b>		
B808	-	0.67 cu. ft.
B612	1.16 cu. ft.	-
B816	-	1.54 cu. ft.
B824	-	2.51 cu. ft.

### D1065 Backhoe - Assembled.

Backhoe with 6 1/2 ft. digging depth, 120° swing arc. Complete with cylinders, hoses, fittings, and six section hydraulic valve. Does **not** include "Wobble Controls" or Bucket (see WC10 Wobble Controls & B612, B616 Buckets below). Backhoe fully assembled, but on secondary pallet, unless a factory pick-up.

HL900 Loader, SWB54 Six-Way Blade (with SWBB Blade Extension & Weight Box), or equivalent counterweight must be mounted to front of Magnatrac for proper balance.

**D1065 Backhoe Kit** ..... 455 lbs.

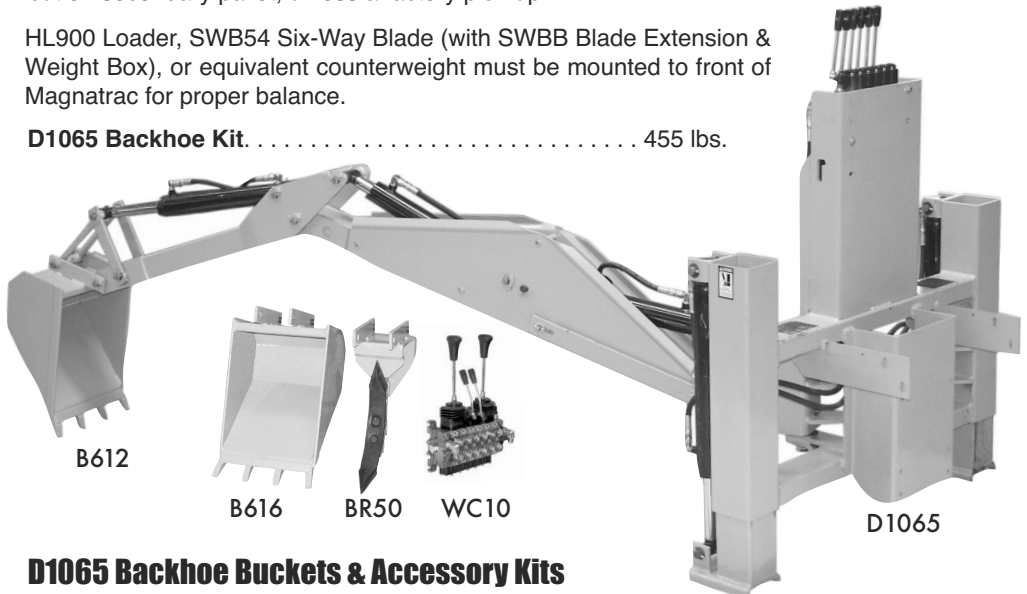

### D1065 Backhoe Buckets & Accessory Kits

**WC10 Wobble Controls Kit** - Allows operator to control all four digging operations with only two control handles. (**FACTORY OPTION ONLY**)

**B612 12" Bucket Kit** - Twelve inch digging width ..... 30 lbs.

**B616 16" Bucket Kit** - Sixteen inch digging width ..... 43 lbs.

**BR50 Frost / Chisel Tooth Ripper Kit** - Heavy-duty single tooth ripper with two replaceable teeth: (1) 16" x 2" x 1/2" thick "plow steel" tooth for stone & frost picking & hardpan penetration to 18"; the other 15" x 2" x 1/2" thick serrated edge tooth allows root cutting to depths of 18". Mounts in place of Bucket on Backhoe. .... 25 lbs.

**RT24 Rock/Debris Thumb Kit** [not shown] ..... 35 lbs.

### RH65 Rear Hitch - Assembled.

Full sized, all-hydraulic, Category #1 three point Rear Hitch providing "lift, float, and down pressure" to both lift arms. Check with factory for proper front counterweighting. Does **not** include PTO70 Power Takeoff (see below). Includes cylinder safety lock to hold hitch "up" when disconnecting hydraulic source. Develops 1000 lbs. Lift. (Requires HL900 Loader or SWB54 for proper balance) Hitch fully assembled, but on secondary pallet.

**RH65 Rear Hitch Kit** ..... 240 lbs.

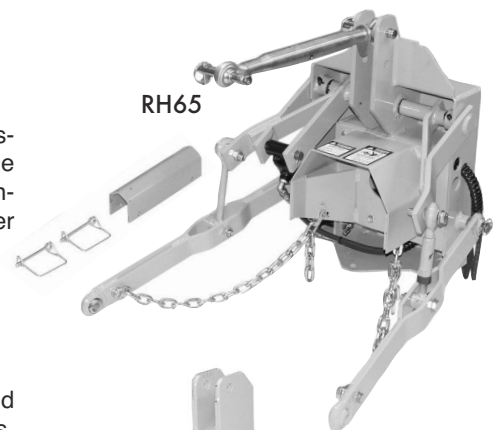

PTO70

### PTO70 Power Takeoff - Assembled.

Full power hydraulic motor with standard 1-3/8" diameter, six splined shaft. Mounts in "cavity" in RH65 REAR HITCH. Complete with hoses, fittings and all mounting hardware. See model spec area for PTO hp output. PTO fully assembled, mounted to RH65.

**PTO70 Power Takeoff Kit** ..... 24 lbs.

### S14 Scarifier / Ripper Kit

Heavy-duty five tooth Scarifier / Ripper. Five scarifier teeth are interchangeable on heavy-duty mounting frame to create a variety of ripping patterns. Useful for shattering hard, dry soil, compacted driveways, etc.

**S14 Scarifier / Ripper Kit** ..... 115 lbs.

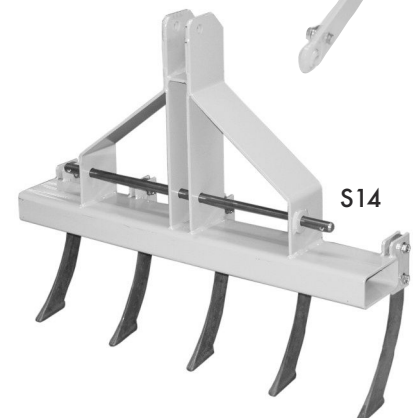

# Front & Rear Mounted Attachments

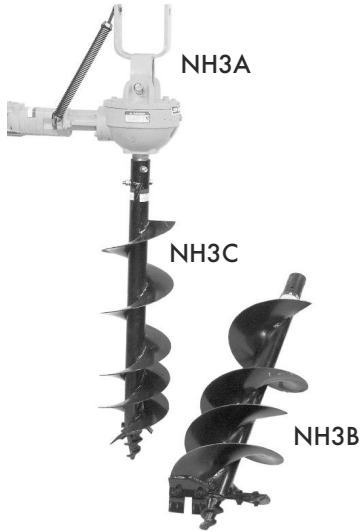

## NH3A Remote Auger Kit

Complete hydraulic auger drive assembly which can be mounted to your Loader Bucket or in place of your D108 Backhoe Bucket. **Does not require a Rear Hitch or Power Takeoff...** Loader and Backhoe can remain in place. Does not include Auger (see below). **Requires HL900 Loader or D108 Backhoe & HC74 Hydraulic Circuit.**

NH3A Remote Auger Kit ..... 160 lbs.

## Augers for NH3A Remote Auger

NH3B Auger - 12" dia. cut, alloy steel point and cutting edge, 42" length ..... 50 lbs.

NH3C Auger - Same as NH3B (left), but with 9" dia. cut, 42" length ..... 37 lbs.

NH3D Auger - 24" auger, perfect for planting small trees, 30" length (not shown) ..... 75 lbs.

# 3rd Party Attachments

## Skid Steer, Category 1 Three Point Hitch and Tractor Attachments

Many companies make 3rd party attachments that will fit our SH44 Speed Hitch & RH65 Category 1 Three Point Rear Hitch. Most are sold through farm implement places like: Tractor Supply, Dealerships or Websites. The flow rates and requirements vary depending on each attachment. Please speak with a Struck Sales Person to verify specific ratings needed to operate your attachment.

- Snow Blowers
- Pallet Forks
- Grapples
- Brush Mowers
- Breakers
- Stump Grinders
- Chippers
- Trenchers
- Sweepers
- Concrete Mixers
- Earth Augers
- Snow Blades
- Log Winches
- Spreaders
- Tillers
- Tree Spades
- Soil Levelers
- Angle Brooms
- Grapple Rakes
- and many more!



# What's the Next Step?

## I Have a Few Questions

So you have read everything, combed the web for every piece of information you could find, watched our videos so many times you have it memorized, spoken with a MAGNATRAC® owner, and you still have questions, give us a call today! No worries, no high pressure sales here...just honest answers to your questions.

**Call or Email Us Today!**

Toll Free: 1.877.828.8323

Email: sales@struckcorp.com

## I'd Like a FREE Quote

If you've decided which MAGNATRAC® and attachments you need, then all you need now is a **FREE no-obligation quote!** This way we double check everything for compatibility and optimum performance. We'll also do a little research and find the best shipping rates for your location.

We offer many shipping options to fit your needs and budget!

- Local Freight Terminals
- Local Businesses
- Home Delivery
- and More!

## I'm Ready to Buy

Give us a call or email us and we'll make sure to get your MAGNATRAC® order into our production schedule without delay! From deposit until shipment, your order usually ships within 4 weeks.

We accept many payment options: debit and credit cards, cashier's checks, money orders, wire transfers or PayPal are the most common. If you're looking for financing, ask us about our short term PayPal Financing or check with your local bank or credit union for additional longer term financing options.



**Struck Corp.**  
PO Box 307  
Cedarburg, WI 53012



**(877) 828-8323 phone**  
**(262) 377-9247 fax**  
**sales@StruckCorp.com**

