

# MAGNATRAC®

## RS1000



## Operator / Technical Manual

C. F STRUCK CORPORATION - CEDARBURG, WISCONSIN 53012

# Very Important Facts

The following are random facts that will be expanded on within this Manual. They are brought to you “first” to impress upon you their primary importance in preventing damage to your RS1000 and also to protect your safety and prevent costly and unnecessary maintenance expenses.

## SAFE BLOCKING DIAGRAM

When “blocking” your Crawler off the ground for service, be aware that you should not apply a “pointed force”, like the end of a hydraulic jack, in the area marked as “unsupported” (below)!

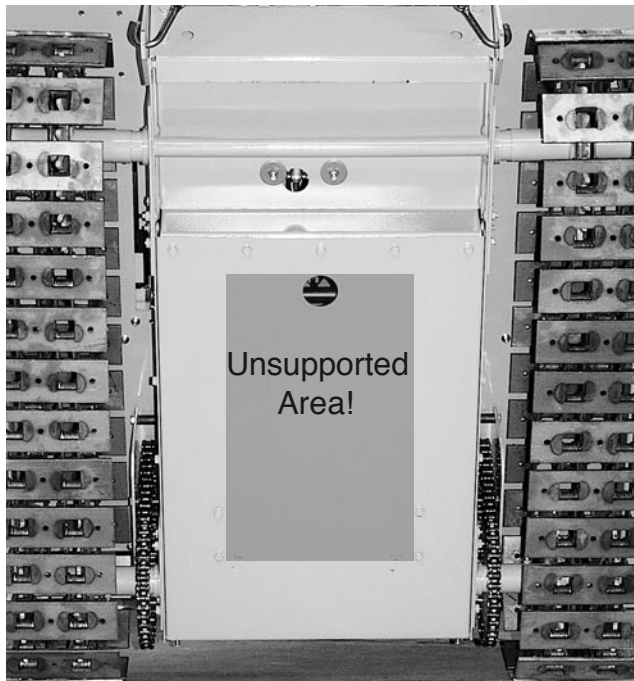

## TRACKS

Avoid climbing a pile of loose material and counter-rotating your Tracks (“cork-screwing”). This action forces unnecessary amounts of material into your Tracks and can cause derailing of Tracks.

## TRACK CLUTCHES

Do not “jam-on” your clutch controls as this prematurely wears them. Operate the clutches smoothly and work into your load.

## ENGINE TORQUE

The greatest amount of power (drawbar torque) your Crawler can deliver is near the Engine’s mid-speed range. To go faster, your Engine’s “drawbar torque” will be diminished by having to go faster.

Doing all your heavy work at mid-speed does three things: It keeps the Engine cooler working at a slower speed, gives you maximum drawbar torque, and at the same time does it at a speed that provides time to make “attachment adjustments” on the go!

You’re encouraged to completely read this Manual to get a firm over-view of: how your Crawler operates, significant safety points, and also maintenance tips on how to increase your Crawler’s life.

## PARKING BRAKE

**NEVER FORGET** to disengage your Parking Brake...

**BEFORE** you drive away. If you fail to disengage the Parking Brake, it will wear very rapidly and be of no value in an emergency!

## LUBRICATION OF POWER SHAFT ENDS

Read and understand the “Special Note” in the “Belt Installation” section of this manual. By following it’s simple lubrication instructions you can save yourself a lot of work, and potential expense in the future and make Belt changing much easier.

# TO THE OPERATOR

## *Congratulations...*

on your purchase of a quality-built, American made compact Crawler. We are confident that the dependability and economical performance of your Struck Crawler will prove that you made a wise choice.

The purpose of this Manual is to acquaint you with the RS1000 Magnatrac Crawler. This Manual explains how to operate and service your Crawler, and how to maintain its high operating efficiency. Instructions are given clearly, with the intention of making these operations as easy as possible.

Keep this Manual in a convenient place for quick and easy reference. Use it as a guide whenever questions arise. You have purchased a dependable, sturdy Crawler, but only by operating and caring for it properly can you expect to receive the service and long life for which it was designed.

If in the future you need new parts to replace those that may be worn, insist on genuine Struck parts. They are exact duplicates of the originals, made from the same patterns and of the same high-quality materials.

When ordering parts, always be sure to give the following information for your Crawler:

**Model Number:**

**Serial Number:**

**Engine Model Number:**

**Engine Serial Number:**

**C. F. STRUCK CORPORATION**  
W51-N545 STRUCK LANE  
CEDARBURG, WISCONSIN 53012  
Phone: (262) 377-3300  
Fax: (262) 377-9247

## RECOGNIZE SAFETY INFORMATION



This is the safety-alert symbol. When you see this symbol on your Crawler or in this Manual, be alert to the potential for personal injury.

## UNDERSTAND SIGNAL WORDS

A signal word — DANGER, WARNING, or CAUTION — is used with the safety-alert symbol. DANGER identifies the most serious hazards.

Safety labels with the signal word DANGER or WARNING are typically near specific hazards.

General precautions are listed on CAUTION safety labels. CAUTION also calls attention to safety messages in this Manual.

## FOLLOW SAFETY INSTRUCTIONS

Carefully read all safety messages in this Manual and on your Crawler and Attachment safety labels. Follow recommended precautions and safe operating practices.

Keep safety labels in good condition. Replace missing or damaged safety labels.

To keep your Crawler running efficiently, read the instructions in this Manual.

Left side, right side, front, and rear are viewed by facing in the direction of the Crawler's forward travel.

Record your Crawler serial numbers in the space provided. You need this information when you order parts.

# SAFETY RULES



Reports on accidents show that careless use of machinery causes a high percentage of accidents. You can avoid many accidents by following the safety rules on these pages. Study these rules carefully and enforce them on the job

## SAFETY BEFORE STARTING OR OPERATION

The Crawler should be operated only by persons approved to do so.

Clothing worn by the operator should be fairly tight and belted.

Fasten a first aid kit to the Crawler.

Fasten a fire extinguisher to the Crawler. Keep the extinguisher fully charged. Learn to use it correctly.

If the Crawler has an unsafe condition, do not operate. Put a tag on the Track Drive Controls.

Do not start or operate the Crawler unless you are in the operator's seat.

Before you start the Engine, be sure there is plenty of ventilation.

Keep hands, feet, and clothing away from power-driven parts.

Fasten a slow-moving vehicle sign to the rear of the Crawler.

Guards, shields, and other protective devices must be in place and in good condition.

Before you start or operate the Crawler, clear the area of all persons and obstacles.

## OPERATION SAFETY

When you operate the Crawler, do not allow anyone to ride on the Crawler or its equipment.

Drive at safe speeds at all times, especially on rough ground and hillsides.

Carry the Bucket or Blade as low as possible at all times, especially when you work on a hillside or back up a steep hill.

Do not drive too close to the edge of a ditch or excavation.

Watch for overhead wires. Do not touch wires with any part of the Crawler or its Attachments.

Do not leave your Crawler unattended with the Engine running.

Keep work areas as level as possible.

When loading logs with the Log Forks, make sure the logs are balanced.

When you drive out of a ditch or excavation, or up a steep hillside, or when Crawler is hitched to a heavy load, engage Track Drive Controls slowly. If the front of the Crawler comes off the ground, release Track Controls immediately.

Do not use the Crawler as a battering ram.

Do not guide cable onto Winch Drum with your hands.

When you drive the Crawler on a road, use the correct lights to warn operators of other vehicles.

Before you move any equipment, be sure all persons are away from the Crawler.

When the Crawler is operating, only the operator should be on it.

If it is necessary to make checks with the Engine running, always use two people...the operator at the controls should be able to see the person doing the checking

## KEEP HANDS AWAY FROM MOVING PARTS!

## BEFORE YOU DISMOUNT:

**Move Track Drive Controls to neutral.**  
**Engage Parking Brake Lever**  
**Lower all equipment to the ground.**  
**Stop Engine and remove the key.**

## **SERVICE SAFETY**

Be sure you understand a service procedure before you work on the Crawler.

Unauthorized modifications to the Crawler may impair the function and/or safety and affect Crawler life.

Do not work under Crawler or raised equipment unless it is correctly supported...contact factory for recommended procedures.

Before you work on the Engine or electrical system, disconnect the battery's "ground" ( - ) terminal first! When work is finished, connect battery's "ground" terminal ( - ) last.

When driving connecting pins (Spring Pins), wear goggles or safety glasses.

Do not run Engine while working on the Crawler.

Be careful when handling any type of fuel. Do not smoke while filling the fuel tank or working on the fuel system.

Check for faulty wiring or loose connections.

Do not lubricate or work on the Crawler while it is moving.

When you work near the Track Springs, use extreme care. Do not disassemble parts unless you know the correct procedure and have correct tools.

## **FIRE PREVENTION MAINTENANCE**

Be prepared if an accident or fire should occur.

Know where the first aid kit and the fire extinguisher are located...know how to use them.

Check fire extinguisher for correct charge.

Do not smoke while refueling or handling highly flammable material.

Shut off the Engine when refueling.

Use care in refueling if the Engine is hot. Do not use open pans of gasoline or diesel fuel for

cleaning parts. Use good commercial, nonflammable solvents.

Provide adequate ventilation when charging battery.

Do not check battery charge by placing metal objects across the posts.

Do not allow sparks or an open flame near battery.

Do not smoke near battery.

Never check fuel, battery electrolyte, or coolant levels with an open flame.

Never use an open flame to look for leaks anywhere on the equipment.

Never use an open flame as light anywhere on or around the equipment.

When preparing Engine for storage, remember that inhibitor is volatile and therefore dangerous.

Seal and tape openings after adding the inhibitor.

Keep container tightly closed when not in use. Inspect electrical wiring for worn or frayed insulation. Install new wiring if wires are damaged.

Temperature in Engine compartment may go up immediately after you stop the Engine. Be on guard for fires.

Before you clean trash from the Engine compartment, wait until the Engine has cooled. Open Hood to cool the Engine faster. While the Engine cools, clean trash from other areas.

Check for leaking fuel lines or fittings with a piece of cardboard or wood. Do not use your hands.

Tighten loose fittings. If hoses are kinked, install new parts.

## **NOISE PROTECTION**

Prolonged exposure to loud noise can cause impairment or loss of hearing. Wear a suitable hearing protective device such as earmuffs or earplugs to protect against objectionable or uncomfortably loud noise.

## **START ENGINE ONLY FROM THE OPERATOR'S SEAT!**

Avoid possible injury or death from Crawler runaway.

Do not start Engine by shorting across starter solenoid terminals. Crawler may start and move if normal circuitry is bypassed.



**CAUTION:** Never start Engine while standing on ground. Start Engine only from operator's seat, with Brake engaged.

Inspect your Crawler carefully each day before you start it. See "Pre-Start Inspection".

Clean your Crawler regularly.



## CONTROLS & INSTRUMENTS

Learn the location and purpose of all Controls, Instruments and Warning labels. Thoroughly study the Operator's Manual furnished by the engine manufacture and included with your Crawler instructions.

**A - LEFT TRACK  
CLUTCH CONTROL**

**B - RIGHT TRACK  
CLUTCH CONTROL**

**C - THROTTLE CONTROL**

**D - CHOKE CONTROL**

**E - HEADLIGHT SWITCH**

**F - KEY IGNITION SWITCH**

**G - CIRCUIT PROTECTOR**

**H - FUEL VALVE**

**I - PARKING BRAKE**

# A & B - LEFT & RIGHT TRACK CLUTCH CONTROLS

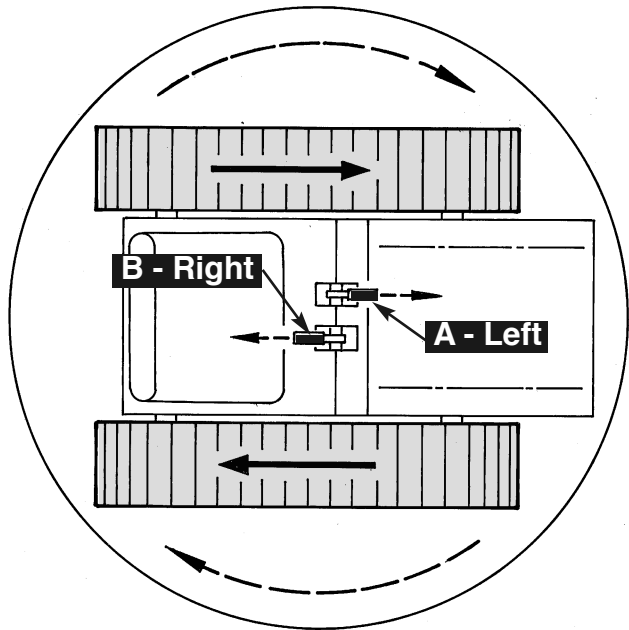

**INTRODUCTION:** The turn demonstrated (above) is the key to your Crawler's superior maneuverability. It is accomplished with only two controls, the **A & B** Left & Right Track Controls. The illustrations (below) show how to maneuver your crawler in other turns.



## MOVING FORWARD:

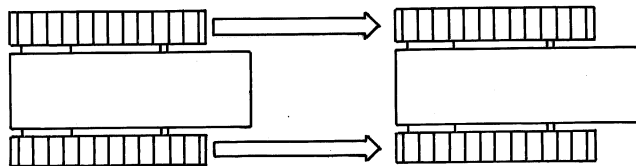

To move straight ahead, simultaneously push forward on both Left and Right Track Controls.

## MOVING REARWARD:

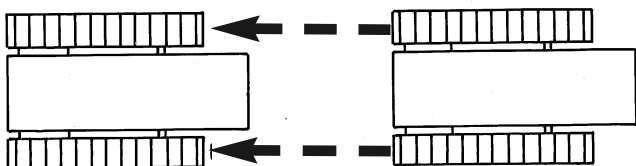

To move straight rearward, simultaneously pull rearward on both Left and Right Track Controls.

## TURNING RIGHT:

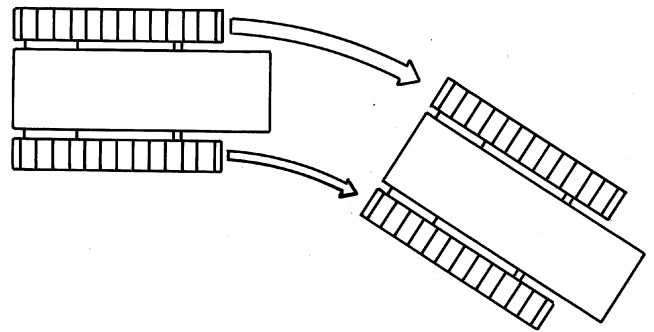

To turn sharply right, push forward on Left Track Control while holding Right Track Control in neutral.

## TURNING LEFT:

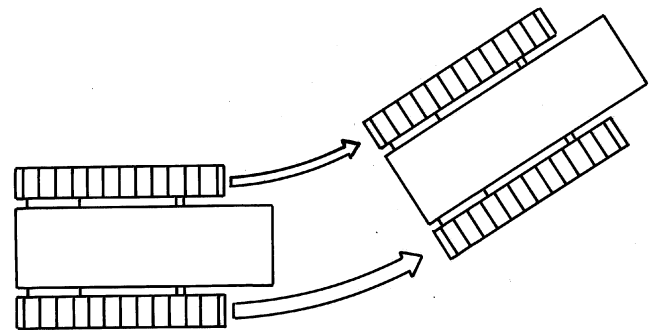

To turn sharply left, push forward on Right Track Control while holding Left Track Control in neutral.

## COUNTER-ROTATING TRACKS

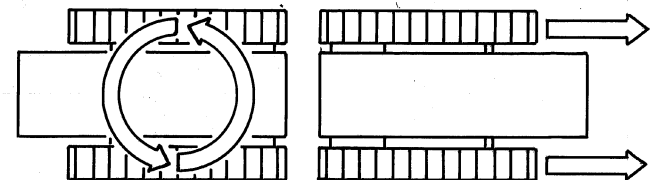

To counter-rotate Tracks (tightest turn possible), push one Track Control forward while simultaneously pulling rearward on the other Track Control.

**NOTE:** When either Track Control is "slowly" released, it will automatically return to neutral. NEVER allow Track Controls to "snap-back" to neutral. See OPERATION section of this manual for further instructions.



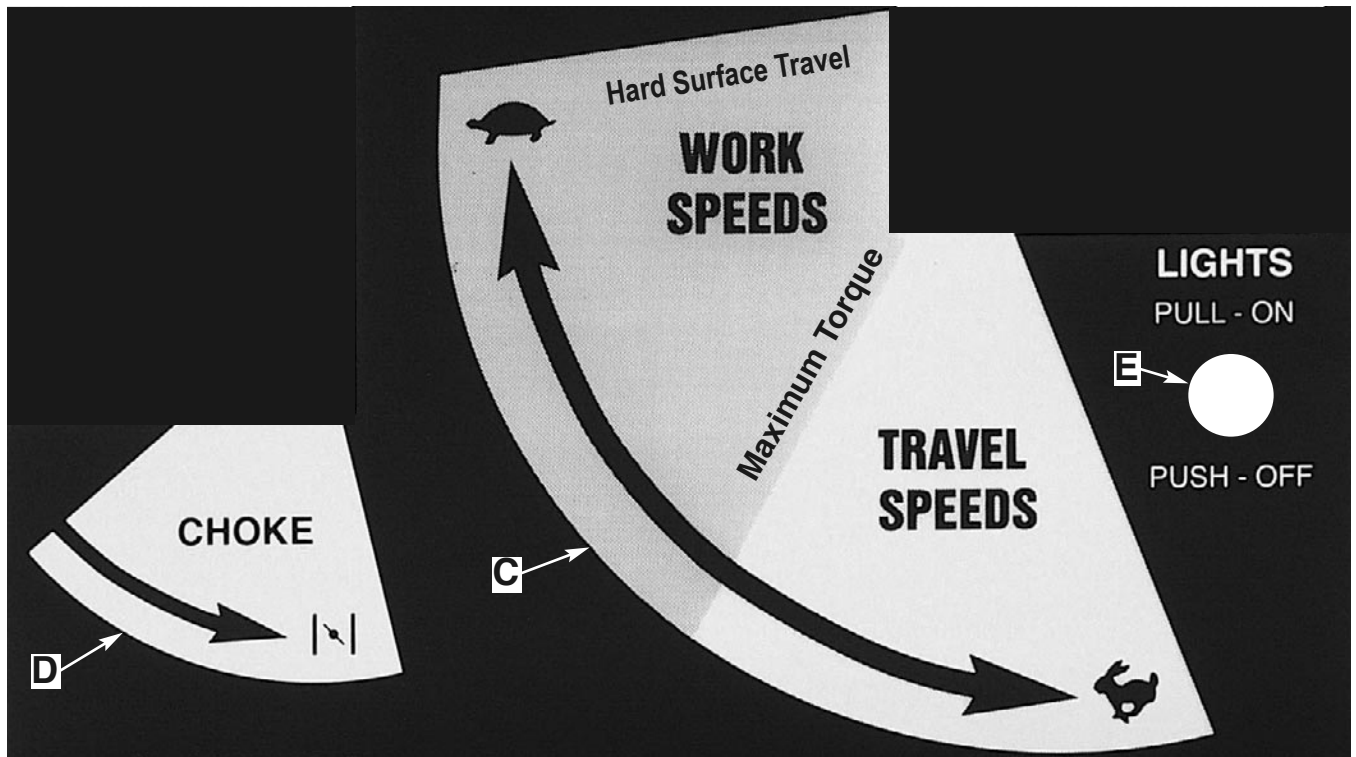

## DASHBOARD CONTROLS

### C - THROTTLE CONTROL

The Throttle is lever operated, rotating in a wide arc. This arc is divided into two speed ranges; the slower Work Speeds and the faster Travel Speeds. Your Crawler has maximum “pushing force” (maximum torque, according to the engine manufacturer) at the mid-range speed but with a declining level of torque as you increase your travel speed. We advise using only as much throttle as needed for a particular application. If the engine bogs down, please feel free to use more throttle when you feel it is needed.

Though all crawlers by their design are somewhat “rough riding”, you can minimize the “roughness” by traveling at the lowest speeds when going over hard surfaces.

### D - CHOKE

The Choke Control is lever operated. Rotate the lever counter-clockwise to increase engine choking; rotate clockwise to decrease engine choking. (Consult engine manual for more information).

### E - HEADLIGHT SWITCH

The Headlight Switch is a basic “Pull ON”, “Push OFF” switch. Behind the Switch is a replaceable Safety Fuse. When replacing, use a new fuse of the same amps as the one being replaced.

### F - KEY IGNITION SWITCH

Switch is activated by rotating key clockwise. Turning it fully clockwise will engage engine starter ...release key and it will return automatically to the RUN “ON” position. Turn fully counter-clockwise to OFF position to stop engine. Remove key.

### G - CIRCUIT PROTECTOR

The Circuit Protector protects the battery charging circuit. (Consult engine manual for more information).



### H - FUEL VALVE

The Fuel Valve Lever controls the fuel to the carburetor. Turn it OFF when cleaning sediment bowl on carburetor. (Consult Engine Manual for more information).

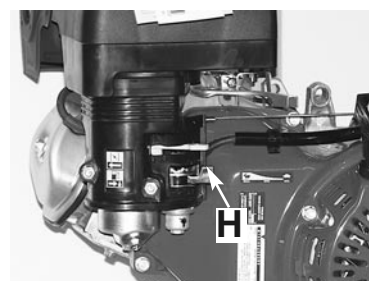

## I - PARKING BRAKE

The Parking Brake acts both as a parking brake and as an emergency brake.

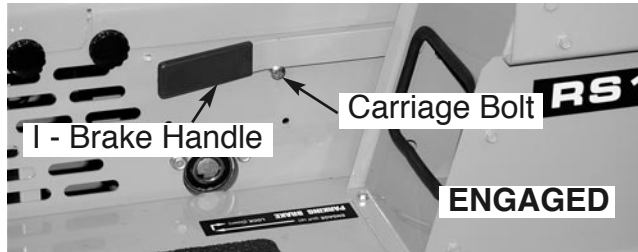

To “engage” Parking Brake, pull Brake Handle up firmly and loop it “up and over” the Carriage Bolt provided...make sure handle edge is on top of Bolt and behind “inside face” of Carriage Bolt.



To “disengage” Parking Brake, reverse the above procedure and allow Brake Handle to rest on Fender.

As the Parking Brake is also your emergency brake, it’s extremely important to maintain its performance with daily inspection. See Service section of this manual for proper procedures.

### EXTREMELY IMPORTANT:

As it’s mandatory to engage the Parking Brake **before** starting your crawler, always remember to disengage it **before** driving away.



**If you fail to disengage the Parking Brake it will wear very rapidly and be of no value in an emergency!!**

# OPERATION

## PRE-STARTING INSPECTION

Before you start your Crawler for the first time each day, perform the following checks:

### ENGINE COMPARTMENT

- Check oil level.
- Check air intake system.
- Remove trash and oil/dirt deposits.

### TRACKS, ATTACHMENTS, SHEET METAL

- Check for bent, broken, or missing parts.
- Check Track Springs.

### HARDWARE

- Check for loose or missing parts.

### ELECTRICAL SYSTEM

- Check for worn or frayed wires or loose connections.

### LUBRICATION

- Check lubrication points shown in Periodic Service section of this Manual.

### GUARDS AND SHIELDS

- Check for tightness and condition.

### BATTERY COMPARTMENT

- Remove trash.
- Check cables for tightness and corrosion.

### FUEL TANK

- Check fuel level.

### OPERATOR'S STATION

- Check control levers for free movement.
- Clean fenders and instrument panel.
- Adjust Seat location to fit operator.

## CAUTION - Before you start the engine:

Clear the work area of people and obstacles

Check the condition of the Crawler. (Prestart inspection).

Be sure there is enough ventilation.

Be sure to know the correct starting and stop ping procedure.

Sit in the Operator's Seat.

## PREPARE FOR ENGINE STARTING

1. Allow Left (**A**) and Right (**B**) Track Controls to assume their natural "spring-loaded" center neutral positions.

2. Engage Parking Brake (**I**). (Make sure Brake lever is pulled "up and over" round head of Carriage Bolt provided...make sure handle "edge" is on top of this Bolt and behind its inside face).

3 Check that all Attachments are in the fully lowered position.

4. Make sure you are properly seated so Seat Safety Switch will engage

## STARTING THE ENGINE

1a. **Cold Engine** - Place the Throttle Control (**C**) midway between the Slow and Fast positions. Place the Choke Control (**D**) into the On (fully choked) position.

1b. **Warm Engine** (normal operating temperatures) - Place the Throttle Control midway between the Slow and Fast positions. Place the Choke Control into the Off (no choke) position.

2. Activate the Key Ignition Switch (**F**) by rotating the key clockwise until starter engages. Release the key as soon as the Engine starts ...Switch will return to the Run "On" position.

**NOTE:** After starting a "cold" Engine, it may be necessary to leave the Choke partially On for a few minutes before moving it to the **Off** position



**CAUTION:** Do not crank the Engine continuously for more than 10 seconds at a time. If the Engine does not start, allow a 60-second cool-down period between starting attempts. Failure to follow these guidelines can burn out the starter motor.



**CAUTION:** If the Engine develops sufficient speed to disengage the starter but does not keep running (a “false start”), the Engine rotation must be allowed to come to a complete stop before attempting to restart the Engine.

If the starter is engaged while the flywheel is rotating, the starter pinion and flywheel ring gear may clash, resulting in damage to the starter.

If the starter does not turn the Engine over, shut off starter immediately. Do not make further attempts to start the Engine until the condition is corrected.

If the battery charge is not sufficient to turn over the Engine, recharge the battery.



**CAUTION:** Do not attempt to jump start the Engine with another battery. Starting with batteries larger than those recommended can burn out starter motor.

## WARM-UP PERIOD

Run Engine at half speed for 5 minutes.

Do not run Engine at fast, or slow idle.

Operate Crawler at less-than-normal loads and speeds for the first 15 minutes.



**WARNING:** Lethal Exhaust Gases!  
Engine exhaust gases contain poisonous carbon monoxide. Avoid inhaling fumes, and never run the Engine in a closed building or confined area.

**NOTE:** Assembled Crawlers are “run in” under no load at the factory to properly break-in their drive train.

## TRAVELING



Disengage Parking Brake (I); Fully raise all Attachments to recommended traveling heights.

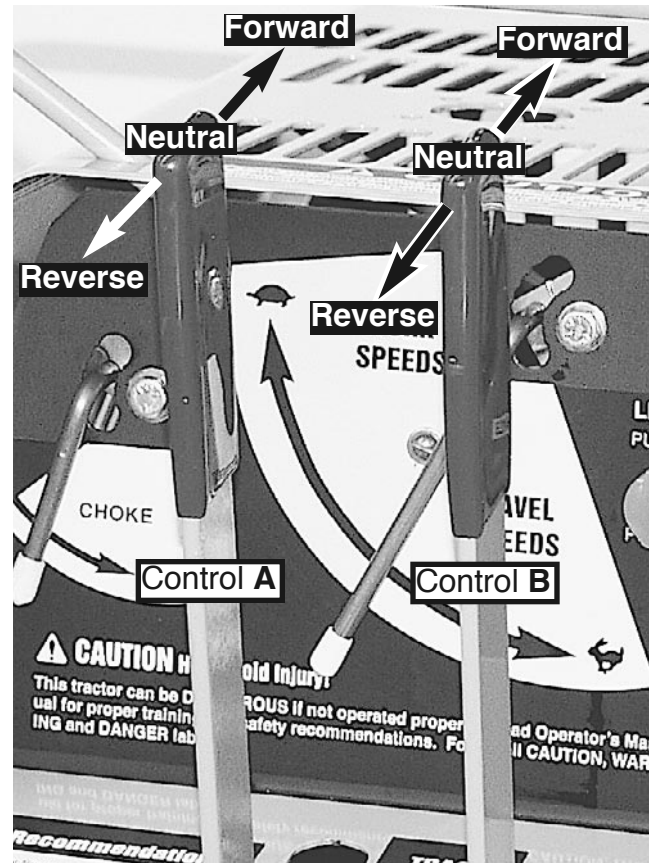

**To move *straight ahead***, simultaneously push both Left Track Control (A) and Right Track Control (B) forward.

**To move *straight to the rear***, simultaneously pull both Right and Left Track Controls rearward.

**To turn *sharply to the right***, push Left Track Control fully forward...leave Right Track Control in neutral.

**To turn *slowly to the right***, push Left Track Control fully forward while simultaneously pushing “partially” forward on Right Track Control...the farther you push the Right Track Control forward, the slower you will turn right.

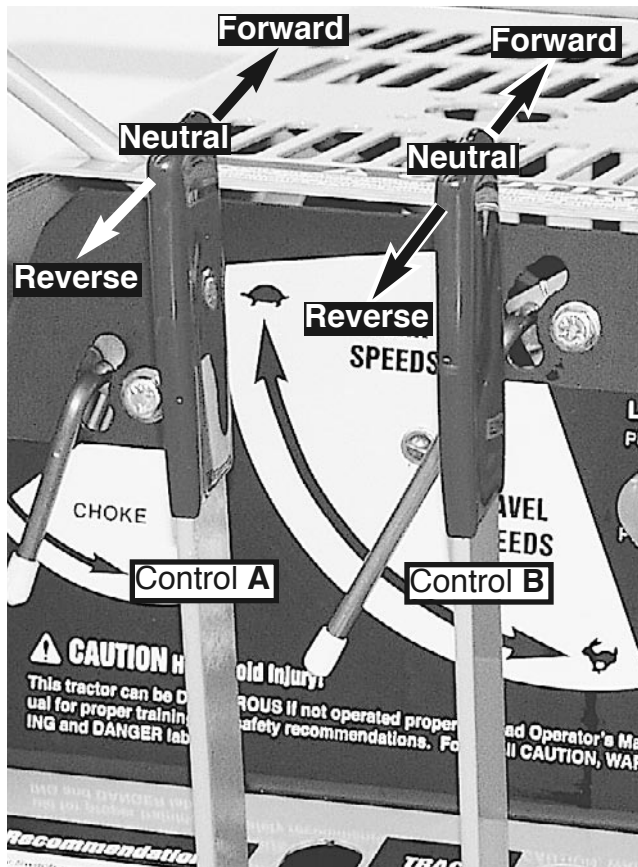

To turn **sharply to the left**, push Right Track Control fully forward...leave Left Track Control in neutral.

To turn **slowly to the left**, push Right Track Control fully forward while simultaneously pushing “partially” forward on the Left Track Control...the farther you push the Left Track Control forward, the slower you will turn to the left.

To **counter-rotate Tracks**, (shortest turn possible), push one Track Control forward while simultaneously pulling rearward on the other Track Control. You may counter-rotate “clockwise” or “counter-clockwise”; move in which ever direction satisfies the job at hand.

**Stopping the Crawler:** The Right and Left Track Controls are of the self-centering (neutral) type. This allows you to simply release pressure on both Track Controls to disconnect (declutch) active power to the Tracks and come to a complete stop. **Never** “snap” Track Controls back into neutral!

## PARKING THE CRAWLER

1. Lower all Attachments to the ground.
2. Allow Right and Left Track Controls to go “slowly” to neutral.
3. Engage Parking Brake.
4. Run Engine at half speed 2 minutes without load.
5. Move Throttle Control to slow idle.
6. Turn Ignition Switch to Off.

**IMPORTANT:** If Engine stops under load, remove load. Start Engine immediately. Run 30 seconds at half speed before adding load.

In freezing weather, park on a hard surface to avoid freezing the Tracks to the ground. If Tracks are frozen to the ground, be careful to avoid damage to the Tracks and drive train when you try to move the Crawler.



**CAUTION:** When you park your Crawler on a slope, put blocks against tracks. **Do not** park Crawler with tracks pointed downhill, always park “cross-ways” to the hill!

# FUELS and LUBRICANTS

## FUELS

### FUEL SPECIFICATIONS

Check enclosed Engine Owner's Manual and closely follow their recommendations.

### FILLING FUEL TANK

The Fuel Tank is located to the left of the Operator's Seat.

Fill Fuel Tank at end of each day's operation.

Fuel Tank capacity is 5.6 U.S. quarts.

Use unleaded gasoline per Engine Owner's Manual.



**CAUTION:** Handle fuel carefully. Do not fill fuel tank when the Engine is running. Do not smoke while you fill fuel tank or work on fuel system.

### STORING FUELS

Keep fuel in a container in a protected area. Water and sediment must be removed before fuel gets to the Engine. Do not depend on fuel filters to remove water.

If possible, install a water separator at the storage tank outlet.

Store fuel drums on their sides with plugs up.

**IMPORTANT:** Keep all dirt, scale, water, or other foreign matter out of fuel.

## LUBRICANTS

### ENGINE OIL

Check enclosed Engine Owner's Manual and closely follow their recommendations.

### GREASE

Use premium quality SAE Multi-Purpose Grease in a grease gun with a flexible "nose".

### STORING LUBRICANTS

Store lubricants in clean containers in an area protected from dust, moisture, and other contamination.

# LUBRICATION and PERIODIC SERVICE

## LUBRICATION AND SERVICE INTERVALS

Recommended service intervals are for normal conditions. Service more often if Crawler is operated under more difficult conditions such as high temperature, dust, etc. Use only quality lubricants at intervals specified in this manual.

## PERIODIC SERVICE CHART

### DAILY OR EVERY 10 HOURS

#### Engine Air Cleaner

Service per instructions in Engine Owner's Manual.

#### Engine Oil

Service per instructions in Engine Owner's Manual. **NOTE:** First oil change for a new Engine is at 5 hours.

#### Grease Zerks

Lubricate all zerks per instructions in manual of each attachment you have mounted to, or are operating with your Crawler. [Clean zerks and area around them before servicing].

#### Front Idler / Rear Drive

Your Crawler is pre-lubricated at the factory for the first 25 to 50 hours of operation [25 hours for dusty, gritty conditions; 50 hours for normal conditions]. After that period you may use one of the following lubrication procedures:

**Normal Conditions:** Clean area around each "zerk" in Front Idler and Rear Drive Assemblies. Remove zerks...try to have them on the "top-side". Using an oil can with SAE 30 motor oil, fill each reservoir through threaded hole...do this at day's end to allow oil to soak into the bearings

overnight. Repeat oiling next morning and replace zerks. Repeat process every 25 hours.

**Dusty Conditions:** Clean area around each "zerk" on Front Idler and Rear Drive Assemblies. Grease each zerk until you see, or feel, grease coming out the bearing ends.

#### #1791 Bearing Assemblies

Lubricate the "zerk" in each #1791 Bearing Assembly. **NOTE:** The #1791 Bearings are the hardest working Bearings in your RS1000, never spare proper lubrication and maintenance!

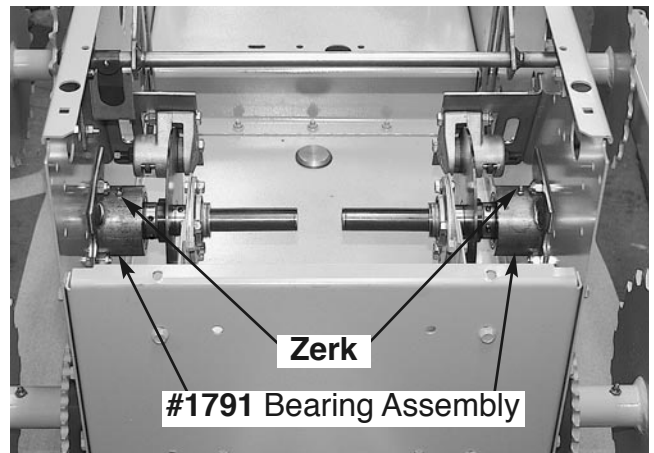

#### Track Tension

Maintain 1-3/8" overall length of #1806 Spring on each Track. Check Service section of this Manual for complete explanation and Track Tensioning procedures.

#### Rear Drive Chain Tension

Maintain proper chain tension in Crawler's Rear Drive. Check Service section of this Manual for complete Rear Drive Chain Tensioning procedures.

#### Rear Drive Chain Lubrication

Use SAE 30 motor oil in pressure oil can. Thoroughly lubricate each Drive Chain. [TIP: Drive Crawler forward approximately six feet stopping to oil the Chain every foot]. Don't forget to do both Drive Chains!

**NOTE:** Though your model crawler may have "deluxe" rear drive chains requiring minimal to no lubrication, it still will add more life to your chains to occasionally oil them or periodically remove them and soak in oil overnight.

### **Engine Drive Chain Tension**

Maintain proper chain tension in Crawler's Engine Drive Chain. Check Service section of this Manual for complete Engine Drive Chain tensioning procedures.

### **Engine Drive Chain Lubrication**

Use SAE 30 motor oil in pressure oil can. **With Engine Stopped and Ignition OFF**, thoroughly oil chain as you rotate it with the recoil starter rope. Tip: wipe the chain down after oiling to keep oil spatter to a minimum.

**NOTE:** If you have a model crawler with a "deluxe" Engine Drive Chain, you need not oil it for the life of the chain.

### **General Once-Over**

Check for loose nuts and bolts and any signs of premature wear. Correct any problems immediately. Contact factory with any questions or requests for help.

## **EVERY 200 HOURS**

### **Fuel Tank**

Remove and drain tank of any water or sediment. Clean or replace the **in-tank** fuel filter.

## **EVERY 50 HOURS**

### **Engine Oil**

Drain and refill per recommendations in Engine Owner's Manual.

**NOTE:** Change Engine oil every 25 hours if you're working under constant heavy loads or extremely dirty conditions.

### **Battery**

Check electrolyte level (if applicable) and fill with distilled water to the bottom of the filler neck.

### **Filters**

Replace Engine Air Filter with filter recommended in Engine Owner's Manual.

### **Tracks and Track Sprockets**

Remove and pressure wash Track. Pressure wash Front Idler and Rear Drive Sprockets.



# SERVICE

In the following Service section of this Manual, you will be required to do various assembly and disassembly procedures. Each section will try to remind you of safe procedures, but the best safety device is still the mechanic himself.



**CAUTION:** Try to do your work in a level, open area away from people and obstacles.

1. Pay attention to what you are doing..the parts you will be handling can be heavy, sharp or could pinch. Always wear heavy gloves when handling the Tracks and similar sharp, pinching parts.

2. When you are required to block your crawler to raise it off the ground, make sure you use strong blocking materials and think out how the Crawler will safely balance on blocking. **To protect yourself and your Crawler from damage, check “Safe Blocking Diagram” on front page of this Manual!**

Never be too proud to ask a friend or neighbor for help...especially when blocking up your Crawler or working with the Tracks.

As always, the factory is your best source for competent service advice and explanations of any service procedures that are unclear...always feel comfortable calling for whatever advice you may need!

## ENGINE

Your Crawler comes with a complete Engine Owner’s Manual. It provides complete operation and maintenance instructions for your engine. If further help is needed, contact your local engine dealer...he’s listed in the telephone “Yellow Pages” under “Engines, gasoline”.

## STARTER

**IMPORTANT:** Don’t operate starter switch longer than 10 seconds at a time. If Engine does not start within 10 seconds, wait 60 seconds before trying to start again. After a false start, do not push starter button until Engine has stopped turning.

If the starter will not operate or operates sluggishly, check for the following:

- Run down battery.
- Dirty, loose, or corroded cables and wires.
- Engine oil viscosity too heavy.

## BATTERY

Your Crawler has a 12 volt, negative-grounded system with one battery (battery not included on recoil start models).

### BATTERY PRECAUTIONS



**CAUTION:** Sulfuric acid in batteries is a poison and could cause severe burns. Avoid contact with skin, eyes, and clothes. When you work around batteries, protect eyes and face from battery fluid and explosion.

Antidotes for Sulfuric Acid:

#### EXTERNAL

1. Flush skin well with water.
2. Flush eyes for 15 minutes.
3. Get medical attention immediately.

#### INTERNAL

1. Drink a large amount of water or milk.
2. Then drink milk of magnesia, beaten eggs, or vegetable oil.
3. Get medical attention immediately.



**CAUTION:** Keep flames and sparks away from battery.

Do not use booster cables or adjust battery terminal connections unless you know the correct procedure.

When you charge a battery or use a battery in a closed space, be sure there is enough ventilation.

Keep batteries where children cannot reach them with vent caps tight and level.

## COLD WEATHER BATTERY SERVICE

During cold weather, keep electrolyte in battery at correct level (if applicable). Keep battery fully charged.

## BATTERY STORAGE

If Crawler will be stored for more than 30 days, remove battery. Keep it fully charged.

## BATTERY MAINTENANCE

1. Remove corrosion from terminals with a stiff, non-metallic brush.



**CAUTION:** Use care when cleaning terminals so that you do not “short them out” with metallic brushes, scrapers, screwdrivers etc.

2. Clean battery with a baking soda solution (1/4 pound in a quart of water)...best done with battery removed from crawler.

3. Flush battery and compartment with clear water.

4. Check electrolyte level (if applicable). Fill each cell to bottom of filler neck with distilled water or clean, soft water (not hard water).

5. Put petroleum jelly on terminals. Maintain protective cover on “positive” (+) terminal of battery.

## SAFETY INTERLOCK SWITCHES

Two Switches, one on underside of the #933A Seat and the other one on the Brake Lever Rod inside Crawler.

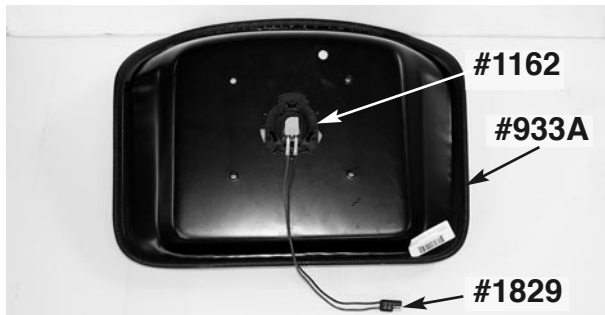

These switches are used in the Crawler’s electrical system as safety devices. They detect if the

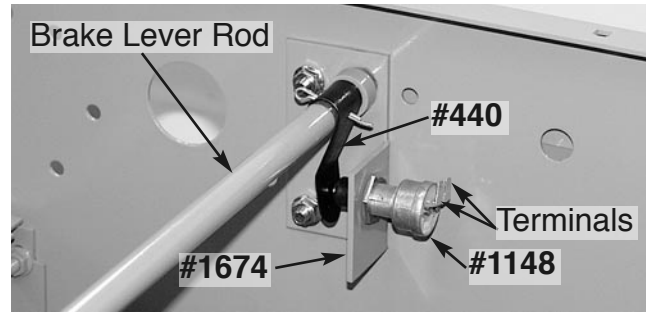

operator is properly seated, and that the Parking Brake is engaged before the Crawler can start.

To check either the #1162 Seat Switch or the #1148 Parking Brake Switch, you must remove the electrical connectors attached to each switch’s terminals and connect a continuity tester to its terminals (a simple flashlight type continuity tester would be fine).

## SEAT SWITCH TEST

Remove #933A Seat from its #1674 Seat Mounting Bracket. Then remove the electrical connectors attached to each of the #1162 Seat Switch’s two terminals.

1. By pushing down on the center of the seat the Seat Switch should “open”. A continuity tester, attached to the two terminals of the Switch, should have its light Off at his time!

2. With pressure removed from the seat, the Switch should “close”...the light should be On!

If both of the above conditions are not met, the Switch is defective and must be replaced. When test is completed, remove continuity tester and replace original electrical connectors on both terminals of Seat Switch. Remount seat to its Mounting Bracket.

Reassemble the Seat Assembly to your Crawler and reconnect it’s Plug.

At this time following recommended safe starting procedures, start the Engine and check Seat Switch response...readjust if necessary.

## PARKING BRAKE SWITCH TEST

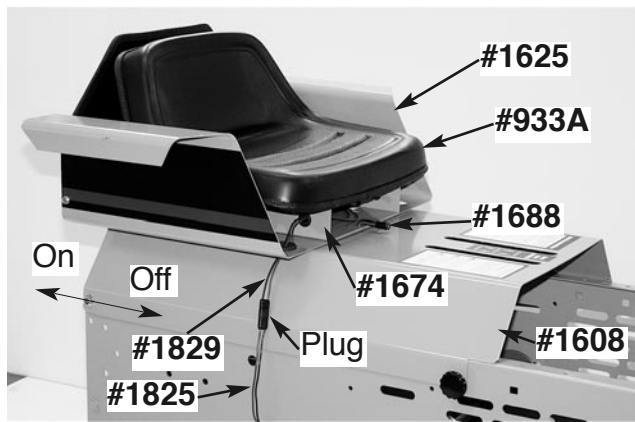

Begin your procedure by parking your Crawler on an open, firm, level surface. Shut off engine and engage Parking Brake. Open Hood and swing fully forward. Remove #1688 Seat Pin. Remove #933A Seat & #1674 Mounting Bracket, #1625 Arm Rests, and #1608 Rear Cover. **NOTE:** Be sure to disconnect the “mating” #1829 and #1825 Seat Wires at their common Plug.

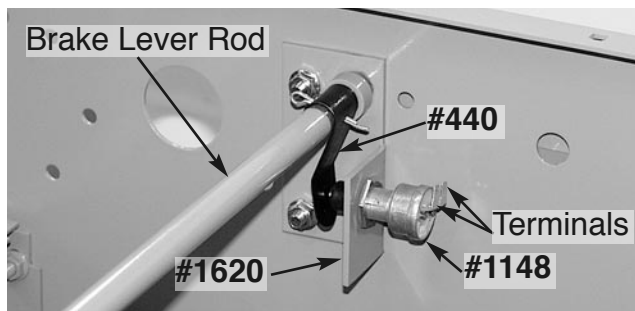

**Disengage** Parking Brake. Remove the two electrical wire plugs from their #1148 Parking Brake Switch and connect a continuity tester to its two terminals.

(1) With “plunger” of #1148 Parking Brake Switch not depressed, the light of the continuity tester should be On. With “plunger” of Parking Brake Switch fully depressed, the light of the continuity tester should be Off.

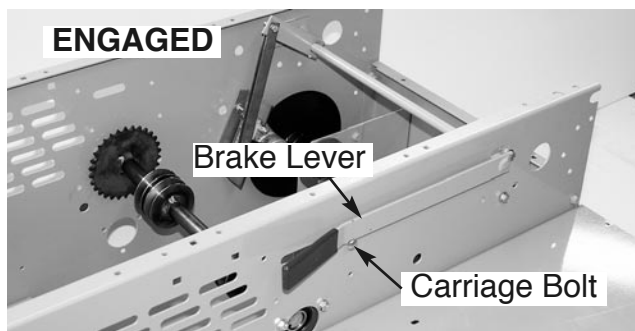

(2) When the Parking Brake Lever is pulled “upward” and looped “up and over” the Carriage Bolt

provided into an “engaged” position, Parking Brake Switch should be “open” (the result of contact with the rotated #440 Leaf Spring). The light of the continuity tester should be Off!

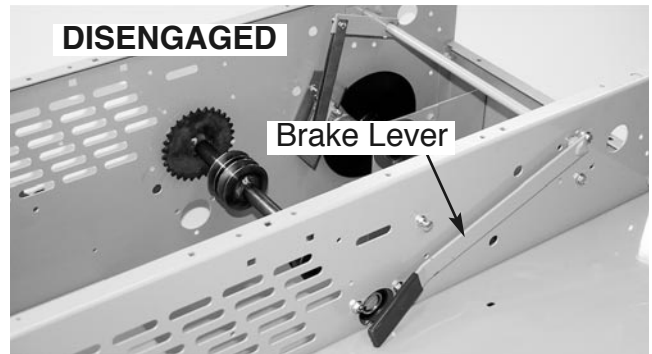

(3) When the Parking Brake Lever is released and put into its “disengaged” mode (Lever should be free to touch Left Fender) the Parking Switch should be “closed” (the Leaf Spring would have rotated back and away). Continuity light should now be On!

If both conditions of procedure (1) (above) are not met, replace Parking Brake Switch. If both conditions of procedure (1) are met, but the conditions of procedure (2) & (3) are not met, you must adjust the “horizontal location” of the #1148 Switch in its #1620 Bracket.

The #1148 Parking Brake Switch is secured “front to rear” in its #1620 Bracket with hex nuts.

Adjust Switch’s location “front to rear” to meet requirements (1), (2) and (3) (above) by relocating its two hex nuts.

When adjustment is completed, tighten Switch’s hex nuts...terminals on Switch should point straight up. Remove continuity tester and replace electrical plug on terminals of Switch. Replace Seat & Mounting Bracket, Arm Rest and Rear Cover Assembly...check that it is positively latched with #1688 Seat Pin! Close Hood and secure it and Rear Cover with #1866 threaded Knobs.

**NOTE:** Be sure to reconnect “mating” #1829 & 1825 Seat Wires at their common Plug.

At this time, following recommended safe starting procedures, start the Engine and check Parking Brake’s Switch setting...readjust if necessary.

## REAR DRIVE CHAIN TENSIONING

The #1805 Rear Drive Chains (#50 Roller Chain) are tightened by increasing the center distance between the **movable** #2065 Rear Axle and the **fixed** #2048 Sprocket & Shafts.

Begin your Drive Chain Tensioning procedure by driving Crawler onto a firm, level surface. Shut off Engine and dismount...do not “engage” Parking Brake Lever.

*[Though not absolutely necessary, it's extremely helpful in the following procedure to block your Crawler up and remove its Tracks...see Track Removal section of this Manual for instructions].*

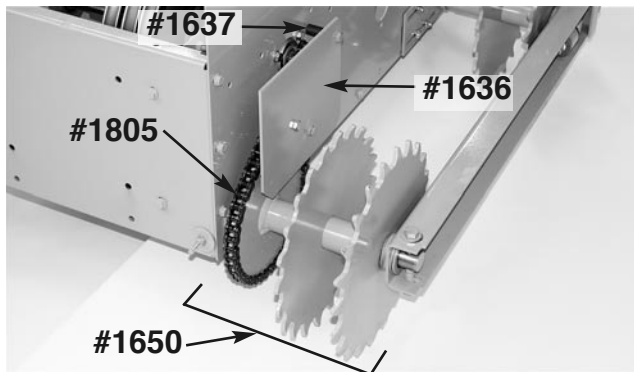

Open Hood and swing fully forward; remove #1688 Seat Pin. Remove Seat & Bracket, Arm Rests and Rear Cover. Remove the #1636 Right & Left Chain Guards from left and right sides of Crawler.

Do a thorough washing and cleaning of the #1805 Chains and mating Sprockets with a powerwasher or a stiff brush. The Sprockets and their mating

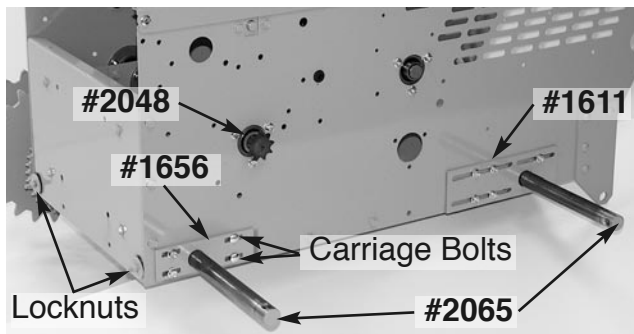

Drive Chains must be clean to give proper chain adjustment. [Remove the Drive Chains and soak in penetrating oil overnight if stiff].

From “outside” the Crawler’s body, loosen (but do not remove) the five nuts on each (Left & Right) #1611 Front Axle Plate. Similarly loosen, but do

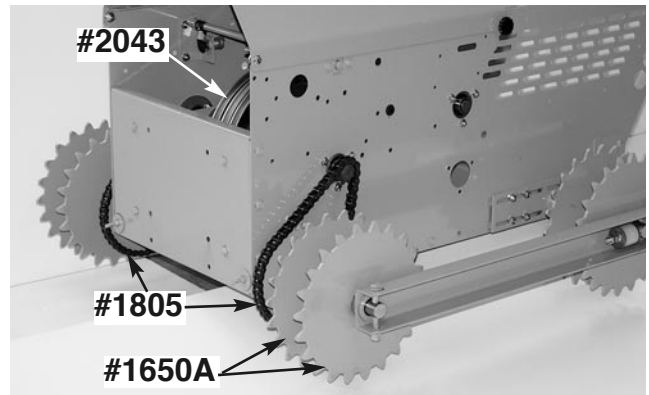

not remove the four nuts on each (Left & Right) #1656 Rear Axle Plate. **NOTE:** loosen the Carriage Bolt “nuts” from inside of body, all others from outside.

On each side, from inside body, rotate each #2043 Pulley Assembly. Check that each #1850 Drive Chain is moving smoothly and that it is free of debris.

[TIP: It will ease rotating the Pulley Assemblies (above) if you follow the procedure for “Removal - Steering Clutch Belts” in Service section of this Manual. Replace Belts per “Installation - Steering Clutch Belts” in Service section of this Manual after you have completed your chain tensioning].

To tighten the Drive Chains, start rotating **clockwise** the Locknut located on left and right lower rear of Body. To draw Rear Axle back evenly, turn

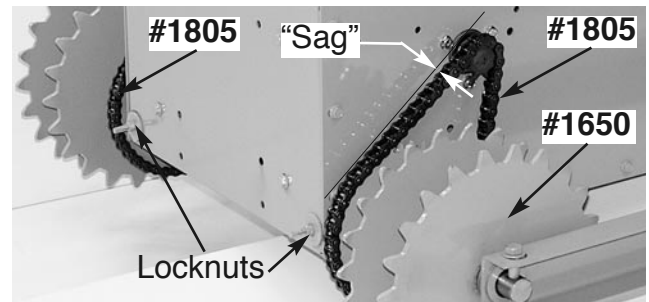

one Locknut 1/4 turn, then go to the other side and tighten the other Locknut 1/4 turn...use this back and forth procedure until both #1805 Drive Chains are reasonably tight...not “bow-string” tight, but about a 1/4” of “sag” in the slack strand when the balance of the chain is taught.

**NOTE:** While doing the above procedure, make sure you rotate each #1650 Rear Track Sprocket Assembly (left side & right of body) a full revolution after each 1/4 turn of its respective Locknut. This will determine if there is a slight “high spot” in one of the (#1805 Chain) mating sprockets...if so, use

the “high spot” location for your point of tightening. When satisfied that both Drive Chains are tightened evenly, retighten the four Bolts holding the #1656 Rear Plates on left & right side of Body. Thoroughly lubricate your Drive Chains at this time.

Replace the #1636 Right & Left Chain Guards using original Cap Screws, #1637 Spacers, and Nuts . Replace Seat Assembly, Arm Rests and Rear Cover and close Hood...secure all with #1866 “threaded” Knobs.

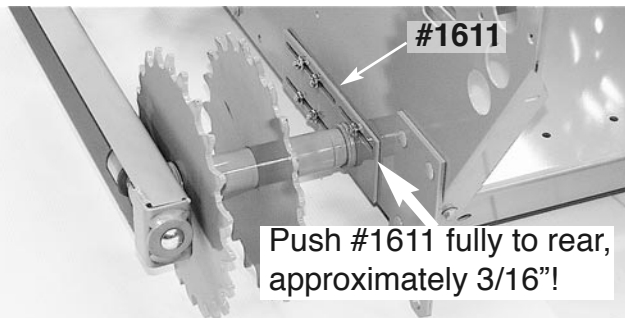

Using a “flat-nosed” punch and hammer, push the #1611 Front Axle Plate (located on both sides of Body) rearward till it hits a solid stop. **NOTE:** in the work done in steps above, this Plate may have already worked its way rearward. To check, push Plate forward from the rear, then push it back the required 3/16” distance.



**NOTE:** Though this is a simple adjustment, it’s proper execution now will result in extremely stable Track performance in the future!

If you have removed your Tracks, reassemble them on your crawler at this time using the “Track Replacement” instructions in Service section of this manual...make sure to properly tension them.

## PARKING BRAKE ADJUSTMENT

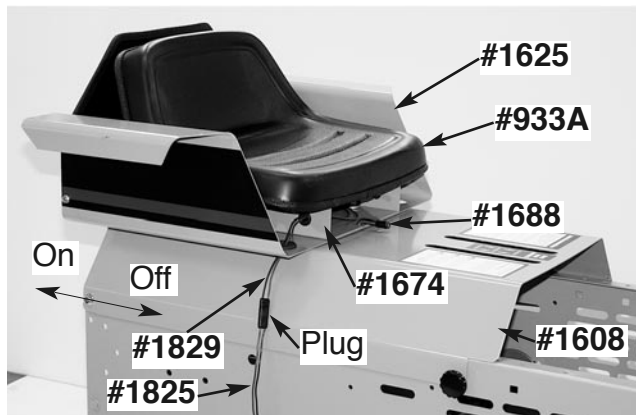

Begin your procedure by parking your Crawler on an open, firm, level surface. Shut off Engine, en-

gage your Parking Brake Lever and dismount. Raise Hood and rotate it fully forward, then remove the #1688 Seat Pin. Remove the #933A Seat & #1674 Mounting Bracket, #1625 Arm Rests, and #1608 Rear Cover. **NOTE:** Disconnect the “mating” #1829 and #1825 Seat Wires at their common Plug.

Put the Parking Brake Lever in the disengaged position...end of Lever should be free to touch top of Left Fender.



Loosen Jam Nut on the #225L Left & #225R Right Disc Brake Calipers a few turns to free their Adjuster Pins for rotation (see two Photos below).

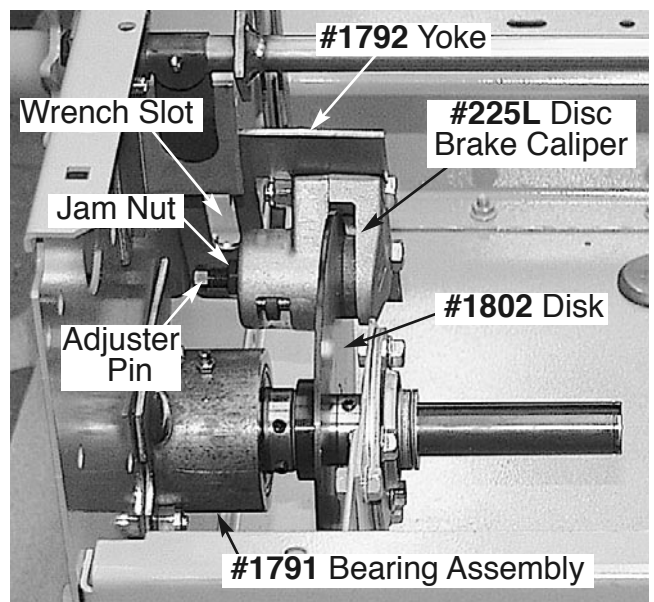
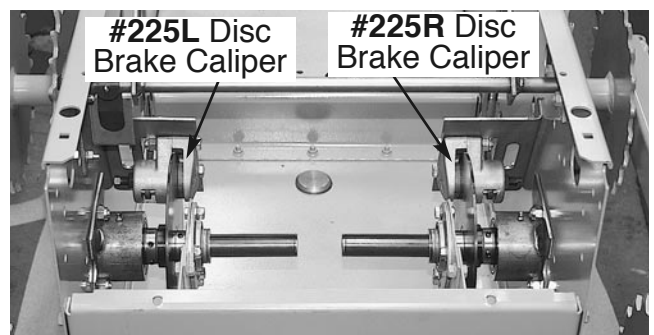

With Brake Lever firmly touching *underside* of Carriage Bolt, set *each* Brake’s tension by rotating it’s Adjuster Pin *clockwise* until the the Pulleys on each side are not able to be *easily* rotated by hand.

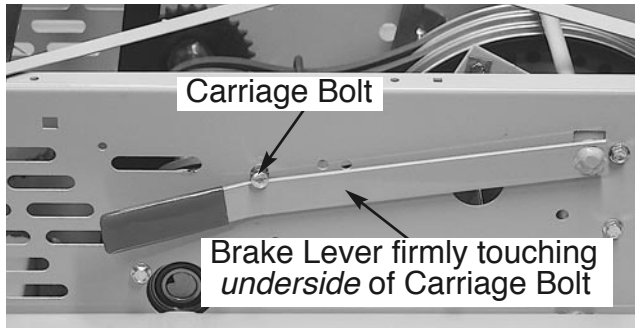

Tighten each of these Brake Assemblies by holding their Adjuster Pin “motionless” with one wrench while tightening their respective Jam Nut securely... a Wrench Slot is provided in each #1792 Yoke (see Photo previous page, lower right).

Engage Parking Brake by pulling up on Brake Lever and draw it up, over, and behind the head of the Carriage Bolt stop.

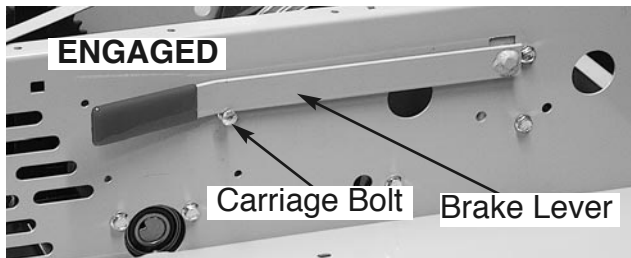

**NOTE:** In the process of making Brake adjustments, try to keep *both* Brakes synchronized with each other for even braking! CHECK WITH FACTORY IF YOU HAVE ANY QUESTIONS REGARDING YOUR BRAKE ADJUSTMENTS!

Close Hood, then Replace Seat Assembly, Arm Rests and Rear Cover...secure all with #1866 “threaded” Knobs. **Reconnect** mating #1829 & 1825 Plugs.

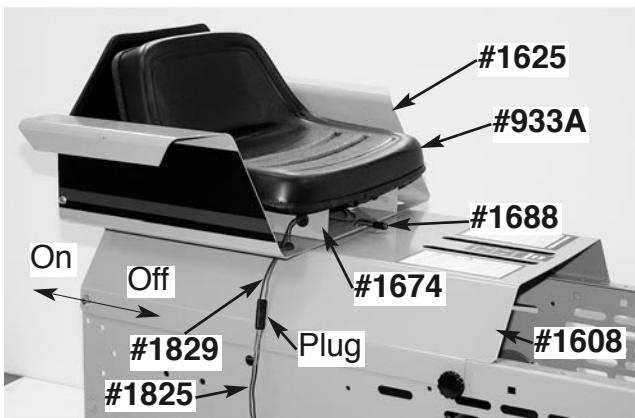

## TRACK CLUTCH BELTS

The following segment is divided into three sections:

- 1) **Belt Removal.**
- 2) **Belt Installation.**
- 3) **Belt Adjustment.**

It's suggested that you read all three sections that follow to gain an overview before you begin any work. You can then return to the sections that apply to the job you're doing.

**NOTE:** In the following photos many are “cut-aways” of an actual crawler which were created to best illustrate the points covered in the following instructions. Though the components are actual crawler parts, many associated parts are missing.

**SPECIAL NOTE:** Though all six Track Clutch Belts are identical and carry the same part number (#2078), for simplicity they are designated in the following drawings and descriptions as Belts #1 through #6. In a similar manner, the Pulleys have their own part numbers (#2043 - 14” dia. and #2041B - 3” dia.), but in the following instructions they will be designated as Pulleys AA through LL.

Begin your procedure by parking your Crawler on an open, firm, level surface. Shut off Engine, engage your Parking Brake Lever and dismount.

Raise Hood and rotate it fully forward; remove the #1688 Seat Pin. Remove the #933A Seat & #1674 Mounting Bracket, #1625 Arm Rests, and #1608 Rear Cover. **NOTE:** Be sure to disconnect the “mating” #1824 and #1825 Seat Wires at their common Plug. (see Photo at left)

Pull the #910 Hitch Pins and remove both #1638 Spring Rod assemblies...leave Springs, and Collars in place on each Rod.



Remove the 3/8" nut securing each #1629 Belt Release. Remove both Belt Releases.

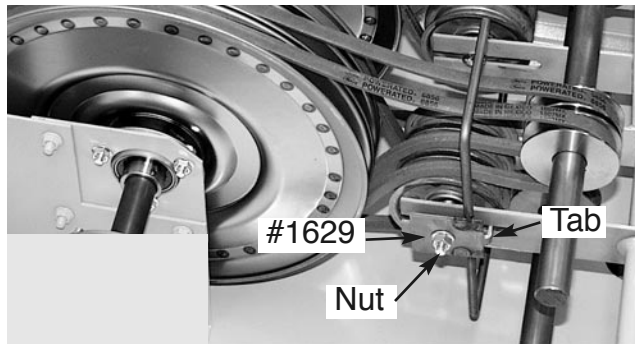

## BELT REMOVAL

Remove Belts #3 and #4 from their mating CC & JJ and DD & II Pulleys by slipping them first off their larger II & JJ Pulleys (14" diameter) and then off their smaller CC & DD Pulleys (3" diameter). [Belts should be moved inwardly toward each other and remain at center of Crawler].

**HINT #1:** In the removal of Belts #3 & #4 (above) you will gain extra "slack" in each Belt by pushing forward on the Control Handles as you slide the Belts off their respective Pulleys.

**HINT #2:** In the removal of Belts #2, #5, #1 and #6 (below), you will gain extra "slack" in the Belts by pulling rearward on the Control Handles as you slide the Belts off their respective Pulleys!

In a similar manner as above, move Belts #2 and #5 from their mating BB & KK and EE & HH Pulleys and locate them in center of Crawler.

[**Tip:** Slip Belt #2 off its BB Pulley first and then work it off its KK Pulley and then the JJ Pulley. Similarly, slip Belt #5 off its EE Pulley first and then work it off its HH Pulley and then the II Pulley].

Lastly, move Belts #1 and #6 from their mating AA & LL and FF & GG Pulleys and locate them in center of Crawler. [**TIP:** Slip Belt #1 off AA Pulley and around BB Pulley. Slip Belt #1 off LL Pulley and around KK Pulley. Slip Belt #1 off BB Pulley. Now work #1 Belt off KK Pulley and then over and off JJ Pulley.

In a similar procedure, slip Belt #6 off FF Pulley and around EE Pulley. Slip Belt #6 off GG Pulley and around HH Pulley. Slip Belt #6 off EE Pulley. Now work #6 Belt off HH Pulley and then over and off II Pulley].

## CREATING BELT SLOT

The following steps cover the moving of the #252B Bearing (located on the top center inside Wall of Crawler) "inwardly" on the #1627 Upper Power Shaft to create a "slot" for the belts to move through, to be removed or new ones installed. **NOTE:** Though not shown, these instructions also apply to the likewise moving of the #252B Bearing "inwardly" on the #1643 Lower Power Shaft.

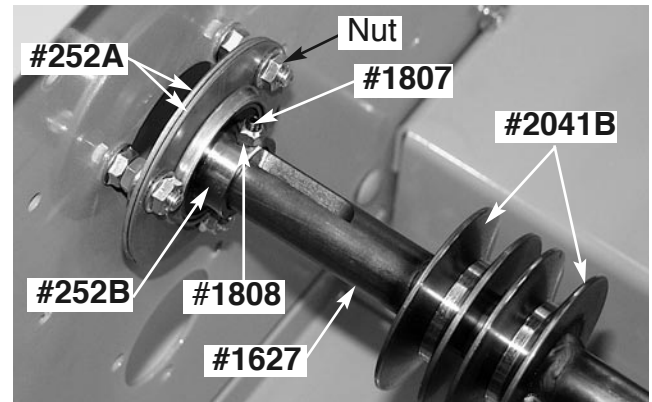

Using the proper sized "Allen Wrench" to hold the #1807 Set Screw, take a proper sized "open end" wrench and turn the #1808 Locking Jam Nut two full turns "counter-clockwise". Then use the Allen Wrench to completely remove this "set screw & nut" assembly...save for reinstallation.

Remove the three nuts securing the pair of #252A Shells holding the #252B Bearing. Slide this Bearing & Shells assembly "inwardly" to reveal a slot between the "end" of the #1627 Shaft and the Body Wall (Photo below).



**CAUTION:** Do Not put strong forces on the now "unsupported" left ends of the #1627 Upper & Lower Power Shafts! Shafts were factory aligned when the Crawler was manufactured to allow easy re-mounting of the Bearings that you have temporarily removed to create a "slot" on each Shaft end.

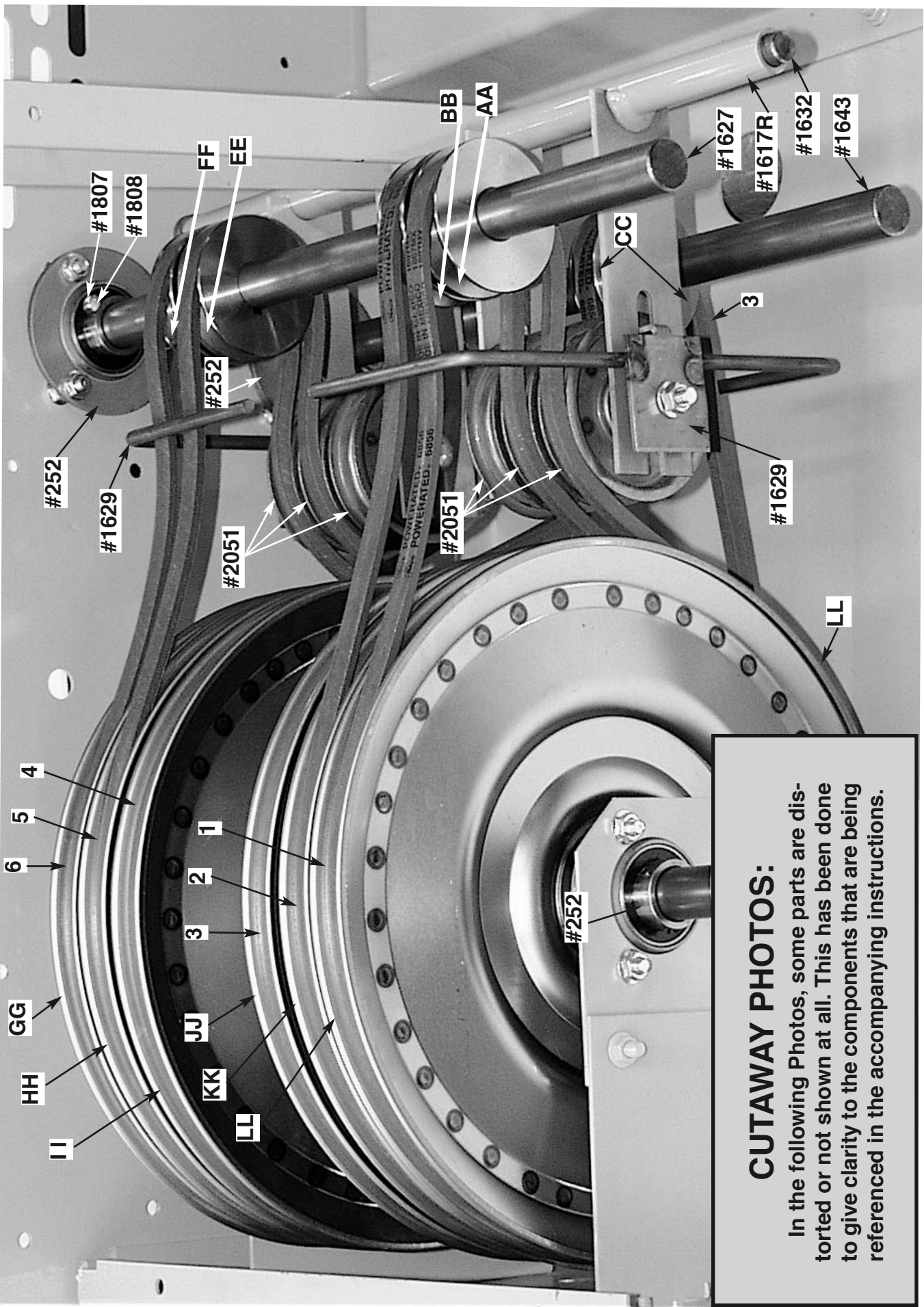

**CUTAWAY PHOTOS:**

In the following Photos, some parts are distorted or not shown at all. This has been done to give clarity to the components that are being referenced in the accompanying instructions.



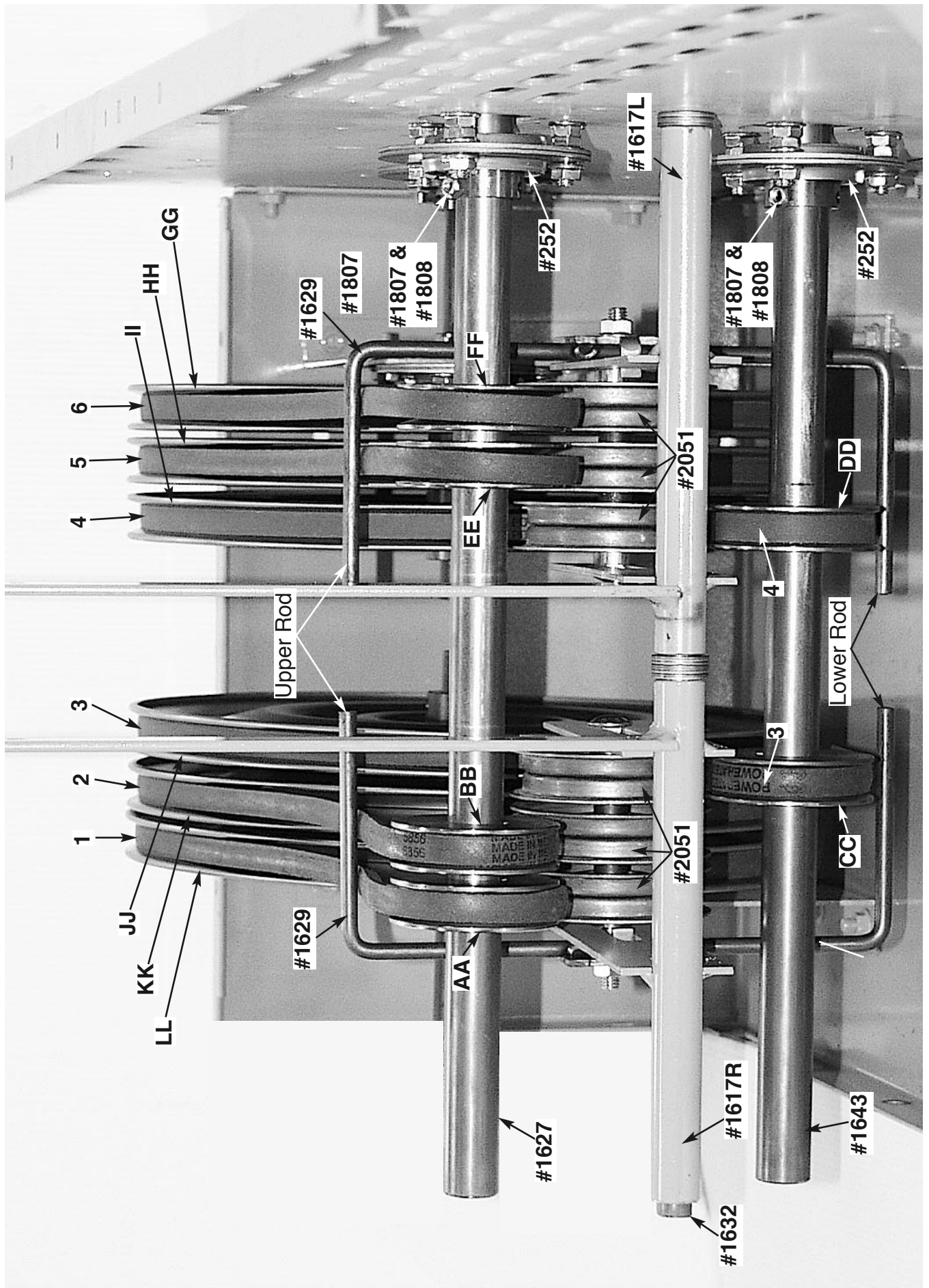

At this time you can move to your left, the Belts you wish to remove from the system. Slip them through their respective “slot” exposed when you moved “inwardly” the #252B Bearing Assemblies on the #1627 Upper & #1643 Lower Power Shafts.

## BELT INSTALLATION

**EXPLANATION:** The Belts used in your Crawler are special. Do not confuse them with inexpensive, fractional horsepower consumer Belts.

Your Crawler Belts are made for difficult, high horsepower, shock load, industrial applications. Formulated with industrial grade rubber compounds, they feature a Kevlar (bulletproof plastic) cabled core. Molded around each Belt is a special fabric jacket that forms the Belt’s “clutch face”.

In an hour or so of operation this fabric jacket gains a smooth “glaze” and forms the clutch face necessary for smooth Track Clutch engagement.

**CAUTION:** NEVER, NEVER, use fractional horsepower Belts in your Crawler. They are made with light weight, “sticky compounds” that will not form a proper glaze. This means you will not have the SAFE clutch action mandatory for SAFE Crawler control! In addition, fractional horsepower Belts will break during shock loads and will leave your clutch system out of control!

**NOTE:** During the first hour or so of “breaking-in” a new set of Belts, you potentially may hear a squealing sound when turning. Do not be alarmed. This is characteristic of a new set of Belts until they have become permanently “glazed” and gain proper smooth clutch action.

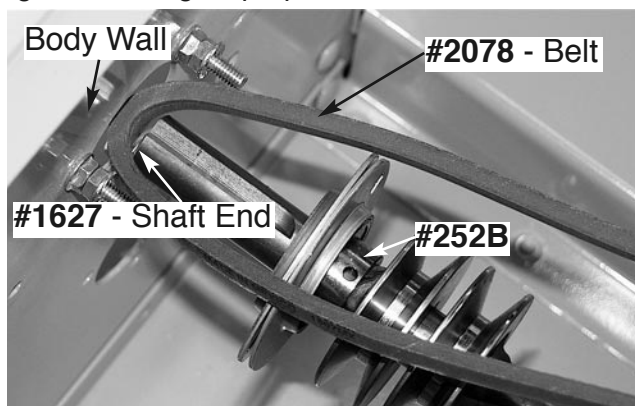

Slip the Track Clutch Belts you are installing through the “slot” you created on the “end” of the appropriate #1627 Upper and #1643 Lower Power

Shaft. [Belts #1, #2, #5 & #6 on the Upper Power Shaft; Belts #3 & #4 on the Lower Power Shaft]. Slide them to the center of your Crawler.

**SPECIAL NOTE:** It’s mandatory that you keep “left ends” of the Upper & Lower Power Shafts properly lubricated. A film of grease must totally cover the Shaft ends from the #2041B Pulley to the “left end” of each Shaft! As you grease the Shaft, work the #252B Bearing back and forth to make sure it’s completely coated! To ignore this procedure may make it impossible to slide the Bearing to change Belts in the future, which would require serious drive train rebuilding to correct the problem (see Photo below).

With the (above) lubrication completed, slide the Bearing & Shells assembly on left end of each Upper & Lower Power Shaft back into position on the “threaded studs” protruding from crawler wall. Replace original nuts over Bearing threaded studs and tighten.

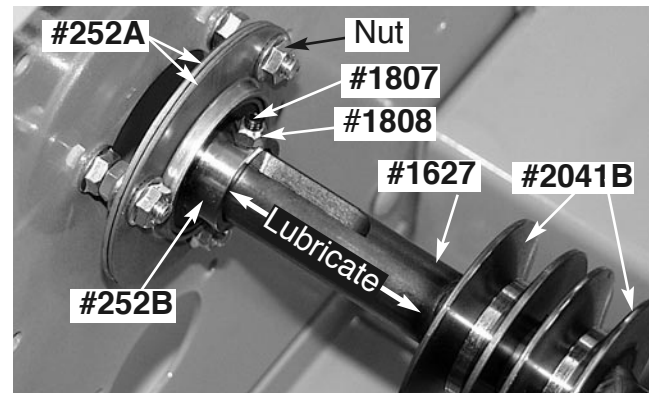

Take original #1807 Set Screw & #1808 Nut “assembly” and thread it into its original threaded hole of bearing...rotate the #1627 (or #1643) Shaft within the bearing to align the end of the #1807 Set Screw with its mating “V” slot in shaft’s end.

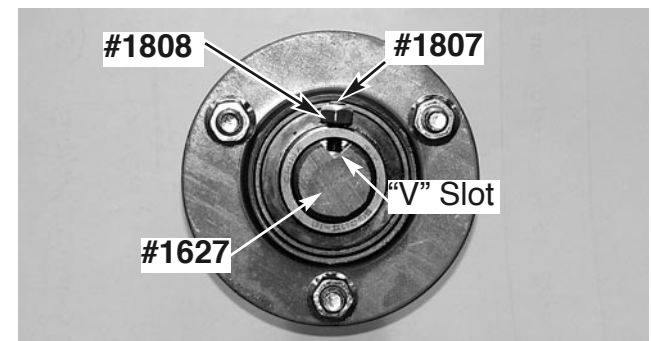

Use your Allen Wrench to tighten the Set Screw ...make sure it’s end hits the “V” slot “dead center”. With your “open-end” wrench tighten your

#1808 Jam Nut. (Use this procedure for **both** the Upper & Lower Power Shafts). When you are done the bearing end of shaft should look like photo (previous page).

Arrange the Belts and note that the two Belts on the Lower Power Shaft will be Belts #3 & #4 and will remain in the center (to be installed last). Locate Belts #1 & #2 (on Upper Power Shaft) just to the right of the #3 Belt. Locate the remaining Belts #5 & #6 (on Upper Power Shaft) just to the left of the #4 Belt.

**NOTE:** No single Belt can ever be around both the Upper and Lower Power Shafts at any one time!

Slip rearward end of Belt #1 first over JJ Pulley and then around KK Pulley. Now slip forward end of Belt #1 over BB Pulley and then around AA Pulley. Lastly, slip rearward end of Belt #1 around LL Pulley. [TIP: Pulling back on Track Clutch Control Handles during this and following procedures will give Belts more slack and ease installation].

In a method similar to step above, slip rearward end of Belt #6 first over II Pulley and then around HH Pulley. Now slip forward end of Belt #6 over EE Pulley and then around FF Pulley. Lastly, slip rearward end of Belt #6 around GG Pulley.

Slip rearward end of Belt #2 first over JJ Pulley and then around KK Pulley. Now slip forward end of Belt #2 around BB Pulley.

In a method similar to step above, slip rearward end of Belt #5 first over II Pulley and then around HH Pulley. Now slip forward end of Belt #5 around EE Pulley.

Slip forward end of Belt #3 around CC Pulley and then slip rearward end of Belt #3 around JJ Pulley. [TIP: Pushing forward on Track Clutch Control Handles during this step and the next, will give Belts more slack and ease installation].

In a method similar to step above, first slip forward end of Belt #4 around DD Pulley and then slip rearward end of Belt #4 around II Pulley.

At this point, each Belt should be in place and around its respective “pair” of Pulleys. Belts #1,

#2, #5, and #6 should be resting on “top” of their respective #2051 Flat Idler Pulleys. Belts #3 and #4 should rest “below” their respective #2051 Flat Idler Pulleys. Check photos and make sure each Belt follows its proper path from Pulley to Pulley and that it rests against (and between the raised “flanges”) of its respective #2051 Idler Pulley.

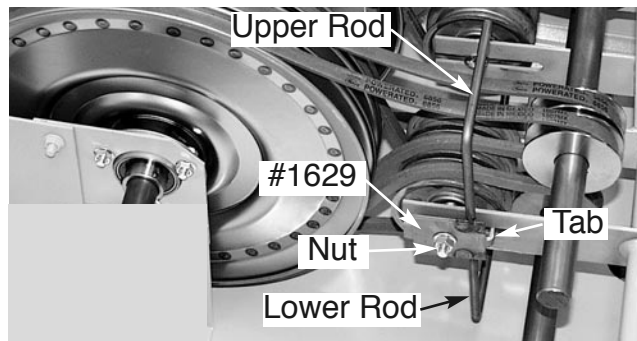

Replace both #1629 Belt Releases using original nuts to secure. **NOTE:** “TAB” goes forward on both sides.

Make sure Belt Release’s Lower and Upper Rods are always on the “outside” of the Belts ...**NEVER** inside!

Belt Release’s Upper Rods should be on **top** and **over** the outside face of its pair of Belts (#1 & #2 on the right; #5 & #6 on the left).

Belt Release’s Lower Rods should be **below** and **under** the outside face of it’s Belts (#3 on the right; #4 on the left).



Replace #1638 Spring Rods to the #1617 & #1632 Left & Right Clutch Handle Assemblies. Secure in place with #910 Hitch Pins.

## BELT ADJUSTMENT

Your Track Clutch Belts are adjusted as two “matched sets” of three belts each. One matched set (Belts #1, #2 and #3) for the Right Track and the other matched set (Belts #6, #5 and #4) for the Left Track.

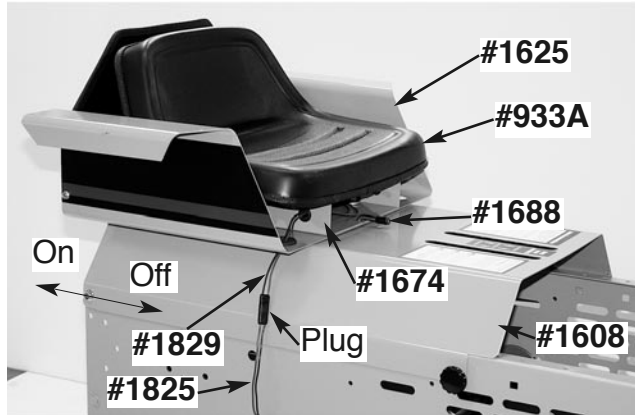

Begin your procedure by parking your Crawler on an open, firm, level surface. Shut off Engine, engage your Parking Brake Lever and dismount. Raise Hood, fully rotate it forward, remove #1688 Seat Pin. Then remove the #933A Seat & #1674 Mounting Bracket, #1625 Arm Rests, and #1608 Rear Cover. **NOTE:** Be sure to disconnect the “mating” #1829 and #1825 Seat Wires at their common Plug.

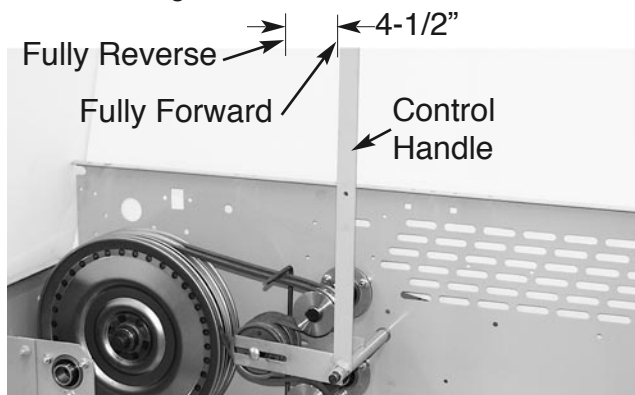

Determine if your Belts are in proper adjustment by measuring the distance of travel (forward to reverse) of each Control Handle. They should travel approximately 4-1/2” when measured at the “furthest end” of their Control Handles. If it is OK, close up your Crawler; **Don't forget** to reconnect #1824 & 1825 Wires & Plugs!

**If not**, follow the procedure below: Remove the 3/8” Nut securing each #1629 Belt Release...remove both Belt Releases.

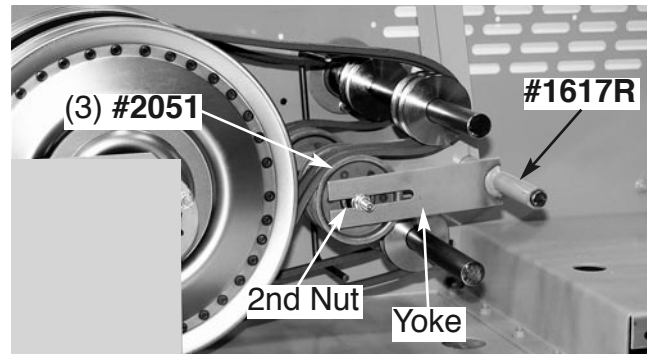
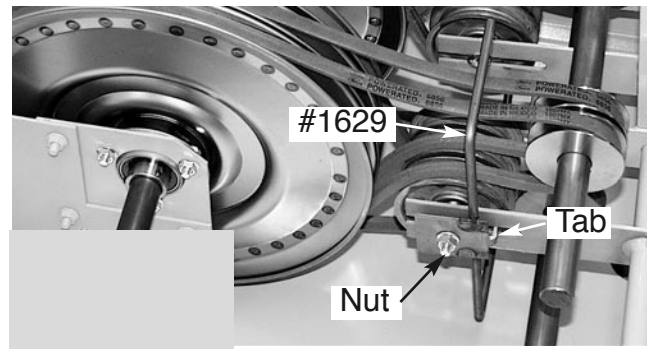

Loosen the 2nd 3/8” Nut holding each of the #2051 three Idler Pulley assemblies in place on their respective #1617R & 1617L Right & Left Control Handle Assemblies. Loosen, so each Pulley Assembly (containing three #2051 Idler Pulleys each) can slide forward and rearward in its respective Yoke.



Position each Pulley Assembly (forward or rearward) such that it's respective Control Handle can “rotate” a total distance of 4-1/2” (when measured at the “furthest end” of Control Handle). Complete this adjustment for both Right and Left Pulley Assemblies. When

satisfied with adjustment of both Pulley Assemblies, tighten the Locknut you loosened above.

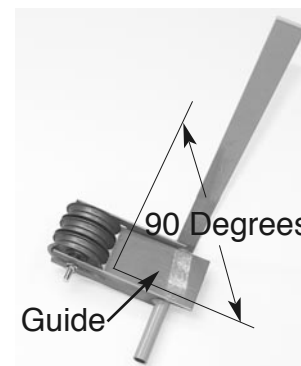

**NOTE:** as you tighten the (above) Locknuts you must keep the Pulley Assemblies at a 90 degree angle to the Yokes in each Control Handle assembly. Using a “home-made” sheet of metal, wood, etc. (approximately 3-1/4” x 6”) as a “guide” is a big help in holding this angle!

Replace both #1629 Belt Releases and secure each with original Locknuts. **NOTE:** Assemble such that “Tab” on both Belt Releases is “forward” of their Locknuts!.

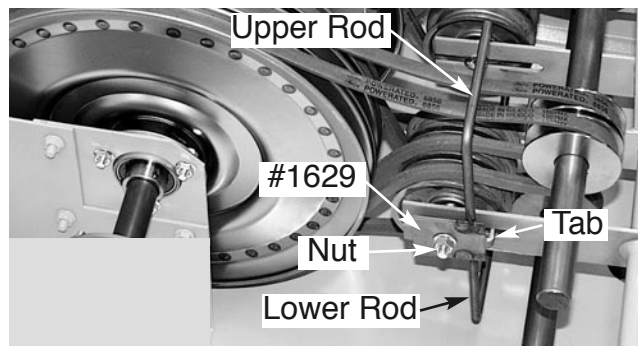

Make sure Belt Release’s Lower and Upper Rods are always on the “outside” of the Belts ...**NEVER** inside! Belt Release’s Upper Rods should be on **top** and **over** the outside face of its pair of Belts (#1 & #2 on the right; #5 & #6 on the left). Belt Release’s Lower Rods should be **below** and **under** the outside face of it’s Belts (#3 on the right; #4 on the left).

At this time “close-up” your Crawler following instructions for Seat & Rear Cover Assembly section (below). **Don’t forget** to reconnect #1829 & 1825 Plugs!

## TRACK MAINTENANCE

Before attempting to complete any part of this Track Maintenance section, it is recommended that you read all four parts (Track Removal, Track Replacement, Track Tensioning and

Maintenance Track Tensioning) to provide background on how the total Track System is adjusted and maintained.

Below are a series of drawings and photos to aid you in parts identification as you read the following procedures. For clarity, only the parts described in the instructions are included in the drawings and photos. In some cases, to lessen confusion, certain parts do not appear in all drawings and photos.

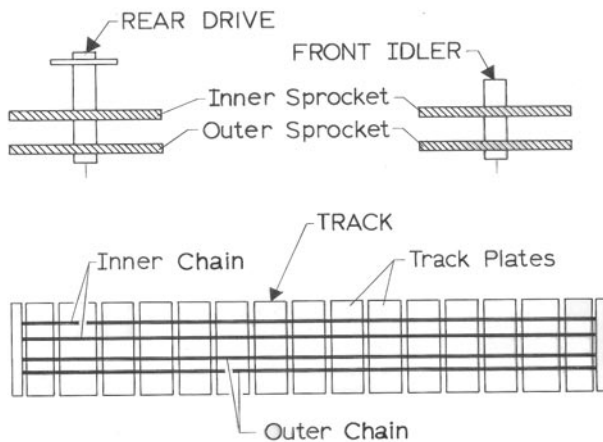

**CAUTION:** When working with the Tracks, you will be dealing with some significant weight and lifting situations. Though the Crawler can be successfully “blocked up” off the ground and the Tracks removed and replaced by a single person, it’s advisable to have an able-bodied “helper” available for both assistance and safety.

Begin any Track Maintenance procedure by checking that your Track System is relatively clean and free of debris...a high-pressure wash job is an excellent idea. In addition, drive your Crawler through a “clean area” to work out debris that may have lodged between Track Sprocket teeth or in the Track’s Chain Links. Park your Crawler on a firm level surface, shut off engine, set Parking Brake and dismount.

## TRACK REMOVAL

From below, support body of Crawler so its Tracks clear the ground by approximately 2” and are free to rotate...release Brake at this time.

Use solid blocking, place it under the Crawler’s Body per “**Safe Blocking Diagram**” on front page of this Manual. It will give the Crawler the greatest support left to right and front to rear. [When locating your blocking, analyze the total weight and balance of the Crawler as it will change as the Tracks are removed and then replaced!]

**NOTE:** As you work with the Tracks, realize that the more you can support the “lower strand” of each Track and keep it flat and close to its original operating level, the more slack you will have in the “upper strand” of the Track to work with!

Loosen and remove the 1/2” Jam Nut from the threaded end of each #1810 Tension Bolt. Then loosen and remove remaining 1/2” Locknuts, #1689 Washers, #1806 Springs, #1885 Tubes and 1/2” Washers.

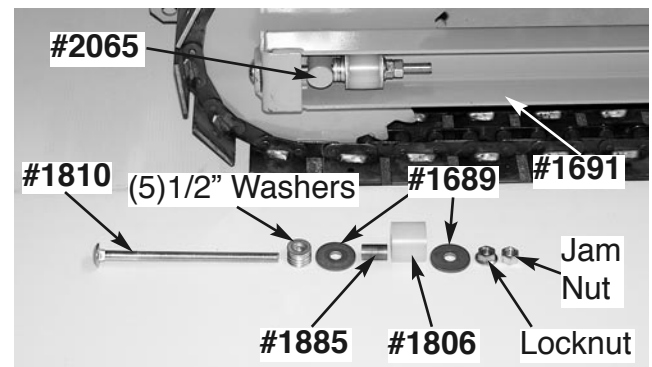

From “outside” the Crawler’s body, fully loosen (but do not remove) the five nuts on each (Left & Right) #1611 Front Axle Plate. Slide #2065 Axle fully rearward.

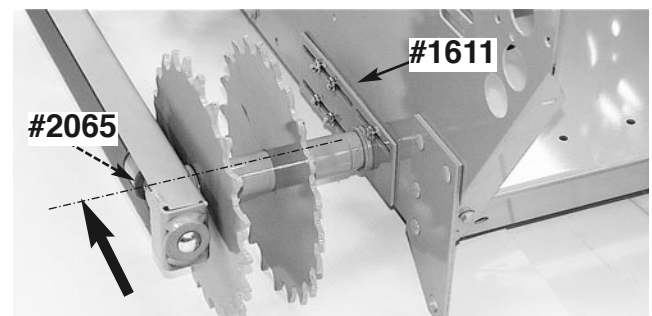

With gloved hands, begin to rotate the Track forward. [TIP: As you rotate the Track, you may want to move the Track Clutch Controls back and forth to relieve any “drag” from the Track Clutch Belts].

As the Track is rotated forward, work the forward end of the Track outward. Stop working the Track outward when the Track's Inner Chain is centered between the Inner & Outer Sprockets of the Front Idler...see drawing below.

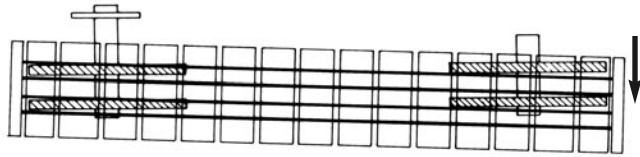

In a similar manner, rotate the Track rearward making sure that the Track's Inner Chain remains between the Inner & Outer Sprockets on the Front Idler. This time work the rearward end of the Track over both the Inner & Outer Sprockets of the Rear Drive...see drawing below.

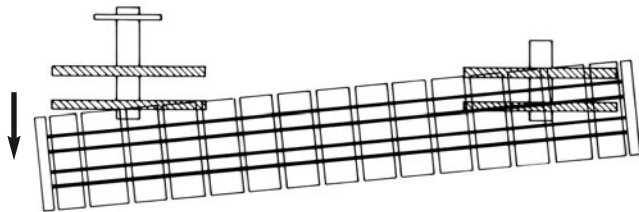

Pulling forward on the Track will allow you to now loop the Track off the remaining Outer Sprocket on the Front Idler allowing complete Track removal.

### TRACK REPLACEMENT

Before replacing a Track, it's wise to thoroughly clean it of all debris...a pressure wash job is a good idea.

Slip the rearward end of Track around the Inner & Outer Sprockets of the Rear Drive engaging the Track's Inner Chain between the Inner & Outer Sprockets of the Rear Drive.

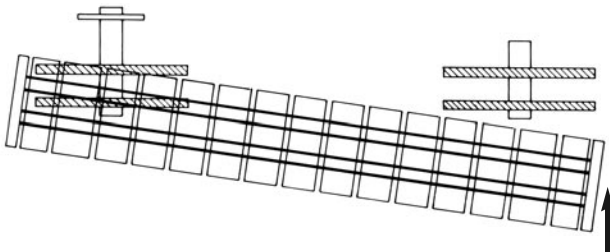

Loop the forward end of the Track around the Inner & Outer Sprockets of Front Idler engaging the Track's Inner Chain between the Inner & Outer Sprockets of the Front Idler.

The Track's Inner Chain should now be located between the Inner & Outer Sprockets of the Front Idler and Rear Drive.

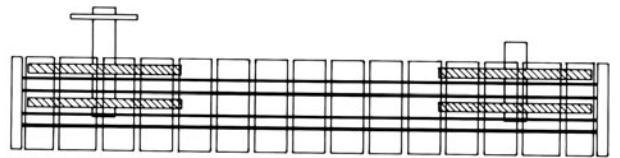

Begin rotating the Track rearward. As the Track rotates rearward work the Track inward until the Track's Inner & Outer Chains align and engage the teeth of their mating Inner & Outer Sprockets of the Rear Drive.

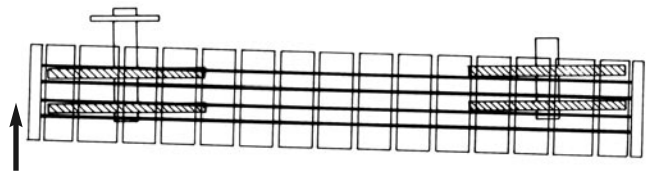

Rotate Track forward and work the Track inward until the Track's Inner & Outer Chains align and engage the teeth of their mating Inner & Outer Sprockets on the Front Idler.

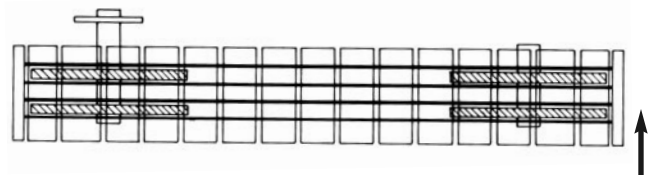

## TRACK TENSIONING

Over protruding “threaded end” of each #1810 Tension Bolt (on each side of Crawler body) slip on, in the following order: five 1/2” Washers, #1689 Washer, #1885 Tube, #1806 Spring, and one #1689 Washer. Secure with Locknut.

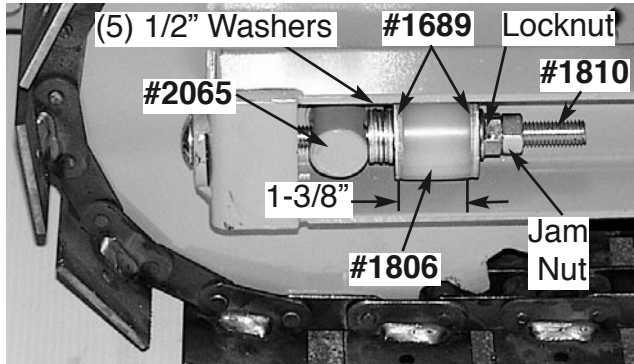

By rotating clockwise the Locknut you mounted to end of each #1810 Tension Bolt, draw the Locknut and associated #1689 Washer (on each Tension Bolt’s end) against its respective #1806 Spring such that each Spring is compressed to a total length of 1-3/8” (measured from inside Washer to Washer).

**NOTE:** Tighten the pair of #1806 Springs 1/4” at a time. Tighten the left Spring 1/4”, then stop and go to the right Spring and tighten it 1/4”. Work back and forth from left side #1806 Spring to right side #1806 Spring, 1/4” at a time, until each Spring is 1-3/8” in total length. [Measure Spring length only...**do not** include the # 1689 Washers in your measurement].

Using a “blunt-nose punch” and hammer, push the #1611 Front Axle Plate (located on both sides of Crawler Body) rearward till it hits a solid stop (approximately 3/16”). **NOTE:** In the work accomplished in steps above, this Plate may have already moved rearward. To check, push Plate forward from the rear, then push it back the required 3/16” distance.

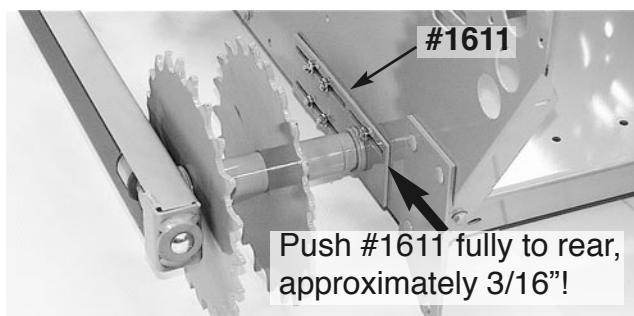

**NOTE: This is a simple adjustment, but it’s proper execution results in extremely stable Track performance in the future!**

At this time, slowly and safely remove all support blocking from underneath your Crawler so that it rests firmly on only its Tracks.

Remount and safely restart your Crawler. Drive it approximately 25 feet forward and then go in reverse, back to your starting point. Shut off the engine, set Parking Brake and dismount. Check the overall length of your #1806 Springs for any changes in length. Readjust to proper 1-3/8” overall length if necessary.

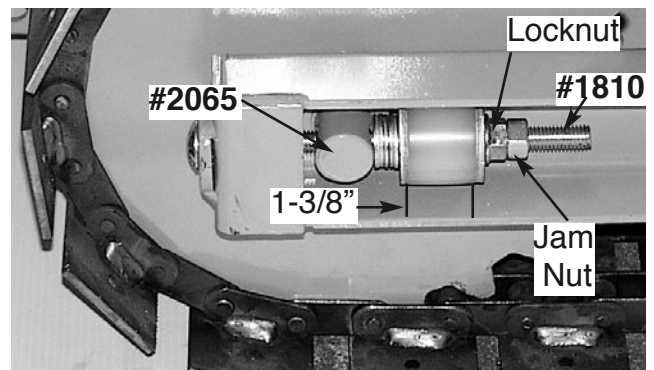

When satisfied, mount a Jam Nut to remaining ends of each #1810 Tension Bolt. Hold each Locknut with a “thin profile” 3/4” open end wrench, and tighten each Jam Nut with a 3/4” box wrench ...tighten securely!

Tighten the five nuts securing Left & Right #1611 Front Axle Plates... check Photo at lower left.



## MAINTENANCE TRACK TENSIONING

Begin by checking the overall length of the #1806 Spring on each side of Crawler. Both Springs should be compressed to an overall length of 1-3/8". [The length measured is only the Spring; **do not** include the #1689 Washers in your measurement!]

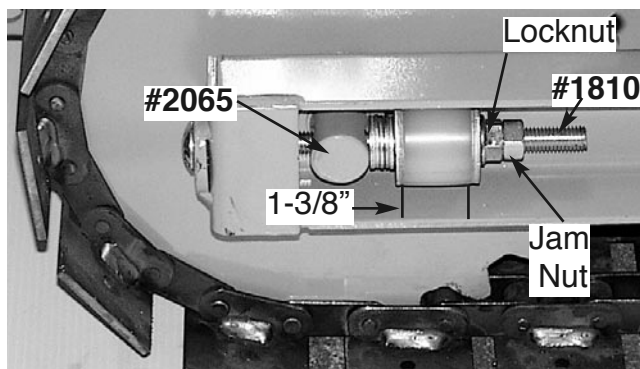

If your Springs have lost this 1-3/8" dimension, or you have just replaced a #1806 Spring or broken #1810 Tension Bolt, follow this procedure:

From "outside" the Crawler's Body, fully loosen (but do not remove) the five nuts on each (Left & Right) #1611 Front Axle Plate.

Remove the Jam Nut on the threaded end of each #1810 Tension Bolt. Rotate (clockwise or counter-clockwise) the Locknut on each #1810 Tension Bolt so that its respective #1689 Washer (next to #1806 Spring) is pushed forward (or released rearward) thereby setting its respective #1806 Spring to a final length of 1-3/8".

[Work back and forth, from left side to right side of Crawler, tightening each Spring 1/4" at a time until you have achieved a 1-3/8" overall length for both Springs. [Measure Spring length only].

Using a "blunt-nose punch" and hammer, push the #1611 Front Axle Plate (located on both sides of Crawler Body) rearward till it hits a solid stop (approximately 3/16"). **NOTE:** in the work done in steps above, this Plate may have already moved rearward. To check, push Plate forward from the rear, then push it back the required 3/16" distance. Tighten the five nuts securing left & right #1611 Front Axle Plates.

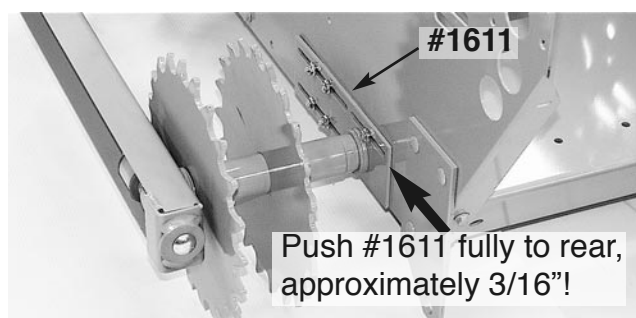

**NOTE:** This is a simple adjustment, but its proper execution results in extremely stable Track performance in the future!

Remount and safely restart your Crawler. Drive it approximately 25 feet forward and then go in reverse, back to your starting point. Shut off the engine, set Parking Brake and dismount. Check the overall length of your #1806 Springs for any changes in length. Readjust to proper 1-3/8" overall length if necessary.

When satisfied, mount a Jam Nut to remaining ends of each #1810 Tension Bolt. Hold each Locknut with a "thin profile" 3/4" open end wrench, and tighten each Jam Nut with a 3/4" box wrench

Tighten the five nuts securing Left & Right #1611 Front Axle Plates

## ENGINE DRIVE CHAIN

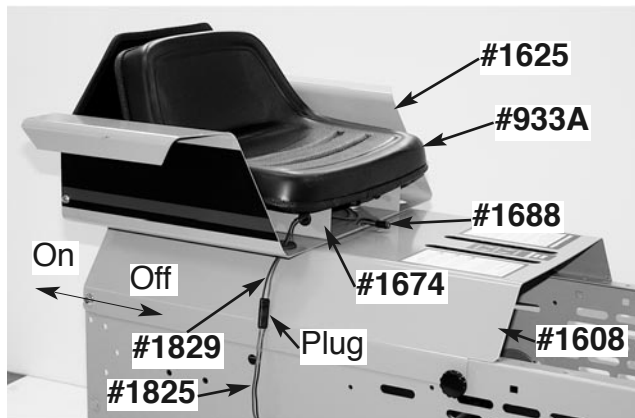

Begin your procedure by parking your Crawler on an open, firm, level surface. Shut off Engine, engage your Parking Brake Lever and dismount.

Raise Hood and rotate it fully forward, remove the #1688 Seat Pin. Then remove the #933A Seat & #1674 Mounting Bracket, #1625 Arm Rests, and #1608 Rear Cover. **NOTE:** Be sure to disconnect the “mating” #1829 and #1825 Seat Wires at their common Plug.

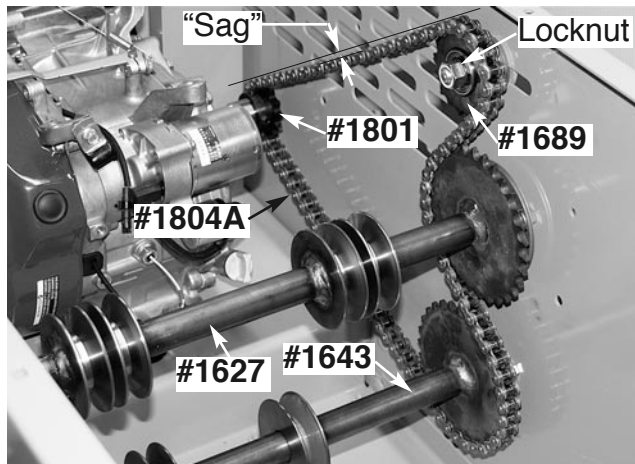

Check your #1804A Engine Drive Chain. Pull up on the recoil starter rope to “tension” the Chain and create slack (sag) in the Chain portion going from #1801 Engine Sprocket to #1689 Idler Sprocket.

This “sag” should be approximately 1/4” to 1/2”. Though quieter operation results from a looser Chain, it does present the rare chance for the Chain to jump off it’s sprockets.

## CHAIN ADJUSTMENT

To **loosen** or **tighten** the Chain, loosen the Locknut securing the #1689 Idler Sprocket and slide the Idler Sprocket assembly **forward** for Chain loosening, and **rearward** for tightening.

**NOTE:** When tightening the Idler in position, hold the Locknut with one wrench, but “tighten” it with a second wrench on the bolt’s head outside the Crawler’s Body...this technique helps to keep the Idler Assembly from “creeping out of position” as you “securely” tighten it’s bolt.

## CHAIN REPLACEMENT

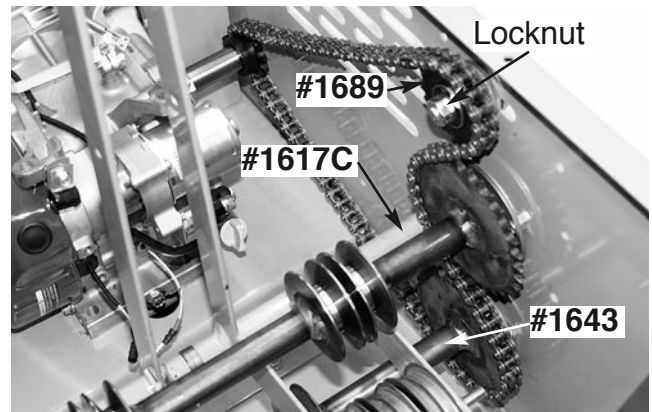

Loosen the Locknut securing the #1689 Idler Sprocket and slide this assembly forward. “Work” the now loose Chain around so the Connector Link is convenient to work on. Remove the Chain Connector Clip and remove the Connector from the Chain. Remove the Chain.

The new Chain is shipped from the factory assembled...the Connector is already attached and the Chain is a continuous loop. You have two ways to install it:

1) You may install it much the same way a Belt is installed...through the “slot” in left end of #1643 Lower Power Shaft. You also need to pass it around the right end of #1617C tube of the #1617R Right Control Handle Assembly.

2) Alternately you can disassemble the Chain’s Connector Link and open the Chain and loop it around it’s various sprockets. Then join the Chain’s ends with it’s Connector Link and secure with Connector Clip.

The easiest is Step (2) above. It’s a little tricky because you have to compress “O” rings while you put on its “flat spring” Connector Clip. Practice with the Chain you took off; it will give you a chance to practice and build confidence.

## SEAT & REAR COVER ASSEMBLY

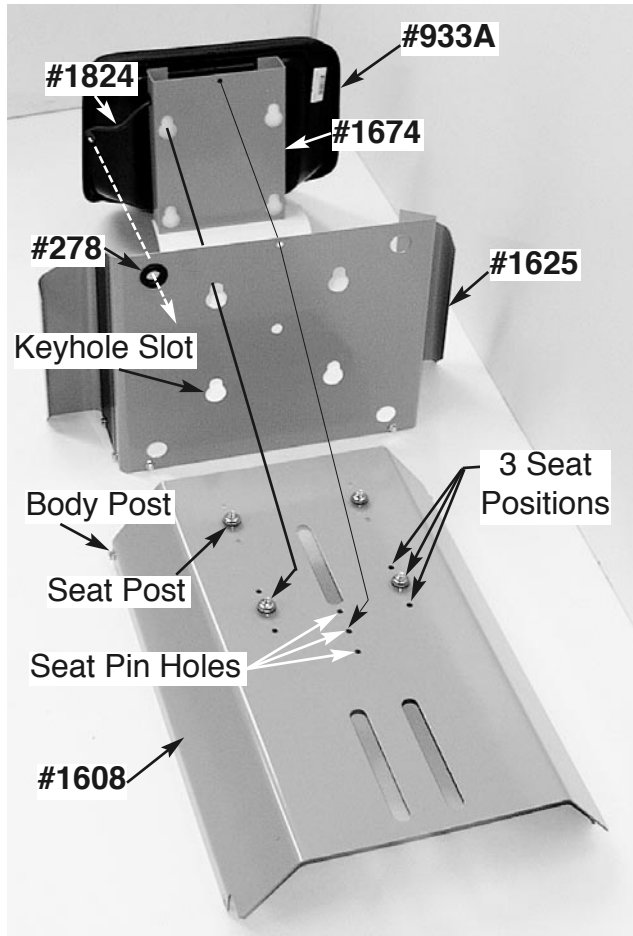

Your Seat & Rear Cover Assembly is made up of three main components: The #1674 Mounting Bracket (with attached #933A Seat) and #1625 Arm Rests mounted to #1608 Rear Cover. They are held together with four “keyhole slots” over four “posts”. The “posts” can be located in three different positions to satisfy the operator’s “seating comfort”.

When all components are nested together they will share a common “seat pin hole” that will lock the assembly together with a #1688 Seat Pin.

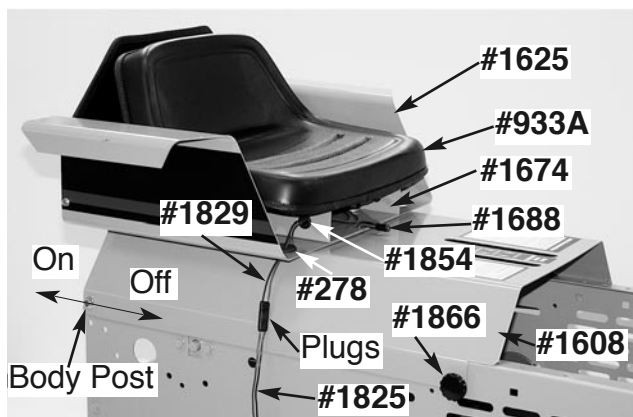

There are **two methods** to remove the Seat Assembly. One is by removing the Assembly as a complete unit (It weighs about 45 lbs.). The second method takes longer but allows you to disassemble the unit into three components that weigh about 15 lbs. each. Both methods are explained below...the choice is yours.

### METHOD 1 - Seat Removal

Fully open the Hood by loosening a few turns of the two #1866 “threaded” Knobs (located at lower rear of Hood) and then rotating fully forward. Disconnect the #1824 & 1825 Wires at their mating Plug. Remove the two #1866 “threaded” Knobs at lower front edge of #1608 Rear Cover. Slide the complete Seat Assembly rearward and remove.

#### Seat Assembly:

To replace your Seat Assembly “reverse” the steps above.

- 1) Upon completion of reassembly, **make sure** that #1824 Wire & Plug pass through #1854 & #278 Grommets and connects to mating #1825 Wire & Plug.
- 2) Make sure “front top edge” of #1608 Cover rests on top of “lip” that protrudes rearward out of lower section of #1618 Dash.
- 3) Close Hood and secure it and Cover Assembly with #1866 Knobs.

### METHOD 2 - Seat Removal

Fully open the Hood by loosening a few turns the two #1866 “threaded” Knobs (located at lower rear of Hood). Rotate Hood fully forward until Chain holds it. Disconnect the #1824 & 1825 Wires at mating Plug. Draw #1824 Wire & Plug out of #278 Grommet. Remove #1688 Seat Pin and slide “forward” the #1674 Mounting Bracket with #933A Seat and lift up to remove. Take #1625 Arm Rests, slide forward and lift up to remove. Remove the two #1866 “threaded” Knobs on front lower edges of #1608 Cover. Slide the Cover rearward and remove.

#### Seat Assembly:

To replace your Seat Assembly “reverse” the steps above.

- 1) Upon completion of reassembly, **make sure** that #1824 Wire & Plug pass through #1854 & #278 Grommets and connect to mating #1825 Wire & Plug.
- 2) Make sure “front top edge” of #1608 Cover rests on top of “lip” that protrudes rearward out of lower section of #1618 Dash.
- 3) Close Hood and secure it and Cover Assembly with #1866 Knobs.

# TIPS FOR TOP PERFORMANCE

## CLUTCH BELTS

The use of rugged, though uncomplicated Belt Clutches, gives the RS1000 Crawler amazing performance while at the same time keeps its initial purchase price and later maintenance costs within the homeowner's budget.

The life expectancy of these Clutch Belts is the direct result of the type of work being done and the operator's driving technique. It is strongly recommended at this time that you thoroughly read the Track Clutch Belt Removal & Installation chapter in the Service Section of this Manual to give you an over-view of the mechanics of your drive system.

In factory tests of different driving techniques, it has been found that Belt life will range from 25 to 200 hours. This testing proved that the operator is the greatest variable in determining Belt life. From these tests, the following driving rules have evolved. If followed, they will give you the best Belt life consistent with the severity of work you are doing.

1. Do not "jam-on" your Clutch Controls ...rather operate them smoothly and work into your load. If your Crawler can not push a particular load you have two options: immediately reduce the load (raise the Bucket or Blade) or backup and take a new angle at the load...never hold your track controls in a fixed position (forward or rearward) against an immovable object, you will unnecessarily wear the Belts.

- 2 Your Crawler has outstanding pushing ability, but its up to you, the operator, to use its ability in the most efficient and economical manner.

3. When you want to go slowly for a sustained period, reduce your engine speed...do not "slip" your Belt Clutches for long periods of time! Your Belt Clutches are no different than the disk clutch found in a large truck...if you constantly slip the Clutch under heavy loads you will burn the clutch faces and decrease clutch life. It's no different with your Belt Clutches.

4. Reserve horsepower has been designed into your Crawler. This means you can reach the maximum torque necessary to fully drive your Crawler tracks with your engine operating at only about half-speed.

## TRACKS

The track system of your RS1000 Magnatrac Crawler is the result of over 40 years of compact crawler experience. The track system is of an “un-guided” design, but is extremely stable due to its double track chain design. A few rules are listed below that if followed will give you maximum Track performance.

1. Avoid overloading your track system with the material you are working in. Always work in loose materials by clearing a “driving path” with the attachment (Blade, Bucket, etc.) you are using. This technique will allow a minimum of material to enter the track system.
2. Avoid climbing on a pile of loose material and counter-rotating your tracks. This action will “cork-screw” the Tracks into the pile and force unnecessarily large amounts of material into the Tracks. The track system is designed to absorb a great deal of material, but the less you force it to “digest”, the greater will be the Track’s stability and overall life.
3. Periodically, following the Track Tensioning instructions in your Operator’s/Technical Manual, check your Track tension by checking the length of the #1806 Spring.

Though this Spring adjustment is not a precise type of adjustment, it must be realized that to over-tension the Spring will cause a higher level of wear in your track bearings, while under-tensioning will cause potential derailing of your Track.

As always, the Struck Corporation through the customer service department, stands ready to help you with any technical or work related questions you may have either now or in the future! Call (262) 377-3300 or Fax (262) 377- 9247.

# WIRING DIAGRAM GX390 HONDA Engine with *ELECTRIC* Start

